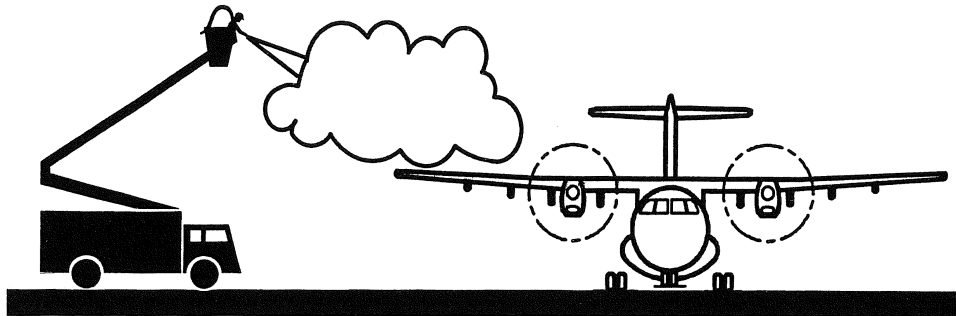


AIRCRAFT FULL-SCALE TEST PROGRAM FOR THE 1996/97 WINTER



Prepared for

Transportation Development Centre

on behalf of

Civil Aviation

Safety and Security

Transport Canada

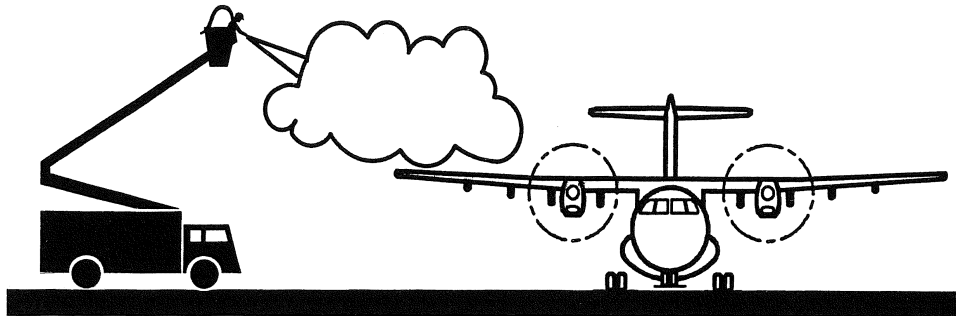
by

APS AVIATION INC. **APS**

December 1997

*This report was first signed and provided to Transport Canada as Final Version 1.1 in September 1998.
It has been republished as Final Version 1.2 in August 2025 to improve the quality of the graphics.*

AIRCRAFT FULL-SCALE TEST PROGRAM FOR THE 1996/97 WINTER



by

John D'Avirro
Michael Chaput,
Peter Dawson,
Medhat Hanna, and
Steve Fleming.

APS AVIATION INC. **APS**

December 1997

*This report was first signed and provided to Transport Canada as Final Version 1.1 in September 1998.
It has been republished as Final Version 1.2 in August 2025 to improve the quality of the graphics.*

The contents of this report reflect the views of APS Aviation Inc. and not necessarily the official view or opinions of the Transportation Development Centre of Transport Canada.

The Transportation Development Centre does not endorse products or manufacturers. Trade or manufacturers' names appear in this report only because they are essential to its objectives.

DOCUMENT ORIGIN AND APPROVAL RECORD

Prepared by: John D'Avirro, Michael Chaput, Peter Dawson, Medhat Hanna, and Steve Fleming.

Reviewed by: Alfucchesi - APS September 3, 1998
for: Gilles Bourret, Eng. Date
Director of Programs

Approved by: Alfucchesi - APS September 3, 1998
for: R.V. Potter, Ph.D. Date
Vice-President Programs & QA

ACKNOWLEDGEMENTS

The authors gratefully acknowledge the contribution of the data collection and research team: Joe Argento, Dominique Banoun, Elvis Batur, Alain Bisson, Nicolas Blais, John Bourada, Maher Hanna, Bishoy Ishak, Jo-Anne Lecompte, Jeff Mayhew, Anouk Mukherjee, Leslie Nagy, Antoni Peters, Donald Robitaille, Elio Ruggi, and Geddes Thurton.

Special thanks are extended to Frank Eyre and Barry Myers of the Transportation Development Centre for their participation, contribution, and guidance provided in the preparation of this document.

Un sommaire français se trouve avant la table des matières.

PREFACE

At the request of the Transportation Development Centre of Transport Canada, APS Aviation Inc. has undertaken a research program to further advance aircraft ground deicing/anti-icing technology. Specific objectives of the APS test program were:

- To complete the substantiation of holdover time tables and evaluate those parameters that may reduce holdover times for currently available and properly qualified SAE deicing and anti-icing fluids (Type I, Type II, Type III and Type IV);
- To collect weather data on winter storms at airports and to assess the precipitation, wind and temperature values that bound the holdover time ranges given in the tables;
- To develop a procedure for the evaluation of fluid dry-out characteristics and to determine the dry-out characteristics of fluids;
- To determine the influence of fluid type, precipitation and wind on location and time to fluid failure initiation, and failure progression on service aircraft; and
- To review, from an operations standpoint, those factors that contribute to the need for a freeze point buffer and make recommendations for possible revisions.

The research activities of the program conducted on behalf of Transport Canada during the 1996/97 winter season are documented in three separate reports. The titles of these reports are as follows:

- TP 13131E Aircraft Ground De/Anti-icing Fluid Holdover Time Field Testing Program for the 1996/97 Winter;
- TP 13130E Aircraft Full-Scale Test Program for the 1996/97 Winter; and
- TP 13129E Examination of the Role of Fluid Freeze Point Buffers.

This report, TP 13130E, has the following objective:

- To determine the influence of fluid type, precipitation, and wind on location and time to fluid failure initiation, and also failure progression on service aircraft.

This objective was met by conducting trials on operational aircraft during periods of snow or freezing rain. The influence of wind was evaluated by variation of aircraft orientation relative to the wind direction ($\pm 90^\circ$, 180°) once or twice during each test session. On propeller aircraft, in order to evaluate the influence of propeller wash on fluid failure, tests were carried out in which both wings were sprayed but with only one propeller in rotation.

ACKNOWLEDGEMENTS

Research has been funded by the Civil Aviation Group, Transport Canada, with support from the Federal Aviation Administration. This program of research could not have been accomplished without the participation of many organizations. APS would therefore like to thank the Transportation Development Centre, the Federal Aviation Administration, the National Research Council of Canada, Atmospheric Environment Services, Transport Canada, and the fluid manufacturers for their contributions to and assistance with the project. Special thanks are extended to Air Canada, Aéromag 2000, American Airlines, Canadian Airlines International, CanAir Cargo, the Department of National Defence, and Inter-Canadian for provision of personnel and facilities and for their cooperation on the test program. APS would also like to acknowledge the dedication of the research team, whose performance was crucial to the acquisition of hard data leading to the preparation of this document.



1. Transport Canada Publication No. TP 13130E		2. Project No. 9131 (DC 150)		3. Recipient's Catalogue No.	
4. Title and Subtitle Aircraft Full-Scale Test Program for the 1996/97 Winter				5. Publication Date December 1997	
				6. Performing Organization Document No.	
7. Author(s) J. D'Avirro, M. Chaput, P. Dawson, M. Hanna, and S. Fleming				8. Transport Canada File No. ZCD-1455-14	
9. Performing Organization Name and Address APS Aviation Inc. 1100 René-Lévesque Blvd. West, Suite 1340 Montreal, Quebec, H3B 4N4				10. PWGSC File No. XSD-6-01882	
				11. PWGSC or Transport Canada Contract No. T8200-6-6553	
12. Sponsoring Agency Name and Address Transportation Development Centre (TDC) 800 René Lévesque Blvd. West, 6th Floor Montreal, Quebec, H3B 1X9				13. Type of Publication and Period Covered Final	
				14. Project Officer Barry B. Myers	
15. Supplementary Notes (Funding programs, titles of related publications, etc.) Research reports produced on behalf of Transport Canada for testing during previous winters are available from the Transportation Development Centre (TDC). Three reports (including this one) were produced as part of this winter's research program. Their subject matter is outlined in the preface.					
16. Abstract <p>The primary objectives of this study were to determine the influence of several variables on the progression of anti-icing fluid failure on aircraft wings under conditions of freezing precipitation, to assess the validity of current aircraft representative surfaces, and to determine potential locations for sensor placement on aircraft wings. Secondary objectives included determination of fluid thickness distribution on turboprop and turbofan aircraft and examination of fluid application techniques.</p> <p>Simultaneous trials were conducted on standard flat plates and on aircraft in natural precipitation. Both Type I and Type IV fluids were employed. A total of 40 full-scale fluid failure tests and 23 fluid thickness tests were conducted.</p> <p>Results show that the progression of failure on a wing is affected by aircraft type and wind direction. Downwind wings in crosswind conditions were found to fail more rapidly than upwind wings. Other factors, such as precipitation rate, precipitation type, and temperature, were found to influence the speed at which failures occur.</p> <p>The wing representative surface is aircraft specific and should be positioned in an area where early failures consistently occur. For both the Boeing 737 and McDonnell Douglas DC 9 tested, the representative surface locations were inappropriate. For the Fokker 100 tested, the current position is valid.</p> <p>Early fluid failure criteria may be used for determining point detection sensor locations. In this case, sensors should be placed where early failures consistently occur. If this is not possible, an algorithm would have to be developed to predict the wing conditions, based on the condition of the fluid over the sensor head. Other criteria might dictate more suitable locations for sensor placement.</p> <p>Results of the full-scale tests using Type I and Type IV fluids confirm that flat plate holdover times are consistent with the time it takes for failure to progress to 10 percent of the entire wing's surface area.</p> <p>Fluid thickness results confirm earlier findings, which showed that film profiles are thinnest on the leading and trailing edges and thickest on the wing midsection. Results from fluid application trials show that application quality is sensitive to spray techniques.</p>					
17. Key Words Aircraft, snow, drizzle, rain, anti-icing, fluid, holdover, test, precipitation, wing, plate, deicing, ice, sensor, temperature, thickness.			18. Distribution Statement Limited number of copies available from the Transportation Development Centre		
19. Security Classification (of this publication) Unclassified		20. Security Classification (of this page) Unclassified		21. Declassification (date) —	22. No. of Pages xxviii, 172 apps
					23. Price —



1. No de la publication de Transports Canada TP 13130E		2. No de l'étude 9131 (DC 150)		3. No de catalogue du destinataire	
4. Titre et sous-titre Aircraft Full-Scale Test Program for the 1996/97 Winter				5. Date de la publication Décembre 1997	
				6. No de document de l'organisme exécutant	
7. Auteur(s) J. D'Avirro, M. Chaput, P. Dawson, M. Hanna et S. Fleming				8. No de dossier - Transports Canada ZCD-1455-14	
9. Nom et adresse de l'organisme exécutant APS Aviation Inc. 1100 boul. René-Lévesque Ouest, Bureau 1340 Montréal (Québec) H3B 4N4				10. No de dossier - TPSGC XSD-6-01882	
				11. No de contrat - TPSGC ou Transports Canada T8200-6-6553	
12. Nom et adresse de l'organisme parrain Centre de développement des transports (CDT) 800, boul. René Lévesque Ouest, 6^e étage Montréal (Québec) H3B 1X9				13. Genre de publication et période visée Final	
				14. Agent de projet Barry B. Myers	
15. Remarques additionnelles (programmes de financement, titres de publications connexes, etc.) Les rapports sur les recherches effectuées au cours des hivers précédents pour le compte de Transports Canada sont disponibles au Centre de développement des transports (CDT). Trois rapports, dont le présent, ont été produits dans le cadre des recherches menées pendant l'hiver 1996-1997. Leur objet est précisé dans l'avant-propos.					
16. Résumé <p>Le but premier de cette recherche était de cerner l'influence de plusieurs variables sur la progression de la perte d'efficacité des liquides dégivrants et antigivrage sur les ailes d'un avion dans des conditions de précipitation verglaçante, d'évaluer la validité des surfaces représentatives actuellement utilisées pour juger de l'état de givrage général des avions et de déterminer sur les ailes les endroits où il serait indiqué de placer des capteurs. Parmi les objectifs secondaires fixés à la recherche figuraient la détermination de la répartition des épaisseurs de liquide sur les avions à turbopropulseurs et à turbosoufflante et l'examen des techniques d'application des liquides antigivrage et dégivrants.</p> <p>Les chercheurs ont mené simultanément des essais sur plaques planes standard et sur ailes d'avions, sous précipitations naturelles. Ils ont utilisé des liquides de type I et de type IV pour un total de 40 essais visant à mesurer la perte d'efficacité et de 23 visant à déterminer la répartition des épaisseurs de liquide.</p> <p>Les résultats indiquent que la progression de la perte d'efficacité des liquides sur une aile d'avion dépend du type de l'avion et de la direction du vent. Les ailes sous le vent par vent traversier se givrent plus rapidement que les ailes en amont. D'autres facteurs tels que l'intensité de la précipitation, le type de précipitation et la température, influenceraient la vitesse de perte d'efficacité des liquides antigivrage et dégivrants.</p> <p>La surface représentative d'une aile est différente d'un avion à l'autre et devrait se trouver dans la zone où s'amorce régulièrement la perte d'efficacité. Sur le Boeing 737 et le DC-9 de McDonnell Douglas utilisés pour les essais, la position de la surface représentative était inappropriée. Dans le cas du Fokker 100, la position actuelle de cette surface est appropriée.</p> <p>On peut se fier au critère de perte d'efficacité initiale pour déterminer l'emplacement des capteurs ponctuels. Les capteurs doivent alors être placés là où surviennent régulièrement les premières pertes d'efficacité. Dans les cas où il est impossible de placer les capteurs dans ces zones, un algorithme devrait être élaboré pour prévoir l'état de givrage de l'aile en fonction de l'état du liquide antigivrage/dégivrant au-dessus du capteur. D'autres critères pourraient indiquer des emplacements plus appropriés pour l'implantation des capteurs.</p> <p>Les essais sur voilures concernant les liquides de type I et IV montrent que les durées d'efficacité sur plaques planes sont représentatives du temps qui s'écoule jusqu'à une perte d'efficacité touchant 10 p. 100 de la superficie totale des ailes.</p> <p>Les résultats concernant la répartition des épaisseurs de liquide confirment les constatations antérieures, soit que l'on trouve les pellicules de liquide les plus minces sur les bords d'attaque et de fuite et les pellicules les plus épaisses, au centre de l'aile. Les essais touchant l'application des liquides montrent que la qualité de la protection obtenue dépend de la technique d'arrosage retenue.</p>					
17. Mots clés Avion, neige, bruine, pluie, antigivrage, agent, durée, d'efficacité, test, précipitation, aile, plaque, dégivrage, glace, capteur, température, épaisseur			18. Diffusion Le Centre de développement des transports dispose d'un nombre limité d'exemplaires		
19. Classification de sécurité (de cette publication) Non classifiée		20. Classification de sécurité (de cette page) Non classifiée		21. Déclassification (date) —	22. Nombre de pages xxviii, 172 ann.
					23. Prix —

EXECUTIVE SUMMARY

At the request of the Transportation Development Centre, APS Aviation Inc. undertook a research program to further advance aircraft ground deicing/anti-icing technology. The primary objective of the project was to determine the influence of fluid type, precipitation, and wind on the location and time to fluid failure initiation, and on failure progression on service aircraft.

Other specifically addressed objectives were:

- To generate data that could be used to assist pilots with visual identification of fluid failure;
- To assess, for selected aircraft, a pilot's field of view during adverse conditions of winter precipitation;
- To assess whether representative surfaces can be used to provide a reliable first indication of anti-icing fluid failure;
- To explore the potential application of point detection sensors to warn the pilot-in-command of conditions that are unsafe for take-off;
- To obtain failed fluid contamination distributions and profiles for use as inputs to a theoretical program to assess the effects of such contamination on possible aircraft take-off performance; and
- To compare the performance of de/anti-icing fluids on aircraft surfaces with the performance of de/anti-icing fluids on flat plates.

A secondary objective was to determine the distribution of fluid thickness on the wing surface as the fluid layer stabilized over time and to examine the impact of propeller wash on the fluid layer.

A supplemental objective, established during the test season, was to document the influence of different spray techniques and different spray nozzles on the resultant fluid layer on the aircraft wing.

Description and Processing of Data

A set of trials was designed involving simultaneous application of Type I and Type IV fluids on standard flat plates and aircraft wings in natural precipitation conditions. Standard flat plate test procedures, as used in holdover time trials, were followed, and the aircraft were tested in a static position. A total of 40 full-scale fluid failure tests were conducted on nine different occasions, including a dry run. Of this total, 33 provided useable data.

Simultaneous aircraft and flat plate tests, as well as fluid film thickness profile measurements, were conducted at Dorval International Airport in Montreal, using Canadian Airlines International Boeing 737, Inter-Canadian ATR 42, and American Airlines Fokker 100 aircraft. Further thickness trials were performed in Winnipeg and at Mirabel Airport, Montreal, using Department of National Defence de Havilland Dash 8 and CanAir Cargo Boeing 737 equipment respectively.

The Type I and Type IV fluids used in the aircraft fluid failure trials were provided by Union Carbide. Only fluids produced by Union Carbide were tested, because these were the fluids available in American Airlines, Canadian Airlines International, and Inter-Canadian de/anti-icing vehicles. Type I ADF was applied in its standard concentration (XL54) and Type IV Ultra+ was applied in its neat concentration.

Results and Conclusions

Progression of Failure

Observations of fluid failure tests on aircraft wings indicate that several factors directly affect the progression of failure.

- Aircraft type and, more particularly, wing design were shown to affect the progression of failure. Flight control systems, such as ailerons, flaps, slats, and spoilers, are well-defined sections of aircraft wings, and present discontinuities upon which failures initiate and spread. The leading and trailing edges appear to be the most failure-sensitive areas, because of the presence of control surfaces and surface discontinuities.

For aircraft with a hard wing design, such as the Fokker 100, initial failures occurred primarily on the ailerons and spoilers of the trailing edge, because no discontinuities are present on the leading edge to disrupt the fluid flow. For aircraft with slatted wings, such as the Boeing 737 and McDonnell Douglas DC-9, failures initiated and progressed on both the leading and trailing edges, because of the discontinuities caused by the control surfaces in these sections. Tests of progression of failure conducted on the ATR 42 were inconclusive.

- The effect of wind direction on the progression of failure was observed. In crosswind conditions, the downwind wing always fails prior to the upwind wing. The actual patterns of failure were similar for a Fokker 100 but differed for a Boeing 737. In tailwind conditions, first wing failure occurs on the trailing edge, while in headwind conditions, leading edge failure is always present at the time of first failure.
- Several variables, such as temperature, precipitation type, rate of precipitation, and fluid type, were found to have insignificant effects on the progression of failure. These same variables do, however, affect the time to first failure, and rate of failure progression.

Validity of the Representative Surface

The wing representative surface is aircraft specific, and should be positioned in an area where early failures consistently occur. For the Boeing 737 and McDonnell Douglas DC-9 tested, the representative surface locations were inappropriate. For the Fokker 100 tested, the current position is valid, provided that the visibility from the cabin is unobstructed by the flap fairing. Since failures initiate on the leading and trailing edges, inclusion of these surfaces as part of the representative surface should also be considered.

Sensor Placement

In cases where point detection sensors cannot be located at the point of first failure, an algorithm would have to be developed to predict the conditions of the wing, based on the condition of the fluid over the sensor head.

Holdover Time Correspondence

Results of the full-scale tests with Type I fluid confirm that flat plate holdover times are approximately equivalent to the time it takes for fluid failure to progress to 10% of the entire wing's surface area. In tests using Type IV fluids, when the fluid application is uniform and in accordance with fluid manufacturer's guidelines, the same correlation is observed between flat plate and wing surface failures.

Appearance of Fluid Failure

The appearance of fluid failure was found to be influenced by the physical test conditions. Visual detection or identification of fluid failures in freezing drizzle and light freezing rain can be difficult, as the appearance of the failure condition seems to vary with temperature. Type I and Type IV failures in natural snow tests on aircraft wings were also shown to be different.

Evaluation of Roughness

A method was developed to measure the roughness profile of fluid undergoing failure at different times during the failure process. This method could be used in the development of future surface roughness models.

Fluid Thickness Tests

Fluid thickness tests were conducted during periods of no precipitation to determine the distribution of fluid thickness on the wing surface as the fluid layer stabilized over time. Results of thickness measurements on the Boeing 737 aircraft were similar to results from trials carried out on other jet aircraft in the previous year's test program. Thickness trials on other fluid brands and on other specific aircraft are yet to be performed.

Special tests were conducted on propeller aircraft to assess the impact of propeller wash on the thickness of the applied fluid layer. Test results indicated where on the wing and to what extent the fluid thickness was influenced.

During tests with one operator, it was discovered that the wing surfaces had been treated with an ice-phobic material that caused the deicing fluid to quickly run off the wing. As this type of material is available for general use, its interaction with deicing and anti-icing fluids must be investigated to determine the overall effects on wing protection.

Fluid Application Trials

Over the past several years, a number of airline operators have been included in APS's full-scale aircraft tests. These tests showed that certain factors are subject to variation. They include fluid application techniques, skill of the applicator, and fluid application equipment. Their influence on the fluid films produced are related to the quality of the fluid application on a given aircraft surface, particularly with respect to uniformity of surface coverage and quantity of fluid applied.

Special trials were conducted to examine and document the influence of different spray techniques and different spray nozzles on the resultant fluid layer on the aircraft wing. Photographic and video documentation of the tests and the results was developed into a video that has been presented at several national and international meetings. Viewer response has been strong and copies have been provided to a number of carriers, ground handlers, and fluid and equipment manufacturers for incorporation into their training programs.

Documentation of Wing Areas Visible to Flight Crew

Pre-take-off checks by the flight crew from inside the aircraft have some natural limitations, including, for some aircraft, a restricted view of the wing surface. A special activity was conducted to document, through a series of photographs, the area of the wing that is visible from the inside of several aircraft. Use of ordinary field binoculars was found to provide a much enhanced view of details on the wing surface.

Documentation of the appearance of wings in typical operational lighting conditions and during snow or freezing precipitation would help to clarify this subject.

Recommendations

Recommendations are made to extend full-scale fluid failure tests to commuter aircraft – the Canadair Regional Jet and to high-wing turboprop aircraft, as well as to advance the research related to the operational use of wing sensors and remote ice detection sensors. Improvements to procedures are also recommended.

This page intentionally left blank.

SOMMAIRE

À la demande du Centre de développement des transports, APS Aviation Inc. a lancé un programme de recherche visant à développer la technologie de dégivrage/antigivrage des avions au sol. L'objectif premier de la recherche était de déterminer l'influence de différents facteurs – type de liquide utilisé, type de précipitation et vent – sur l'endroit où s'amorce la perte d'efficacité, le délai d'apparition de la perte d'efficacité initiale et la vitesse de progression de la perte d'efficacité sur un avion en service.

La recherche visait aussi les objectifs suivants :

- Produire des données susceptibles d'aider les pilotes à repérer les signes de perte d'efficacité des agents antigivrage/dégivrants;
- Évaluer le champ de vision du pilote d'un avion donné dans des conditions défavorables de précipitations hivernales;
- Déterminer le bien-fondé de l'observation de surfaces représentatives comme technique de détection fiable des premiers signes de perte d'efficacité d'un agent antigivrage;
- Valider l'utilisation de capteurs ponctuels comme outil d'aide à la décision pour les pilotes appelés à décoller sous précipitations givrantes;
- Déterminer la répartition et le profil des surfaces couvertes de liquide ayant perdu son efficacité pour alimenter un programme d'études théoriques visant à évaluer les effets de la contamination résultante sur la performance au décollage des avions;
- Comparer la durée d'efficacité des liquides antigivrage et dégivrants sur les ailes d'avions à celle sur plaques planes.

La recherche avait pour objectif secondaire de déterminer la répartition des épaisseurs de liquide sur une aile à mesure que la couche de liquide se stabilisait dans le temps et d'examiner l'effet du souffle d'hélice sur cette couche.

Un objectif additionnel a été défini en cours de campagne d'essais : déterminer la qualité de la couche protectrice obtenue, selon la technique d'arrosage utilisée et avec différents types de lances d'arrosage.

Description des essais et traitement des données

Une série d'essais comportait l'application simultanée de liquides de type I et de type IV sur plaques planes standard et sur ailes d'avions, sous précipitation naturelle. Les chercheurs ont appliqué le mode opératoire des tests de détermination des durées

d'efficacité sur plaques planes standard et fait les mesures et observations sur les avions à poste fixe. Au total, 40 essais de détermination de la durée d'efficacité ont été réalisés en neuf fois, y compris une pratique générale des modes opératoires. De ces essais, 33 ont livré des données exploitables.

Les essais simultanés sur avions (Boeing 737 des Lignes aériennes Canadien international, ATR 42 d'Inter-Canadien et Fokker 100 d'American Airlines) et sur plaques planes, ainsi que la détermination des profils de distribution des épaisseurs de liquide, ont été réalisés à l'aéroport international de Montréal, Dorval. D'autres essais de détermination des profils d'épaisseur ont été effectués à Winnipeg et à l'aéroport international de Montréal, Mirabel, sur des Dash 8 de Havilland de la Défense nationale et des Boeing 737 tout cargo de CanAir, respectivement.

Les liquides de types I et IV appliqués lors des essais concernant la perte d'efficacité provenaient de la société Union Carbide. Seuls les produits de cette société ont été testés, puisque les sociétés American Airlines, Lignes aériennes Canadien international et Inter-Canadien s'approvisionnaient toutes auprès d'Union Carbide. Le liquide ADF de type I a été appliqué en concentration standard (XL54), tandis que le liquide Ultra+ de type IV l'a été non dilué.

Résultats et conclusions

Progression de la perte d'efficacité

Les observations faites sur les ailes d'avions révèlent que plusieurs facteurs influent directement sur la vitesse de progression de la perte d'efficacité.

- Le type d'avion et, plus particulièrement, sa voilure ont un effet déterminant sur la progression de la perte d'efficacité. Les commandes de vol, telles que les ailerons, les volets, les bords de bord d'attaque et les déporteurs, constituent des sections bien définies de la voilure et présentent des solutions de continuité propices à l'amorce et à la progression de la perte d'efficacité. Les bords d'attaque et de fuite semblent être les endroits les plus à risque en raison des surfaces manoeuvrables et des discontinuités qui s'y trouvent.

Sur les avions à voilure sans bec d'attaque, tels que le Fokker 100, la perte d'efficacité survient initialement surtout sur les ailerons et les déporteurs parce qu'il n'y a pas de solution de continuité sur le bord d'attaque susceptible de perturber l'écoulement. Sur les avions à bec de bord d'attaque (Boeing 737 et DC-9 de McDonnell Douglas, par exemple), la perte d'efficacité s'amorce et s'étend à la fois sur les bords d'attaque et les bords de fuite qui présentent tous deux des discontinuités aux limites des surfaces manoeuvrables qu'ils comportent. Les essais réalisés sur les ATR 42 n'ont pas donné de résultats probants.

- Il a été noté que la direction du vent a un effet sur la progression de la perte d'efficacité. Par vents traversiers, l'aile sous le vent givre toujours plus rapidement que l'aile en amont. L'évolution de la perte d'efficacité a été similaire sur les deux ailes des Fokker 100, mais différente sur les Boeing 737. Par vent arrière, la perte d'efficacité touche en premier lieu le bord de fuite, tandis que par vent debout, le bord d'attaque présente toujours des signes de perte d'efficacité en premier ou, à tout le moins, en même temps que le bord de fuite.
- Plusieurs variables – température, type de précipitation, intensité de la précipitation, type de liquide utilisé – n'ont qu'un effet négligeable sur la progression de la perte d'efficacité. Par contre, elles ont un effet déterminant sur le délai d'apparition de la perte d'efficacité initiale et sur la vitesse de progression de la perte d'efficacité.

Validité des surfaces représentatives

La surface représentative d'une aile est différente d'un avion à l'autre et devrait se trouver dans la zone où s'amorce régulièrement la perte d'efficacité. Sur les Boeing 737 et les DC-9 de McDonnell Douglas testés, les positions de la surface représentative étaient inadéquates. La position actuelle de cette surface est appropriée sur les Fokker 100 dans la mesure où la vue depuis la cabine de pilotage n'est pas obstruée par les carénages de volet. Comme les pertes d'efficacité apparaissent d'abord sur les bords d'attaque et de fuite, l'inclusion de ces zones dans les surfaces représentatives devrait être envisagée.

Emplacement des capteurs

Dans les cas où il est impossible de placer les capteurs ponctuels dans la zone de perte d'efficacité initiale, un algorithme devrait être élaboré pour prévoir les états de givrage de l'aile en fonction de l'état du liquide antigivrage/dégivrants au-dessus du capteur.

Correspondance des durées d'efficacité

Les résultats des essais sur voilure du liquide de type I confirment que les durées d'efficacité établies sur plaques planes correspondent approximativement au temps que la perte d'efficacité met à s'étendre à 10 p. 100 de la superficie totale de la voilure. La même corrélation a été notée dans le cas des liquides de type IV appliqués uniformément et selon les instructions du fabricant.

Aspect du liquide ayant perdu son efficacité

L'aspect du liquide ayant perdu son efficacité varie selon les conditions météorologiques. Il peut être difficile de détecter ou de repérer les zones de perte d'efficacité sous bruine ou pluie légère verglaçantes, l'aspect des zones en question pouvant varier avec la température. On a également noté une différence d'aspect des liquides de type I et IV ayant perdu leur efficacité sous précipitation neigeuse naturelle.

Évaluation de la rugosité

Les chercheurs ont mis au point une méthode de mesurage de la rugosité des zones de perte d'efficacité à différents stades de progression de la perte d'efficacité. Cette méthode pourrait servir de point de départ à l'élaboration d'éventuels modèles de prévision rugosimétrique.

Détermination du profil des épaisseurs de liquide

Ces essais ont été menés en l'absence de précipitation afin de déterminer la répartition des épaisseurs de liquide sur une voilure à mesure que la couche liquide se stabilisait dans le temps. Les résultats des essais sur Boeing 737 se rapprochaient de ceux des essais réalisés sur d'autres avions à réaction, l'année d'avant. Il reste à effectuer des essais avec d'autres marques de liquide et sur d'autres types précis d'avion.

Des essais spéciaux sur avions à hélices ont permis de déterminer l'effet du souffle d'hélice sur l'épaisseur de la couche de liquide appliquée. On sait maintenant où sur l'aile et dans quelle mesure l'épaisseur a été modifiée.

Aux essais réalisés sur les avions d'un des transporteurs participants, on s'est aperçu que la surface des ailes avait été revêtue d'un produit empêchant l'adhésion des précipitations givrantes, qui avait pour effet d'accélérer le ruissellement au sol du liquide dégivrant appliqué. Comme il s'agit d'un produit d'emploi général, il est impératif d'en vérifier les interactions avec les liquides antigivrage et dégivrants afin de cerner son incidence sur la protection des ailes en général.

Examen des techniques d'application des liquides antigivrage et dégivrants

Un certain nombre de lignes aériennes ont participé aux programmes d'essais menés par APS au cours des dernières années. Les essais ont montré que certains facteurs déterminants avaient pu varier d'une fois à l'autre. Entre autres, la technique d'application utilisée, l'habileté du personnel et le matériel utilisé. Ces facteurs ont une incidence sur la qualité de la protection des différentes surfaces d'un appareil, en particulier sur l'uniformité de l'application et la quantité de liquide appliquée.

Des essais spécialement conçus ont été menés pour vérifier et documenter l'influence de différentes techniques d'arrosage et des différents types de lances utilisés. Les chercheurs ont photographié et enregistré sur vidéo les différents essais et intégré les résultats dans un document audiovisuel qui a été présenté à l'occasion de plusieurs conférences et réunions tant nationales qu'internationales. Le document a été bien accueilli et des copies en ont été distribuées à un certain nombre de transporteurs aériens, de sociétés de service d'escale et de fabricants de liquides et de matériels de dégivrage, à des fins d'intégration dans les programmes de formation.

Détermination des surfaces de voilure visibles de l'intérieur d'un avion

Le personnel navigant ne peut pas toujours vérifier complètement l'état de givrage de l'appareil avant le décollage, notamment parce que sur certains avions, il est impossible de voir toutes les parties de la voilure. Les chercheurs ont pris une série de photos depuis l'intérieur de plusieurs appareils pour visualiser les limites des contrôles visuels, et ils ont pu déterminer que des lunettes d'approche offraient une vue beaucoup plus détaillée de l'état de surface des ailes.

Une documentation visuelle de l'aspect des ailes sous différentes conditions d'éclairage typiques et sous précipitations neigeuses ou verglaçantes aiderait à fixer les idées à ce sujet.

Recommandations

Les chercheurs recommandent d'étendre les essais aux appareils de transport régional, notamment au Regional Jet de Canadair et aux turbopropulseurs à voilure haute, ainsi que de pousser plus avant les recherches concernant l'exploitation opérationnelle de capteurs d'aile et de détecteurs de givrage à distance. Ils proposent également des procédures améliorées.

This page intentionally left blank.

CONTENTS	Page
1. INTRODUCTION	1
1.1 Background	1
1.2 Objectives	4
1.3 Report format	5
2. METHODOLOGY	7
2.1 Fluid Failure Characteristic	7
2.1.1 Test Sites and Facilities	7
2.1.2 Test Plan	9
2.1.3 Equipment	12
2.1.4 Description of Test Procedures	15
2.1.5 Data Forms	18
2.1.6 Fluids	18
2.1.7 Personnel	19
2.1.8 Analysis Methodology	20
2.2 Fluid Thickness	20
2.2.1 Test Sites	21
2.2.2 Test Condition/Plan	21
2.2.3 Equipment	23
2.2.4 Test Procedures	24
2.2.4.1 Fluid Thickness Trials on Jet Aircraft	24
2.2.4.2 Fluid Thickness Trials on Turboprop Aircraft	25
2.2.4.3 Fluid Application Trials	25
2.2.5 Data Forms	26
2.2.6 Fluids	26
2.2.7 Personnel	27
2.2.8 Analysis Methodology	27
3. DESCRIPTION AND PROCESSING OF DATA	43
3.1 Fluid Failure Characteristics	43
3.1.1 Overview of Test Sessions	43
3.1.2 Breakdown of Test Variables	46
3.1.3 Description and Reduction of Data Collected	49
3.1.3.1 General test information sheet (Figure 3.3)	49
3.1.3.2 Percentage of Fluid Failure by Wing Section Versus Time (Figure 3.4)	50
3.1.3.3 Brix Measurements (Figure 3.6)	53
3.1.3.4 Brix Versus Time (Figure 3.7)	53
3.1.3.5 Fluid Thickness on Wing Versus Time (Figure 3.8)	54
3.1.3.6 Precipitation Rate Versus Time (Figure 3.9)	55
3.1.3.7 Temperature Versus Time (Figure 3.10)	55
3.1.3.8 Wind Direction Versus Time (Figure 3.11)	55
3.1.3.9 Wind Speed Versus Time (Figure 3.12)	56
3.1.3.10 Mapping of Fluid Failure to Illustrate Progression	56
3.1.4 Secondary Data Reduction	59
3.1.4.1 Failure Histograms	59
3.1.4.2 Depiction of First Failure	61
3.1.4.3 Depiction of 10% Wing Failure (Figures 3.21 to 3.24)	66
3.1.4.4 Data Reduction of Wing Samples	69
3.1.5 Video and Still Photo Descriptions	71
3.1.6 Evolution of Test Procedures	74

3.2	Fluid Thickness Characteristics	75
3.2.1	Overview of Test Sessions.....	75
3.2.2	Breakdown of Test Variables	77
3.2.3	Descriptions of Fluid Thickness Data and Analysis	77
3.2.3.1	Fluid thickness Tests on Jet Aircraft.....	77
3.2.3.2	Fluid Thickness Tests on Propeller Aircraft	80
3.2.3.3	Fluid Application Trials at Mirabel.....	82
3.2.4	Description of Photos and Video	86
4.	ANALYSIS AND OBSERVATIONS	95
4.1	Fluid Failure Characteristics	95
4.1.1	Progression Patterns of Failure.....	95
4.1.1.1	Effect of Aircraft Type on The Pattern of Progression of Failure.....	95
4.1.1.2	Comparison of Upwind and Downwind Wings in Crosswind Conditions	99
4.1.1.3	Comparison of Headwind and Tailwind Conditions.....	102
4.1.1.4	Effect of Wind Speed on The Pattern of Progression of Failure	104
4.1.1.5	Effect of Precipitation Type on The Pattern of Progression of Failure.....	104
4.1.1.6	Effect of Precipitation Rate on The Pattern of Progression of Failure.....	105
4.1.1.7	Effect of Temperature on The Pattern of Progression of Failure.....	106
4.1.1.8	Effect of Fluid Type on The Pattern of Progression of Failure.....	106
4.1.1.9	Effect Of the Quantity of Type IV Fluid Applied.....	107
4.1.1.10	Effect of Engines On/Off on The Progression of Failure.....	108
4.1.2	Validity of the Representative Surface	109
4.1.3	Sensor Placement	110
4.1.3.1	Leading edge.....	111
4.1.3.2	Trailing Edge	113
4.1.3.3	Mid-wing Sections	114
4.1.3.4	Representative Surface.....	115
4.1.3.5	Overall Sensor Placement Summary	116
4.1.4	Holdover Time Correspondence	116
4.1.4.1	Comparison of Flat Plates and Wing	117
4.1.4.2	Comparison of Wing Failure Times to SAE Holdover Times	121
4.1.4.3	Correspondence of Flat Plate Holdover Times to SAE Holdover Times	124
4.1.4.4	Condition Of the Wing at the Occurrence of Plate Failure.....	124
4.1.4.5	Comparison of Flat Plates with Wing Ailerons and Spoilers (Fokker 100)	126
4.1.5	Appearance of Fluid Failure	128
4.1.5.1	Freezing Drizzle and Light Freezing Rain	128
4.1.5.2	Natural Snow	131
4.1.6	Depiction of Fluid Roughness	132
4.1.7	Documentation of Wing Area Visible to Flight Crew.....	135
4.2	Fluid Thickness	135
4.2.1	Fluid Thickness Measurements	136
4.2.1.1	Fluid Thickness on Jet Aircraft (Boeing 737).....	136
4.2.1.2	Fluid Thickness on Propeller Aircraft (ATR 42, DHC Dash 8)	141
4.2.2	Fluid Application Techniques	142
4.2.2.1	General	142
4.2.2.2	Fluid Application Trials at Mirabel.....	144

5. DISCUSSION AND CONCLUSIONS	159
5.1 Progression of Failure.....	159
5.2 Validity of the Representative Surface.....	161
5.3 Point Sensor Placement.....	161
5.4 Holdover Time Correspondence.....	162
5.5 Appearance of Fluid Failure.....	162
5.6 Evaluation of Roughness.....	163
5.7 Pilots' Field of View.....	163
5.8 Fluid Thickness Measurement.....	163
5.9 Fluid Application Techniques.....	164
5.10 Test Methodology.....	165
6. RECOMMENDATIONS	167
6.1 Progression of Failure.....	167
6.2 Location of Representative Surface/Sensor Placement.....	167
6.3 Value of Ice Sensors in the Deicing Operation.....	168
6.4 Appearance of Fluid Failure.....	168
6.5 Evaluation of Roughness.....	169
6.6 Pilots' Field of View.....	169
6.7 Fluid Thickness Measurement.....	169
6.8 Fluid Application Techniques.....	170
6.9 Evolution of Test Methodology.....	170
REFERENCES	171

LIST OF APPENDICES

- A Terms of Reference – Work Statement
- B Procedures for Conducting Tests on Jet Aircraft
- C Procedures for Conducting Tests on Propeller Aircraft
- D Fluid Thickness Trials on Jet Aircraft
- E Fluid Thickness Trials on Turboprop Aircraft
- F Documentation of Wing Area Visible to Flight Crew
- G Narrative Reports on Aircraft Tests 1996/97 Winter

This page intentionally left blank.

LIST OF TABLES	Page
Table 1.1: Listing of Aircraft Full-Scale Tests (1992 to 1997)	3
Table 2.1: Characteristics of Test Aircraft	10
Table 2.2: Test Plan for Fluid Failure Tests	10
Table 2.3: Test Plan for Turboprop Aircraft Thickness Tests.....	22
Table 2.4: Test Plan for Documenting Fluid Application	22
Table 3.1: Listing of Aircraft Fluid Failure Tests Conducted in 1996/97	45
Table 3.2: List of Photo References	72
Table 3.3: Video Log for Tests Conducted During 1996/97.....	73
Table 3.4: Listing of Aircraft Thickness Tests – Winter 1996/97	76

LIST OF FIGURES	Page
Figure 2.1: Deicing Pad Locations at Dorval Airport.....	8
Figure 2.2: Regional Forecast for Montreal, March 5, 1997.....	11
Figure 2.3: Flat Plate Test Set-up	14
Figure 2.4: Position of Equipment and Personnel.....	14
Figure 2.5: Wing Sample Locations.....	16
Figure 2.6: Wet Film Thickness Gauges.....	24
Figure 3.1: General Summary of Fluid Failure Tests Conducted	46
Figure 3.2: General Summary of Fluid Failure Tests Conducted	48
Figure 3.3: General Test Information.....	50
Figure 3.4: Percentage of Fluid Failure by Wing Section vs Time	51
Figure 3.5: Sub-Division of Wing	52
Figure 3.6: Brix Measurements for ID # 24	53
Figure 3.7: Brix vs Time, ID # 24	54
Figure 3.8: Film Thickness on Wing vs Time, ID # 24.....	55
Figure 3.9: Rate of Precipitation vs Time, ID # 24.....	56
Figure 3.10: Temperature vs Time, ID # 24	57
Figure 3.11: Wind Direction vs Time, ID # 24	57
Figure 3.12: Wind Speed vs Time, ID # 24	58
Figure 3.13: Progression of Failures, ID # 24	58
Figure 3.14: Progression of Failures, ID # 31	59
Figure 3.15: Tabulation of Failure Patterns on Wing* by Aircraft Type.....	60
Figure 3.16: Location of First Failure by Test ID	62
Figure 3.17: Occurrences of First Wing Failure by Wing Grid Location, Fokker 100.....	63
Figure 3.18: Occurrences of First Wing Failure by Wing Grid Location, Boeing 737-200	63
Figure 3.19: Occurrences of First Wing Failure by Wing Grid Location, McDonnell Douglas DC-9 Series 30.....	64
Figure 3.20: First Failure Locations of BAe 146 and Airbus A320 Tests.....	65
Figure 3.21: Occurrences of Failure by Wing Grid Location – 10% Wing Failure Level – Fokker 100	67
Figure 3.22: Occurrences of Failure by Wing Grid Location – 10% Wing Failure Level – Boeing 737-200.....	67
Figure 3.23: Occurrences of Failure by Wing Grid Location – 10% Wing Failure Level – McDonnell Douglas DC-9 Series 30	68
Figure 3.24: Percentage of Leading Edge Failure at 10% Wing Failure	68
Figure 3.25: Brix vs Glycol Concentration of Union Carbide ADF & Ultra+	70
Figure 3.26: Refractometer Readings of Wing Samples Relative to First Failure, Fokker 100, Type I, Location # 10	71
Figure 3.27: Types of Fluid Thickness Tests Conducted.....	77

Figure 3.28: Fluid Thickness Decay of Various Wing Positions	78
Figure 3.29: Type IV Fluid Thickness (Stabilized) Profile	79
Figure 3.30: Boeing 737 Stabilized Thickness on Wing Plan	79
Figure 3.31: ATR 42 Turboprop Stabilized Fluid Thickness – Type I Fluid	81
Figure 3.32: ATR 42 Turboprop Stabilized Fluid Thickness – Type IV Fluid	81
Figure 3.33: Fluid Application Trial – Nepiro Nozzle – Standard Operation	83
Figure 3.34: Fluid Application Trial – Akron Nozzle – Standard Operation	84
Figure 3.35: Fluid Application Trial – Elephant & Standard Nozzle – Narrow Stream	84
Figure 3.36: Fluid Application Trial – Elephant & Optional Nozzle – Standard Operation	85
Figure 3.37: Fluid Application Trial – Elephant & Optional Nozzle – Continuous Spray for Maximum Thickness	85
Figure 4.1: Example of the Progression of Failure of Related Downwind and Upwind Wing	101
Figure 4.2: Increase in Effective Precipitation Rate Due to Crosswind	102
Figure 4.3: Observed Rate of Wing Failure for Different Fluid Quantities	108
Figure 4.4: Comparison of Wing and Plate Failure Time for Type I Fluid	119
Figure 4.5: Comparison of Wing and Plate Failure Time for Type IV Fluid	120
Figure 4.6: Effect of Rate of Precipitation on Failure Time – Standard Type I	122
Figure 4.7: Effect of Temperature and Rate of Precipitation on Failure Time – Ultra+ Type IV Neat	123
Figure 4.8: Condition of the Wing at Occurrence of Plate Failure, Type I Fluid	125
Figure 4.9: Condition of the Wing at Occurrence of Plate Failure, Type II Fluid	125
Figure 4.10: Condition of the Wing at Occurrence of Plate Failure, Type IV Fluid	126
Figure 4.11: Aircraft Aileron and Spoiler Failure vs Average Plate Failure	127
Figure 4.12: General Conditions For 1996 Light Freezing Rain Tests	130
Figure 4.13: General Conditions For 1997 Light Freezing Rain Tests	130
Figure 4.14: Depiction of Type I Fluid Roughness on Fokker 100	134
Figure 4.15: Film Thickness of Various Type IV Fluids	138
Figure 4.16: Type IV Fluid Thickness (Stabilized) Profile – No Precipitation	139
Figure 4.17: Type IV Fluid Thickness (Stabilized) Profile of a DC-9, RJ, Airbus A320, and Boeing 737	140
Figure 4.18: Type IV Fluid Thickness (Stabilized) Profile – No Precipitation	142
Figure 4.19: Thickness Profile for Three Crews	143
Figure 4.20: Consistency of Fluid Thickness on Leading Edge	144
Figure 4.21: Preferred Locations for Sensor Placement	146

LIST OF PHOTOS

Page

Photo 2.1: Canadian Airlines International Boeing 737	29
Photo 2.2: American Airlines Fokker 100	29
Photo 2.3: Inter-Canadian ATR 42	30
Photo 2.4: Department of National Defence DHC Dash 8	30
Photo 2.5: American Airlines Deicing Vehicle Applying Fluid on a Fokker 100	31
Photo 2.6: Air Canada Deicing Control Centre at East Pad	31
Photo 2.7: APS Trailer at Dorval Airport	32
Photo 2.8: Inside of APS Trailer at Dorval	32
Photo 2.9: Precipitation Rate Measurement Equipment	33
Photo 2.10: Field Lab for Full-Scale Tests	33
Photo 2.11: Rolling Stairs and Step Ladders Positioned Around Aircraft	34
Photo 2.12: Mast Lighting Used for Aircraft Illumination	34
Photo 2.13: Fluid Sampling Location on Fokker 100 Wing	35
Photo 2.14: Collecting Samples of Fluid on Wing Surface	35
Photo 2.15: Portable Sampling Container Kit	36

Photo 2.16: Misco Refractometer Used to Measure Freeze Point of Samples 36

Photo 2.17: Hand-Held Ice Detection Sensor by RVSI ID-1H..... 37

Photo 2.18: Measurement of Fluid Thickness 37

Photo 2.19: Spray Application with Task Force Tips Nozzle 38

Photo 2.20: Spray Application with Wand 38

Photo 2.21: Test Set-up – ATR 42 Aircraft..... 39

Photo 2.22: Portable Flat Plate Stand..... 39

Photo 2.23: Test Set-up at Mirabel Airport Deicing Centre 40

Photo 2.24: Nepiro Type II Nozzle 40

Photo 2.25: Akron Type I Nozzle..... 41

Photo 2.26: Elephant β Standard and Optional Nozzle 41

Photo 2.27: ATR 42 Wing – Ribbed Deicing Boot 42

Photo 3.1: Fluid Beading on a DHC Dash 8 Wing 87

Photo 3.2: Nepiro Nozzle – Type IV Fluid After 20 Minutes..... 87

Photo 3.3: Akron Type I Nozzle – Type IV Fluid Application on Leading Edge 88

Photo 3.4: Akron Type I Nozzle – Type IV Fluid Application Over Wing..... 88

Photo 3.5: Akron Type I Nozzle – Type IV Fluid on Leading Edge..... 89

Photo 3.6: Akron Type I Nozzle – Type IV Fluid on Control Surfaces 89

Photo 3.7: Elephant β – Standard Nozzle – Adjusted to Reduced Pattern 90

Photo 3.8: Elephant β – Standard Nozzle – Adjusted to Narrow Stream 90

Photo 3.9: Elephant β – Standard Nozzle – Narrow Stream – Fluid on Leading Edge 91

Photo 3.10: Elephant β – Standard Nozzle – Narrow Stream – Fluid on Control Surfaces 91

Photo 3.11: Elephant β – Optional Fixed Nozzle 92

Photo 3.12: Elephant β – Optional Fixed Nozzle – Leading Edge 92

Photo 3.13: Elephant β – Optional Fixed Nozzle – Ultimate Thickness Trial 93

Photo 3.14: Elephant β – Ultimate Film Thickness Trial 93

Photo 4.1: McDonnell Douglas DC-9 Wing Surface During Freezing Rain Tests at Dorval
(Feb. 28, '96)..... 147

Photo 4.2: McDonnell Douglas DC-9 Wing Surface During Freezing Rain Tests at Dorval
(Feb. 28, '96)..... 148

Photo 4.3: Type IV Freezing Rain Failures on Boeing 737 Wing..... 149

Photo 4.4: Type I Test, Light Freezing Rain Precipitation..... 150

Photo 4.5: Type I Test on Boeing 737..... 151

Photo 4.6: Comparison of Type I and Type IV Failure 152

Photo 4.7: Snow Bridging Failures 153

Photo 4.8: Fluid Failure Patterns on Fokker 100 Trailing Edge..... 154

Photo 4.9: Examples of Photographs Used to Calculate Contamination Peak Height and
Density 155

Photo 4.10: Appearance of Fluid Layer Prior to Propeller Run 156

Photo 4.11: Appearance of Fluid Following Propeller Run..... 156

Photo 4.12: Appearance of Fluid at Edge of Propeller Wash Area..... 157

Photo 4.13: Appearance of Fluid in Propeller Wash Area..... 157

This page intentionally left blank.

GLOSSARY

APS	APS Aviation Inc.
DND	Department of National Defence
ISO	International Standard Organization
READAC	Remote Environmental Automatic Data Acquisition Concept
RVSI	Robotic Vision System Inc.
SAE	Society of Automotive Engineers

This page intentionally left blank.

1. INTRODUCTION

The following section will provide an outline of the testing that was undertaken by APS Aviation on behalf of the Transportation Development Centre of Transport Canada, including information relating to the background and overall objectives of the study, as well as an explanation of the report format.

1.1 Background

At the request of the Transportation Development Centre, APS undertook a research program to further advance aircraft ground deicing/anti-icing technology.

Aircraft ground deicing/anti-icing has been the subject of concentrated industry attention over the past decade as a result of a number of fatal aircraft accidents. Recent attention has been placed upon the enhancement of anti-icing fluids, in order to provide an extended duration of protection against further contamination following initial deicing. This has led to the development of fluid holdover time tables, for use by aircraft operators, and accepted by regulatory authorities. New fluids continue to be developed with the specific objective of prolonging fluid holdover times without compromising the aerodynamic features of the airfoil.

Flat plate tests, conducted in natural and simulated precipitation, are used to develop and substantiate holdover time tables for existing fluids and new formulations. Test procedures to measure duration of fluid protection against ice have evolved to a standard approach that has been followed by APS and others at a number of different locations in previous years.

The acceptance of increased holdover time durations for the new Type IV fluids, and the general recognition of the holdover time limitations of the Type I fluids, are direct results of the intensive test program carried out primarily by APS over this past decade.

Flat plate test results have been correlated against results from full-scale aircraft wing tests, and as a result, the flat plate has been validated as an adequate representation of the airfoil. For Type IV fluid, the results from the winter 1995/96 trials (1) showed that flat plate holdover times are equivalent to the time for failure to progress to about 10% or less of the entire wing area. Similar results were previously obtained with Type I fluid (2). The holdover time correspondence between aircraft wing and flat plate will be confirmed using data collected in the past year (1996/97).

The observation of fluid failure patterns on aircraft wings was the focal point of trials conducted during the past test season. The effects of variables such as wind speed, wind direction, wing type, and fluid type on the progression of failure on aircraft wings, were examined in detail.

Point sensors were developed to alleviate problems related to the detection of wing failures by flight crews. The use of these instruments has taken on an even greater importance due to the deceptive appearance of fluid failures in certain conditions, such as freezing rain. Sensors could provide valuable assistance to flight crews in the determination of wing conditions. The identification of adequate point sensor locations on aircraft wings was a point of intensive research for this project. The validity of the current representative surfaces on aircraft wings, as a method of determining early wing failures, was also examined.

APS began testing on full-scale aircraft in 1993, following fluid failure tests conducted by United Airlines in 1992. Since that time, APS has conducted tests on a wide variety of aircraft, at a number of locations, as reported in Table 1.1. Several different test objectives have been addressed, including assessment of fluid failure on aircraft wings, measurement of fluid thickness, evaluation of hot water deicing, examination of removal of frost with hot air, and study of cold-soaked wings.

The results and description of these tests can be found in Transport Canada report, TP 11836E (3) from 1992/93, the Test Results Summary from 1993/94, Transport Canada report, TP 12595E (2) from 1994/95 and Transport Canada report, TP 12901E (1) from 1995/96. The present report provides the results of tests conducted during the 1996/97 winter season.

1. INTRODUCTION

Table 1.1: Listing of Aircraft Full-Scale Tests (1992 to 1997)

Row #	ID #	Test Loc.	Date	A/C Type	Number of Tests	Start Time	Comments	Descr.	Row #	ID #	Test Loc.	Date	A/C Type	Number of Tests	Start Time	Comments	Descr.
1	5	BDL	Jul-18-96	MD-88	1			CSW	71	T4	YYT	Mar-01-95	DC-9	1	2:23		FF
2	1	YUL	Apr-15-96	MD-88	1			CSW	72	T5	YYT	Mar-01-95	DC-9	1	3:34		FF
3	2	YUL	Apr-18-96	MD-88	1			CSW	73	T5	YYT	Mar-01-95	DC-9	1	3:34		FF
4	3	YUL	Apr-18-96	RJ	1			CSW	74	T6	YYT	Mar-08-95	DC-9	1	2:18		FF
5	4	YUL	Apr-25-96	MD-88	1			CSW	75	T6	YYT	Mar-08-95	DC-9	1	2:18		FF
6		DEN	Jan. 14 - Mar. 21, 1992	B-737	22			Snow (TI & TII Fluids) United Airlines	76	T7	YYT	Mar-08-95	DC-9	1	3:11		FF
7		DEN	Nov. 20, 1992 - Mar 12, 1993	B-727	24			Snow (TI & TII Fluids) United Airlines	77	T7	YYT	Mar-08-95	DC-9	1	3:11		FF
8		YOW	March 18-19, 93	F-28 Wing Plate	10			Freezing Fog	78	T8	YYT	Mar-08-95	DC-9	1	3:45		FF
9		YOW	March 18-19, 93	King Air	11			Freezing Fog	79	T8	YYT	Mar-08-95	DC-9	1	3:45		FF
10		YOW	May-05-93	F-28 Wing Plate	9			Freezing Rain/Drizzle	80	T9	YYT	Mar-08-95	DC-9	1	4:18		FF
11		RIG	March 18-19, 93	King Air Wing Stabilizer	1			Simulated Snow	81	T9	YYT	Mar-08-95	DC-9	1	4:18		FF
12		YUL	Mar-10-94	Citation II - Metroliner	5				82		YMX	Mar-12-95	B-737	2		ZR - Allied Signal	FF
13	1	YUL	Jan-17-95	DC-9	1			Dry run	83	T10	YYT	Mar-15-95	BAe-146	1	1:23		FF
14	2	YUL	Jan-17-95	DC-9	1			Dry run	84	T10	YYT	Mar-15-95	BAe-146	1	1:23		FF
15	3	YUL	Jan-17-95	DC-9	1			Dry run	85	T11	YYT	Mar-15-95	BAe-146	1	3:05		FF
16		YTH	Feb-09-95	HS-748	2			Frost Removal - Calm Air	86	T11	YYT	Mar-15-95	BAe-146	1	3:05		FF
17	L1	YUL	Feb-24-95	DC-9	1	0:06			87		YUL	Mar-28-95	DC-9	4			HW
18	L2	YUL	Mar-06-95	DC-9	1	0:44			88		YUL	Apr-05-95	DC-9	4			HW
19	L3	YUL	Mar-06-95	DC-9	1	2:27			89		YUL	Apr-07-95	DC-9	3			HW
20	L4	YUL	Mar-06-95	DC-9	1	3:58			90	T12	YYT	Apr-27-95	DC-9	1	1:47		FF
21	L5	YUL	Mar-06-95	DC-9	1	4:47			91	T12	YYT	Apr-27-95	DC-9	1	1:47		FF
22	L6	YUL	Mar-08-95	DC-9	1	23:37			92	T13	YYT	Apr-27-95	A320	1	3:10		FF
23	L7	YUL	Mar-09-95	DC-9	1	1:52			93	T13	YYT	Apr-27-95	A320	1	3:10		FF
24	L8	YUL	Mar-09-95	DC-9	1	2:35			94	T14	YYT	Apr-27-95	A320	1	4:39		FF
25	L9	YUL	Mar-09-95	DC-9	1	3:44			95	T14	YYT	Apr-27-95	A320	1	4:39		FF
26	1	YUL	Feb-28-96	DC-9	1	2:25		Dry run	96	1	YYZ	Jan-05-95	B-737	1		Dry run	FF
27	1	YUL	Feb-28-96	DC-9	1	2:25			97	2	YYZ	Jan-05-95	B-737	1		Dry run	FF
28	2	YUL	Feb-28-96	DC-9	1	4:04			98	3	YYZ	Jan-05-95	B-737	1		Dry run	FF
29	39	YUL	Dec-13-96	F100	1			Dry run	99	Z1	YYZ	Feb-21-95	B-737	1	0:48		FF
30	40	YUL	Dec-13-96	F100	1			Dry run	100	Z2	YYZ	Feb-21-95	B-737	1	2:14		FF
31	1	YUL	Jan-16-97	B-737	1	4:07			101		YUL	Mar-10-94	Fairchild Metroliner	1			FT
32	2	YUL	Jan-16-97	B-737	1	4:14			102		YMX	Mar-23-95	B-737	1		Allied Signal	FT
33	3	YUL	Jan-16-97	B-737	1	5:14			103	1	YUL	14-15 Feb. 1996	RJ	1			FT
34	4	YUL	Jan-16-97	B-737	1	5:16		Test stopped	104	2	YUL	14-15 Feb. 1996	RJ	1			FT
35	5	YUL	Jan-22-97	B-737	1	3:54			105	3	YUL	14-15 Feb. 1996	RJ	1			FT
36	6	YUL	Jan-22-97	B-737	1	4:01			106	4	YUL	14-15 Feb. 1996	RJ	1			FT
37	8	YUL	Jan-22-97	B-737	1	4:38			107	1	YUL	11-12 Mar. 1996	DC-9	1			FT
38	9	YUL	Jan-25-97	B-737	1	2:30			108	2	YUL	11-12 Mar. 1996	DC-9	1			FT
39	10	YUL	Jan-25-97	B-737	1	2:35		Test stopped	109	3	YUL	11-12 Mar. 1996	DC-9	1			FT
40	13	YUL	Jan-28-97	B-737	1	1:54			110	4	YUL	11-12 Mar. 1996	DC-9	1			FT
41	14	YUL	Jan-28-97	B-737	1	2:06			111	5	YUL	11-12 Mar. 1996	DC-9	1			FT
42	15	YUL	Jan-28-97	B-737	1	2:39			112	6	YUL	11-12 Mar. 1996	DC-9	1			FT
43	16	YUL	Jan-28-97	B-737	1	3:32			113	1	YUL	28-29 Mar. 1996	A320	1			FT
44	17	YUL	Jan-28-97	B-737	1	4:09			114	2	YUL	28-29 Mar. 1996	A320	1			FT
45	18	YUL	Feb-05-97	F100	1	1:38			115	3	YUL	28-29 Mar. 1996	A320	1			FT
46	19	YUL	Feb-05-97	F100	1	2:14			116	4	YUL	28-29 Mar. 1996	A320	1			FT
47	20	YUL	Feb-05-97	F100	1	2:51			117	5	YUL	28-29 Mar. 1996	A320	1			FT
48	21	YUL	Feb-05-97	F100	1	3:40			118	1	YUL	Dec-13-96	F100	1			FT
49	22	YUL	Feb-05-97	F100	1	4:18			119	2	YUL	Dec-13-96	F100	1			FT
50	23	YUL	Feb-05-97	F100	1	4:23			120	3	YUL	Jan-16-97	B-737	1			FT
51	24	YUL	Feb-21-97	B-737	1	1:45			121	4	YUL	Jan-22-97	B-737	1			FT
52	25	YUL	Feb-21-97	B-737	1	1:53			122	5	YUL	Jan-25-97	B-737	1			FT
53	26	YUL	Feb-21-97	B-737	1	2:37			123	6	YUL	Jan-25-97	B-737	1			FT
54	29	YUL	Mar-06-97	F100	1	1:30			124	7	YUL	Feb-04-97	ATR 42	1			FT
55	30	YUL	Mar-06-97	F100	1	1:41			125	8	YUL	Feb-04-97	ATR 42	1			FT
56	31	YUL	Mar-06-97	F100	1	2:18			126	9	YUL	Feb-07-97	ATR 42	1			FT
57	32	YUL	Mar-06-97	F100	1	3:24			127	10	YUL	Feb-07-97	ATR 42	1			FT
58	33	YUL	Mar-06-97	F100	1	3:27			128	11	YUL	Feb-21-97	B-737	1			FT
59	34	YUL	Mar-06-97	F100	1	3:52			129	12	YWG	Mar-08-97	DHC-8	1			FT
60	35	YUL	Mar-06-97	F100	1	3:59			130	13	YWG	Mar-08-97	DHC-8	1			FT
61	36	YUL	Mar-14-97	ATR 42	1	11:36			131	14	YWG	Mar-08-97	DHC-8	1			FT
62	37	YUL	Mar-14-97	ATR 42	1	12:17			132	15	YWG	Mar-08-97	DHC-8	1			FT
63	38	YUL	Mar-14-97	ATR 42	1	12:20			133	16	YWG	Mar-08-97	DHC-8	1			FT
64	T1	YYT	Feb-23-95	DC-9	1	1:23			134	17	YWG	Mar-08-97	DHC-8	1			FT
65	T1	YYT	Feb-23-95	DC-9	1	1:23			135	18	YMX	Apr-09-97	B-737	1			FT
66	T2	YYT	Feb-23-95	DC-9	1	2:57			136	19	YMX	Apr-09-97	B-737	1			FT
67	T2	YYT	Feb-23-95	DC-9	1	2:57			137	20	YMX	Apr-09-97	B-737	1			FT
68	T3	YYT	Mar-01-95	DC-9	1	0:45			138	21	YMX	Apr-09-97	B-737	1			FT
69	T3	YYT	Mar-01-95	DC-9	1	0:45			139	22	YMX	Apr-09-97	B-737	1			FT
70	T4	YYT	Mar-01-95	DC-9	1	2:23			140	23	YMX	Apr-09-97	B-737	1			FT

FF = Fluid Failure
 CSW = Cold-Soaked Wing
 HW = Hot Water
 HA = Hot Air
 FT = Fluid Thickness

1.2 Objectives

The primary objective of this project was to determine the influence of fluid type, precipitation, and wind on the location and time to fluid failure initiation, and to document failure progression on service aircraft. The detailed work statement is contained in Appendix A.

To support the primary objective, several detailed objectives were subsequently defined and are listed below:

- To generate data which can be used to assist pilots with visual identification of fluid failure; this objective was addressed by performing fluid failure tests and observing the progression and appearance of fluid failure;
- To assess a pilot's field of view during adverse conditions of winter precipitation for selected aircraft; this objective was addressed with a series of photographs that document the area of the wing that is visible to the flight crew;
- To assess whether Representative Surfaces can be used to provide a reliable first indication of anti-icing fluid failure; observations related to the validity of the visual inspection of representative surfaces, as a method to determine early failures, were obtained during fluid failure tests on aircraft wings;
- To explore the potential application of point detection sensors to warn the pilot-in-command of an unsafe to take-off condition; this objective was addressed using the progression of failure and fluid sample data obtained during fluid failure tests;
- To obtain failed fluid contamination distributions and profiles, which can serve as inputs to a theoretical program designed to assess the effects of such contamination on aircraft take-off performance; this objective was addressed primarily through the collection of fluid samples, and the data relating to progression of failure; and
- To compare the performance of de/anti-icing fluids on aircraft surfaces with the performance of de/anti-icing fluids on flat plates; this objective was satisfied by comparing the failure times of fluid on aircraft wings and flat plates in natural precipitation.

A secondary objective of the study was to determine the distribution of fluid thickness on the wing surface, as the fluid layer stabilized over time, including an examination of the impact of propeller wash on the fluid layer. This objective was addressed by performing fluid thickness measurement tests during periods of no precipitation, in the course of fluid failure tests. Special sessions were arranged to conduct thickness tests on propeller aircraft.

A supplemental objective, established during the test season, was to document the influence of different spray techniques and different spray nozzles on the resultant fluid layer on the aircraft wing. This objective was addressed by arranging a special session, during which a number of spray nozzles and techniques were used. A complete video and photographic record was compiled.

1.3 Report format

This report is presented in six parts, with Section 1 being the general introduction. The following list provides short descriptions of the contents of the remaining sections in the report.

- Section 2 describes the test conditions, methods, equipment, and personnel requirements necessary to conduct the full-scale tests.
- Section 3 provides descriptions of the test data and procedures used to process the data from fluid failure and fluid thickness tests.
- Section 4 provides the complete analysis of the data collected during the course of full-scale testing.
- Section 5 presents discussion and conclusions derived from the complete test program.
- Section 6 lists recommendations.

This page intentionally left blank.

2. METHODOLOGY

This section of the report details the complete environments surrounding testing, including information about test facilities, equipment, procedures, and personnel. The section is broken down into two parts, fluid failure characteristics and fluid thickness representing the main focal points of the study.

2.1 Fluid Failure Characteristic

This subsection of methodology characterizes testing that was concentrated on identifying and evaluating characteristics associated with failure on fluids.

Failure time is defined as the time required for the end condition to be achieved. This occurs when the accumulating precipitation fails to be absorbed by the fluid.

A surface is failed if:

- There is a visible accumulation of snow on the fluid or on the wing surface; or
- Ice has formed on the wing surface.

2.1.1 Test Sites and Facilities

All APS aircraft fluid failure tests in the 1996/97 winter were conducted at Dorval International Airport, Montreal. Consideration was given to conducting tests at Pearson International Airport, Toronto, Ottawa International Airport (Uplands), Bradley Air Field, Hartford, Connecticut, and Ancienne Lorette Airport, Quebec City; however this did not prove to be necessary.

Dorval Airport has four dedicated areas where deicing operations occur, commonly referred to as the north, east, west, and south deicing pads (see Figure 2.1). Tests were conducted at three of these pads as follows:

- The dry run test was conducted at the west deicing pad;
- Tests with turboprop aircraft were conducted at the north pad; and
- Tests with Boeing 737 aircraft were conducted on the east pad, which had been used for aircraft tests conducted by APS during previous winters.

A fourth location was utilized for the Fokker 100 tests. The operator of this aircraft had safety concerns regarding towing the aircraft to the west pad under inclement weather conditions, hence approval was requested and obtained from the local

airport authority (Aéroports de Montréal) to conduct tests just south of Gate 16 (designated by an "X" on Figure 2.1). Arrangements were made with Hudson General to sweep up as much spent fluid as possible.

At the beginning of the winter season, it appeared that the west pad would be used most frequently. To accommodate this location, Air Canada's ground support equipment manager authorized APS to install a test trailer facility in their equipment storage area on the west side of the airport (designated by a "T" on Figure 2.1). This trailer was used for storage of equipment and for meeting purposes at the start of the test session. A second facility, the Air Canada deicing centre, was also used when tests were conducted on the east pad. This was the same facility used during winter 1994/95 and winter 1995/96 testing.

The APS test site (where flat plate tests to determine holdover times are conducted) is also indicated in Figure 2.1, as is Environment Canada's automated weather station.

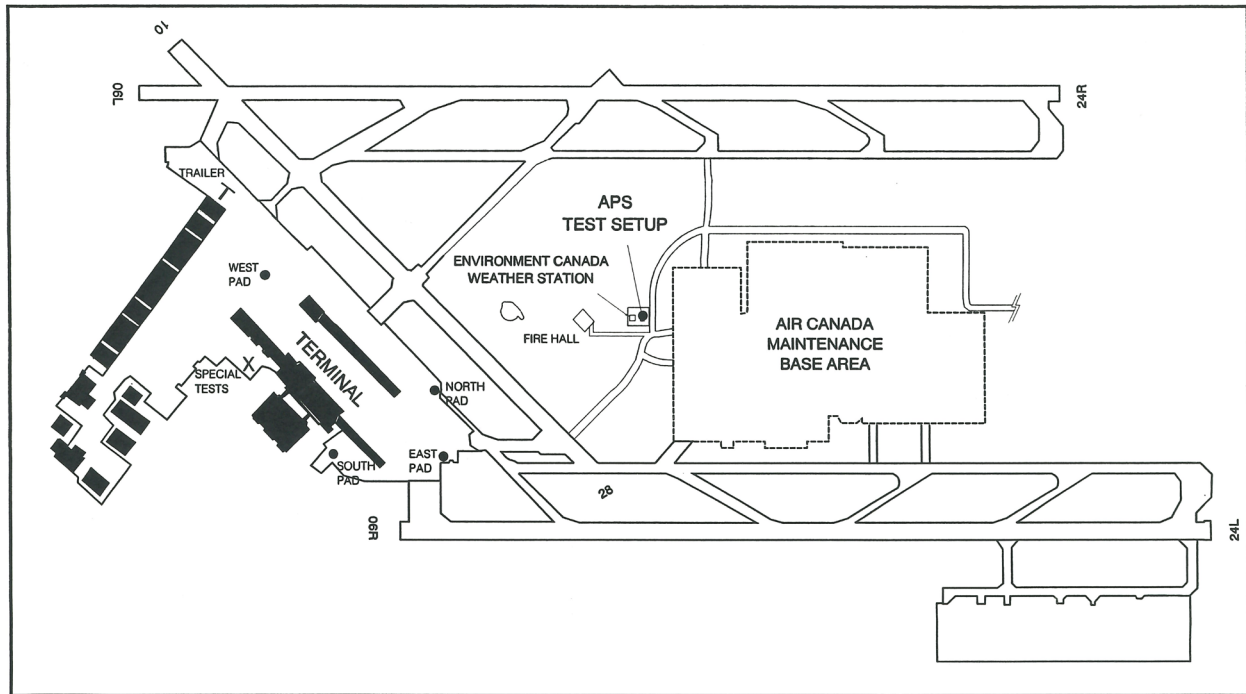


Figure 2.1: Deicing Pad Locations at Dorval Airport

2.1.2 Test Plan

A dry run and up to eight full test sessions were planned for winter 1996/97. Planning of the tests was based on the following aircraft and operators:

Aircraft	Airline
Fokker 100	American Airlines
Canadair Regional Jet	Commitment sought from several sources
Boeing 737	Canadian Airlines International
ATR 42	Inter-Canadian
DHC Dash 8	Canadian Regional/DND

Schematics and views of the aircraft are included as part of the procedures document in Appendix B. A summary of some of the most relevant characteristics relating to this project for each aircraft is provided in Table 2.1. The McDonnell Douglas DC-9, the Airbus A320, and the BAe 146 were added to the table to enable comparison with tests from previous years.

Test sessions on jet aircraft were planned after normal daily operating times, between 23:00 and 06:00. The ATR 42 aircraft was available for several hours during the middle of the day.

Tests were planned under the following conditions:

Aircraft Orientation	⇒	headwind, tailwind, crosswind
Precipitation Type	⇒	snow, freezing rain, freezing drizzle
Fluids	⇒	Type I (mostly), Type IV
Engines	⇒	operating for turboprop tests

Table 2.1: Characteristics of Test Aircraft

Aircraft	Wing Span (m)	Wing Area (m ²)	Wing Dihedral (°)	Wing Sweep (°)	Slats on Leading Edge
F100	28	94	2	17	No
RJ	21	55	2	24	No
B-737-100/200	28	102	6	25	Yes
ATR 42	25	55	2	3	No
BAe 146	26	77	3*	15	No
A320	34	122	5	25	Yes
DHC-8	26	54	2	0	No
DC-9-30	28	93	3	24	Yes

* For BAE-146, the wing is anhedral.

Table 2.2: Test Plan for Fluid Failure Tests

OCCASION	RUN #	FLUID ⁽¹⁾ TYPE	A/C ORIENTATION
1	1	I/IV	Tail
1	2	I	Tail
1	3	I	Tail
1	4	I/IV	Cross
1	5	I/IV	Cross
1	6	I	Cross
1	7	I	Cross
1	8	I/IV	Head
1	9	I	Head
1	10	I	Head

(1) Selection of fluid is dependent upon precipitation rate.



Environment Canada Atmospheric Environment Service
Environnement Canada Service de l'Environnement Atmosphérique

Montreal, Quebec

Current Conditions

Cloudy

- Temperature: -1.3 °C
- Barometer: 102.06 kPa
- Wind Speed: N 3.6 km/h
- Dew Point: -5.4 °C
- Relative Humidity: 74%
- Latest Observation: 12:00 EST, 5 March 1997

Regional Forecast

SNOW AND BLOWING SNOW WARNING

Today

- Cloudy with clear periods and 30 percent probability of flurries. High near minus 1. Winds northeasterly 15 to 30 km/h this evening.

Tonight

- Snow and blowing snow. Low near minus 6. Winds northeasterly 30 to 50 km/h.

Thursday

- Snow becoming intermittent. Total accumulation near 10 centimetres. High near minus 2. Winds northeasterly 30 to 50 km/h becoming northwesterly 20 to 40 and causing blowing snow.

Friday

- Sunny. Low near minus 11. High near minus 4.

Saturday

- Mostly sunny. Low near minus 14. High near minus 4.

3/5/97

12:16:02 PM

Figure 2.2: Regional Forecast for Montreal, March 5, 1997

Tests were scheduled based on a reasonable forecast of precipitation for the evening/overnight, provided that the airline was available to support and participate in the tests.

Forecasts were monitored daily using radio, television, and Internet sources. An example of a forecast obtained from the Internet for Montreal is shown in Figure 2.2. This forecast prompted an alert which was issued to all test and airline personnel related to potential tests to be conducted on Thursday March 6, 1997. Closer monitoring of the weather system was carried out as the storm approached. This was done via direct one-to-one telephone communication with a trained Environment Canada professional using their 1-900 service.

For each session, up to ten tests were planned (see Table 2.2) using both Type I and Type IV fluid. Aircraft were positioned at a pre-determined orientation prior to the start of the first test. The plan was to re-orient the aircraft relative to wind direction during the course of the session.

2.1.3 Equipment

Nine full-scale test sessions were conducted in the 1996/97 winter season at Dorval Airport. Test aircraft were provided by Canadian Airlines International (Boeing 737), American Airlines (Fokker 100), and Inter-Canadian (ATR 42). In addition, one thickness test was performed on a DHC Dash 8 at the Department of National Defence in Winnipeg. The set-ups of these four aircraft are shown in Photo 2.1 to Photo 2.4 (photos are included at the end of this section). Fluids used for the full-scale tests were sprayed by the airlines and by the Department of National Defence. Photo 2.5 shows a deicing vehicle applying fluid onto a Fokker 100 aircraft during a full-scale test.

Photo 2.6 shows Air Canada's deicing control centre at the east deicing pad. The APS trailer, measuring 4 x 13.3 m (12 x 40 ft), is shown in Photo 2.7 and Photo 2.8.

Photo 2.9 shows the equipment used to measure precipitation. Two collection pans were used for collecting precipitation, and a scale, shielded with plexiglass to prevent wind effects, was used to weigh the precipitation. The rate station was positioned on a table in a rented truck stationed near the test stand. Photo 2.10 shows the truck used during the full-scale tests. The van was also used as an office for debriefing in between tests.

Six rolling stairs and several stepladders (see Photo 2.11) were positioned around the aircraft wings. Each wing was adequately illuminated with a 2500 W mast light supported on a scaffold. The mast lights had a stated useful range of 13.3 m (40 ft) but were sufficiently powerful for use at longer distances. Portable gasoline-powered generators were used to supply current for all electrical requirements. Photo 2.12 shows the mast light ready for testing.

Tests were also conducted on two flat plates mounted on a 10° inclined stand. The plates were marked with three parallel lines, 2.5 cm (1"), 15 cm (6") and 30 cm (12") from the top of the plates. The plates were also marked with 15 cross hairs which served as criteria for the calling of fluid failure on flat plate test surface. Figure 2.3 shows a schematic of the stand and the test plate used for testing, and Figure 2.4 provides a schematic of the positioning of the major equipment about the aircraft.

A list of the mobile equipment used by each of the testers is shown on pages B-27 and B-28 of Appendix B. A list of the mobile equipment required for the truck is shown on page B-29 of Appendix B. Some of the equipment on these lists will be explained later in this section in greater detail.

Marking kits were employed to indicate fluid sampling positions on each wing (see Photo 2.13). Sampling kits, consisting of spatulas and small collection and storage containers, were used to collect fluid samples on the predetermined wing locations (see Photo 2.14). Photo 2.15 shows the sampling containers in the portable tray, which is specially designed to transport the full sampling during testing. The freeze points of the sample fluids collected were measured at the APS test site using a hand-held refractometer with a Brix-scale. Photo 2.16 shows the Misco refractometer which was used.

Photo 2.17 shows the hand-held ID-1H ice contamination sensor unit provided by Robotic Vision Systems Inc. (RVSI). The unit consists of a hand-held sensor used to scan the wing surface and measure the ice intensity, a main power supply, and image storage unit. The entire system is portable.

Two video cameras and a still camera were used to record fluid failures on wings and plates, and on one occasion, a rented digital video camera was used to assess whether better quality images would result.

Four VHF radios were rented to allow communication between coordinators and video personnel.

Meteorological data, such as temperature, wind speed, and wind direction, were provided by the Remote Environmental Automatic Data Acquisition Concept (READAC), which is located within a 2 km radius of the aircraft test locations. (Refer to Transport Canada holdover time reports (4, 5) for complete descriptions of the READAC instruments). Figure 2.1 shows the location of the READAC station and test locations.

Wing skin temperature was recorded using a temperature probe mounted on an extension pole. A hand-held anemometer was acquired during the test season and used to measure local wind speed. A list of test equipment used for the Dorval aircraft full-scale test program is given in Appendix B, Attachment II, Test Equipment Checklist.

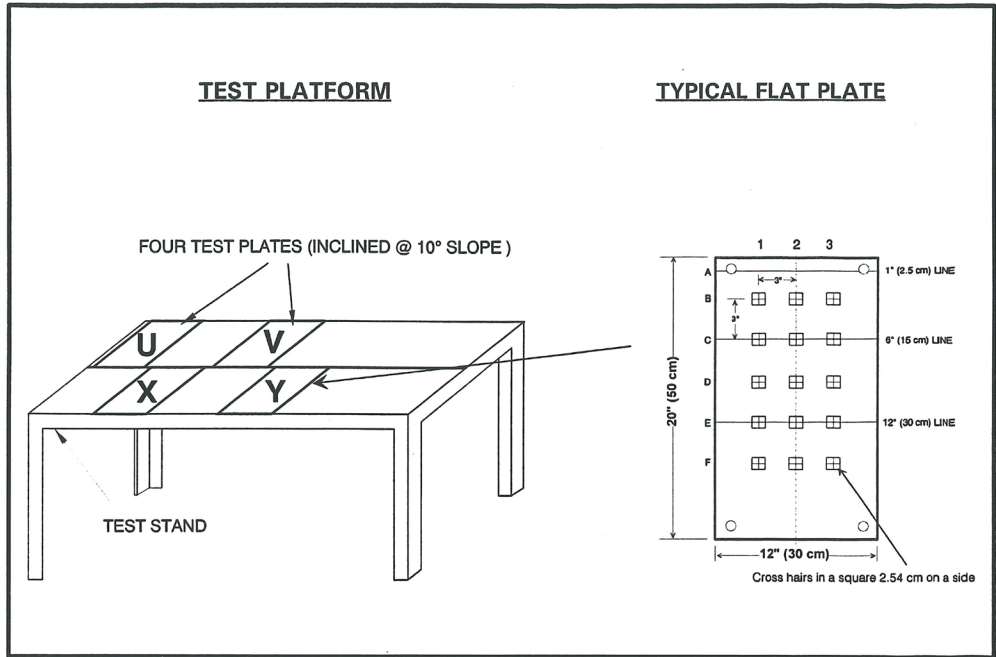


Figure 2.3: Flat Plate Test Set-up

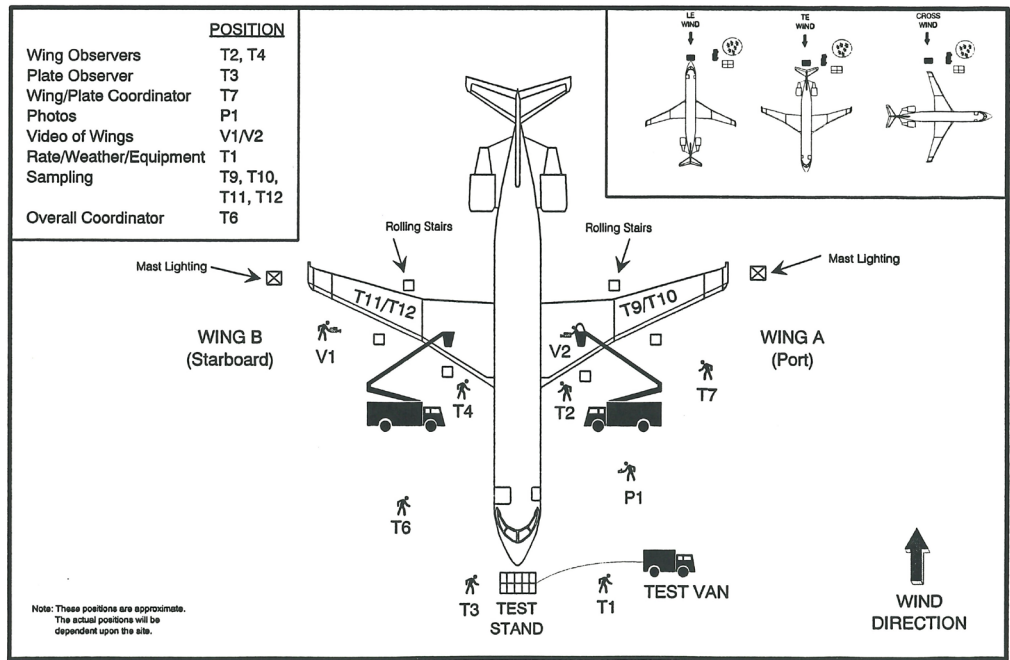


Figure 2.4: Position of Equipment and Personnel

2.1.4 Description of Test Procedures

The APS document *Experimental Program for Simultaneous Aircraft versus Plate Testing* is provided in Appendix B. It describes the detailed procedures employed during the course of full-scale testing.

APS continuously monitored weather forecasts throughout the test season in order to anticipate conditions that would require aircraft deicing. If these conditions were forecast, the test team was put on alert 48 hours ahead of the predicted event. Confirmation of the freezing precipitation event was followed by contacting airlines to secure a test aircraft. Arrangements were then made with an airport security company for security escorts. Test equipment, such as trucks, mast lights, and generators were rented. Transport Canada and other companies working in conjunction with APS Aviation, such as Optima Specialty Chemicals and Technology (wing sample collection) were then alerted. Aéroports de Montréal Ramp Control was contacted for snow removal and for authorization to set-up test equipment. Arrangements were also made for waste fluid collection following tests.

Fluid application procedures varied somewhat from previous years. In the past, each wing test had several corresponding flat plates, whereas tests conducted in 1996/97 had only two corresponding plates. Type IV fluids for the tests were prepared and stocked in marked red polyethylene fuel containers at the APS test site. These were stored outdoors at ambient temperature and were transported to the full-scale test site with the equipment necessary for testing. The Type IV fluids were applied directly from these containers to flat plates by pouring. Type I fluids were stored indoors and applied warm. The standard flat plate test one-step fluid application procedure was used. The fluid application procedures for 1996/97 are shown in Figure 2a (page B-31 of Appendix B).

Fluid samples were collected by APS on an ongoing basis during testing. In addition, Optima collected a limited number of Type IV fluid samples.

APS samples were collected at several pre-determined points on the aircraft wings as shown in Figure 2.5 for Boeing 737 and Fokker 100 aircraft. Samples were collected in sequence from location # 1 to # 11. It was found that some predefined locations at mid-wing were not suitable for sampling because of the long reach required.

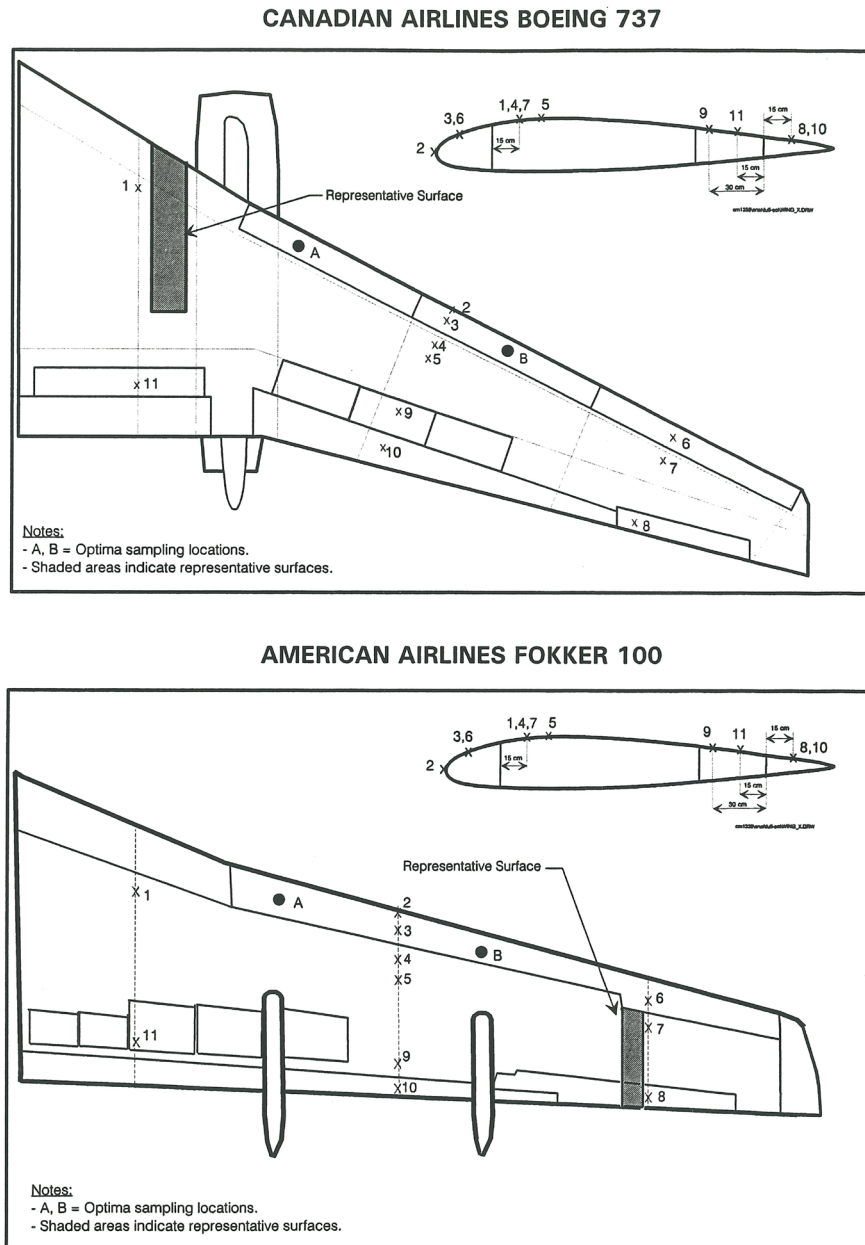


Figure 2.5: Wing Sample Locations

Sampling intervals for Type IV fluid were every 15 minutes. Initially, Type I fluid was sampled immediately following first failure on the wing, and at the end of the test. Because of the rapid progression of failure of Type I fluid, the procedure was changed (subsequent to tests on February 5, 1997) to collect initial samples during an interval of two to five minutes following fluid application.

Fluid samples were lifted with the use of spatulas, and placed in sealed pre-marked plastic bottles in the sampling kit. Following the end of the test session, fluid samples

were measured for refractive index with a hand-held refractometer. The initial session identified a possible problem with evaporation of the fluid sample prior to measurement. For later tests, larger samples were collected, and the samples were kept cold, and tested more promptly.

The sampling procedure is contained in Appendix B, Attachment V.

Optima collected Type IV fluid samples at points representing installation locations for point sensors, identified as locations A and B in Figure 2.5.

In previous years, rates of precipitation were measured during tests at 15-minute intervals. In order to obtain more precise rates (especially for Type I tests), the test procedure was modified to measure rates every five minutes.

The video and photo recording procedures are also described in Appendix B. In the original procedure, there was one video recorder for the aircraft wings and one for the flat plates. The flat plate video recorder was also responsible for taking photographs of the plates and wings. This procedure was modified during the 1996/97 test season, such that one video recorder was assigned to each wing of the aircraft, with one photographer concentrating solely on taking photographs. A photo procedure was developed for documenting roughness of the failed fluid; this is included in Appendix B (page B-59).

A portable ice detection unit was provided by RVSI. The procedure for use of the unit is provided in Appendix B. At the time of initial fluid application, the operator of the unit was requested to take an image of the tail identification number of the aircraft in order to determine the start of the holdover time period. The grid structure on page B-66 of Appendix B was used to determine the order of images taken by the RVSI operator. An entire series of images covering the wing was to be performed every 15 minutes. At the end of the test, the tail numbers were to be recorded again with the unit to indicate the end of test and that all the previous images were associated with this particular aircraft.

The data forms used to draw failure contours during full-scale tests were changed following the full-scale test session on January 25, 1997. An example of the original form used is shown on page B-36 of Appendix B. Using a separate form for each test, the wing observer would draw failure contours as they occurred, noting the times of failure. As a result, the forms were very congested, and the information contained on them was often not clear. The procedure and data sheet were changed so that wing failure contours were drawn at specified times. An example of the amended data sheet is shown on page B-40 of Appendix B. The progression of fluid failure was drawn at wing first failure and every five minutes thereafter for Type I tests, and at first failure and every 15 minutes thereafter for Type IV tests. As a result of this change in procedure, the clarity of the failure drawings were enhanced and the progression of failure with time was easier to map.

In the full-scale test procedure, plans were made to test each aircraft in headwind, tailwind and crosswind conditions. Aircraft were rotated by airline support personnel to expose the aircraft to a different wind condition.

2.1.5 Data Forms

Several different data forms were used during full-scale tests in 1996/97. The General Form - every test - (see Appendix B, Figure 3, page B-32) was completed by the plate/wing coordinator (T7) for every test, and information such as the type, temperature and quantity of fluid sprayed, as well as the start and end times of the fluid applications were recorded. A second General Form - once per session - (see Appendix B, Figure 3a, page B-33) was completed by the overall coordinator (T6) once per session, and contains information relating to the aircraft, fluids and initial aircraft skin temperatures.

The third data form is the Aircraft Wing Form. Appendix B (page B-36) shows the form used for initial tests on the Boeing 737. Forms were also produced for the Canadair Regional Jet, Fokker 100, and the ATR 42/DHC Dash 8, and these forms appear in Appendices B and C. Wing observers were assigned to identify fluid failures and draw failure contours on the wing diagrams.

Figure 5 in Appendices B and C shows the Sampling Data Form. For jet aircraft, this form appears on page B-48, while for turboprops, it appears on page C-31. These forms were filled out by the samplers/data loggers (T10 and T12) and contain information related to wing fluid sample collection and thickness measurements. The Fluid Thickness General Forms (see pages B-49 and C-25) are shown in Figure 6 of Appendices B and C. These forms were filled out by the samplers/data loggers (T10 and T12) and contain information related to thickness measurements.

The End Condition Data Form (see Appendix B, Table 1, page B-50) was completed by the end condition tester (T3) and contains information relating to fluid failure times on the flat plates. The Meteo/Plate Pan Data Form (see Appendix B, Table 2, page B-51) was completed by the meteo/equipment tester (T1) and contains information on the weather conditions and rates of precipitation.

2.1.6 Fluids

The Type I and Type IV fluids used in full-scale tests were provided by Union Carbide. Only fluids from Union Carbide were tested since these were the only fluids available in American Airlines, Canadian Airlines International, and Inter-Canadian de/anti-icing vehicles. Type I ADF was applied in standard concentration (XL54), and Type IV Ultra + was applied in its neat concentration. It should be noted that the first Type IV

full-scale fluid failure test (ID # 7) was performed using a fluid that was unusually pale and thin. Samples of this fluid were collected from the Canadian Airlines International truck and sent to Union Carbide for analysis. Union Carbide advised that the Type IV fluid was old Ultra, and that the fluid viscosity was severely degraded due to numerous heating and cooling cycles. The old fluid was disposed of, and subsequent Type IV tests were performed with Ultra +.

2.1.7 Personnel

Up to fourteen people were required for each full-scale test session. Figure 2.4 provides a schematic description of the general test set-up, as well as the location of each of the full-scale testers. All personnel were involved in setting up equipment prior to tests. The primary roles and responsibilities of each personnel member are listed below:

- **Wing Observers (T2, T4):** Responsible for drawing failures as they occurred on the wing surface;
- **Plate Observer (T3):** Responsible for holdover time tests on flat plates during full-scale testing;
- **Wing/Plate Coordinator (T7):** Responsible for ensuring consistency between wing and plate failure calls;
- **Photographer (P1):** Responsible for taking photographs of the test sessions;
- **Video Recorder (V1, V2):** Responsible for taking video recordings of the wings, with particular attention on the fluid contamination and failure;
- **Rate/Weather/Equipment (T1):** Responsible for recording all meteo and rate of precipitation information;
- **Sampler (T9, T11):** Responsible for the collection of fluid samples at predetermined wing locations;
- **Sampler/Data Logger (T10, T12):** Responsible for the recording of all information related to thickness measurements and fluid sample collections; and
- **Overall Coordinator (T6):** Responsible for coordinating all aspects of the full-scale tests. The overall coordinator was also responsible for safety awareness training (based on guidelines that appear in Attachment VI of Appendix B) and ensuring that safety measures were being respected during the course of full-scale testing.

Attachment III of Appendix B *The Responsibilities/Duties of Test Personnel* contains full descriptions of tester responsibilities, individual duties, and positions.

One additional person was required to measure the refractive index of the wing samples collected during the course of full-scale testing. These measurements were performed at the APS test site following each aircraft test session. Personnel from Optima collected fluid samples on several occasions during Type IV fluid tests. As well, ground support personnel from the airlines were available to apply fluids and position the aircraft.

The process of setting up experiments was complicated by the remoteness of the various deicing pad locations. Principal set-up activities included; transportation of equipment and personnel to and from the site, set-up of generators and lighting, set-up of a mobile lab in a van, and installing observation markers on the aircraft. To ensure that set-up proceeded in the most expeditious and efficient manner, the various set-up tasks were plotted and assigned in a process flow chart (Appendix B, page B-23, Attachment VII).

2.1.8 Analysis Methodology

The description and reduction of the data acquired during the full-scale tests are presented in Section 3 of this report. Charts, figures and drawings related to the progression of failure, holdover time correspondence, fluid thickness, fluid application, and sensor positioning are presented and discussed in that section. Video recordings and still photographs of the individual test sessions are described in Section 3.

The effects of specific variables, such as aircraft type, fluid type, temperature, wind direction, and wind speed on the progression of failure is discussed in Section 4. Data for aircraft wings were sorted into sections (i.e. leading edge, trailing edge, mid-wing) in order to determine ideal locations for sensor positioning.

The correspondence of wing failure times and holdover times (Subsection 4.1.4) was evaluated using the failure contour drawings, as explained in Section 3. Wing and flat plate failure times, as well as the percentage of wing failure at plate failure time, were compared. Flat plate, wing aileron, and spoiler failure times were compared to ascertain any similarities among these surfaces.

Conclusions and recommendations based on the analysis of the data appear in Sections 5 and 6, respectively.

2.2 Fluid Thickness

This subsection of methodology characterizes testing which was concentrated on measurements of fluid thickness and factors effecting fluid thickness.

2.2.1 Test Sites

Fluid thickness measurements on field aircraft were conducted at Dorval and Mirabel Airports in Montreal, and at the Department of National Defence military base at Winnipeg Airport.

Thickness trials on jet aircraft were conducted in conjunction with full-scale fluid failure tests at Dorval Airport during periods of no precipitation, on Boeing 737 and Fokker 100 aircraft. Trials on turboprop aircraft were conducted to determine the distribution of fluid thickness over the wing and how it was influenced by operation of the propeller. These trials were performed on ATR 42 (at Dorval) and DHC Dash 8 aircraft (at Winnipeg).

Trials on the ATR 42 were planned to be conducted during a window of aircraft ground time from 10:30 to 13:30 each day. This period of availability worked well for the thickness trials, but resulted in several false starts for the fluid failure trials when forecast snow did not occur. Trials at Winnipeg were dependent on forecasts of weather suitable for fluid failure trials. In the single test session conducted, the test crew travelled to Winnipeg on the basis of forecast snow. The forecast snow did not occur and the occasion was used to perform fluid thickness trials.

Further trials on the Boeing 737 (at Mirabel Airport) were conducted to examine the impact of different nozzle designs and consequent spray techniques on fluid application.

For tests conducted at Dorval Airport, teams assembled at the APS test trailer located in the Air Canada ground equipment storage area.

2.2.2 Test Condition/Plan

In every instance, fluid thickness trials were conducted in conditions of no precipitation.

Fluid thickness trials on turbojets were conducted on an opportunity basis while awaiting start of precipitation during fluid failure trials. These thickness trials were meant to supplement similar trials conducted in winter 1995/96 (6), and attention was given to Type IV fluids.

The turboprop trials were designed to assess the influence of propeller wash on fluid thickness on the wing. Both Type I and Type IV fluids were tested. The test plan for trials on propeller aircraft is shown in Table 2.3.

Table 2.4 presents the test plan for assessing the influence of different nozzles and fluid spray techniques on the quality of fluid application. This plan was modified somewhat during the course of the trial.

Table 2.3: Test Plan for Turboprop Aircraft Thickness Tests
NO PRECIPITATION

AIRCRAFT TYPE	RUN #	FLUID TYPE	PROPELLERS ON/OFF
DHC-8	1	1	Off
DHC-8	2	1	On
ATR 42	3	1	Off
ATR 42	4	1	On
ATR 42	5	I/IV	Off/On
ATR 42	6	I/IV	Off/On

Note: This test plan was an advancement on the initial test plan included in Appendix C page C-7.

Conditions Required: Temperature 0 to -10°C
 Winds less than 20 km/hr
 No precipitation, daylight preferred
 Overcast sky preferred

Location: Dorval, Toronto or Winnipeg

Table 2.4: Test Plan for Documenting Fluid Application
Mirabel Airport, April 1997

Run #	Truck & Nozzle #	Application Technique
1	AKRON Nozzle	Standard operator procedure – simulating spray for heavy snow
2	FMC & NEPIRO Nozzle	Standard operator procedure – simulating spray for heavy snow
3	Elephant β Standard nozzle	Standard operator procedure – simulating spray for heavy snow
4	Elephant β Optional nozzle	Lengthy respray to build up maximum fluid thickness
5	FMC & NEPIRO Nozzle	Spray directly downwards on leading edge – to be directed
6	FMC & NEPIRO Nozzle	Spray from forward of leading edge – to be directed

2.2.3 Equipment

Test aircraft were provided by Canadian Airlines International (Boeing 737), American Airlines (Fokker 100), Inter-Canadian (ATR 42), the Department of National Defence (DHC Dash 8), and CanAir Cargo (Boeing 737). Photo 2.3 and Photo 2.18 to Photo 2.21 portray typical test set-ups with various aircraft types, showing spray operations and measurement of thickness in progress.

Octagonal wet film thickness gauges (pictured in Figure 2.6) were used to measure fluid film thickness. These gauges were selected because they provide an adequate range of thicknesses (0.01 mm to 10.2 mm) for Type IV fluids. The other (rectangular) gauge shown in the figure was used in some cases when the fluid film was less thick. The octagonal gauges were mounted on extension poles to extend the operator's reach. As noted in the report on the 1995/96 study (6), the octagonal gauge had to be handled with care as the corners of the gauges used to contact the surface were easily bent. Film thickness is determined by examining the last wetted tooth, and taking the midpoint between the thickness of that tooth and that of the next unwetted tooth. This generated potential reading errors in the range of $\pm 3\%$ to $\pm 14\%$ for most of the values observed.

A special transportable equipment kit was assembled to support tests conducted away from Dorval. This kit included a collapsible flat plate stand with flat plates and all accessory equipment needed to conduct trials. This kit was used successfully during trials at Winnipeg. Photo 2.22 shows the collapsible flat plate stand stabilized by the spare tire of the FOLLOW ME vehicle.

Fluid application trials conducted at Mirabel Airport involved the use of several deicing vehicles and different fluid nozzles. Photo 2.23 portrays the general test set-up at the Mirabel Airport central deicing centre. Fluid application was performed by Aéromag 2000 and one of the deicing vehicles used (Elephant β) is shown in the photo. The various nozzles used in the trials are shown in Photo 2.24 to Photo 2.26.

A complete equipment list for fluid thickness tests may be found in Appendix B, Procedures for Conducting Tests on Jet Aircraft, and Appendix C, Procedure for Conducting Tests on Propeller Aircraft.

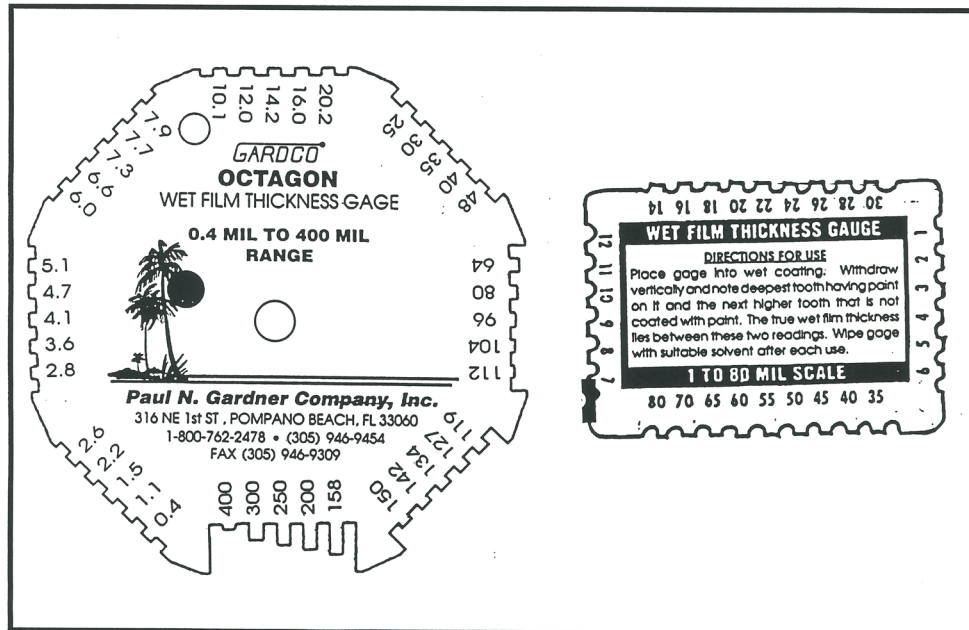


Figure 2.6: Wet Film Thickness Gauges

2.2.4 Test Procedures

Fluid thickness trials were conducted on various types of aircraft, all falling into categories of either jet aircraft or turboprop aircraft.

2.2.4.1 Fluid Thickness Trials on Jet Aircraft

Fluid thickness trials were conducted during the course of fluid failure trials in periods of no precipitation. Measurement locations were selected to enable construction of a profile of fluid thickness over an entire wing chord. To avoid confusion, these points were intentionally identical to points used for collection of fluid samples in the fluid failure trials. Positions were identified on the aircraft wing using a black marker, and the markings were removed at the end of the test session.

Fluid thicknesses were measured four times; twice immediately following fluid application, and again at 10 minutes and 20 minutes following fluid application. Care was taken to avoid any impressions remaining in the fluid surface from the previous placement of the gauge.

Concurrent with aircraft trials, fluid thicknesses were measured on standard flat plates on a stand near the aircraft to provide a basis for reference.

2.2.4.2 *Fluid Thickness Trials on Turboprop Aircraft*

The purpose of these trials was to examine the impact of propeller wash on the thickness of stabilized deicing fluid films on turboprop aircraft wings. These trials were conducted in periods of no precipitation during daylight hours.

The aircraft wing was prepared for testing by marking measurement locations. Locations were selected both inside and outside the propeller wash zone to provide a reference for the effect. The ribbed rubber deicing boot (Photo 2.27) on the leading edge did not offer a good surface for measuring fluid thickness, and some measurement points were relocated to neighbouring metal surfaces.

The influence of propeller wash was examined by first conducting thickness trials without the propeller operating, and then repeating the trial with the propeller operating.

The test fluids were applied to the wing with the propeller static. In the first phase, the engine and propeller remained off, allowing the fluid to stabilize on the wing surface. Fluid thicknesses were measured as in the jet aircraft tests; immediately following spray application, and then after intervals to determine the final stabilized thicknesses.

In the second phase, the engine and propeller were started after the initial fluid thickness measurement was completed and the test team had moved well away from the aircraft. The propeller was run for five minutes at a speed representing a normal taxi operation, and then shut down. Testers then quickly moved stairs to the aircraft wing and measured fluid thickness.

During both phases, fluid thicknesses were measured on standard flat plates on a stand near the aircraft, to provide a reference basis.

2.2.4.3 *Fluid Application Trials*

Fluid application trials were conducted to determine the influence of different spray techniques and different nozzles on the resultant fluid film on the aircraft wing.

In preparation for trials, thickness measurement locations were marked on the CanAir Cargo Boeing 737 aircraft wing. The test area for spray was limited to the middle third of the wing, just outboard of the engine, and measurement points were located in a chord-wise fashion from leading to trailing edge. Points located laterally along the leading edge were also measured.

In each trial, Type IV fluid was applied over Type I fluid. Fluid thickness was measured immediately after application and then at intervals to determine the final thickness. Six trials were performed as follows:

- In three trials, the spray operator was asked to spray following standard procedure, but as if in a heavy snow condition;
- In one trial, the operator was asked to spray repeatedly to build-up a film as thick as possible, to determine the ultimate thickness possible with that nozzle;
- In one trial, the operator was asked to position the nozzle over the wing and spray vertically downwards on the wing surface; and
- In one trial, the nozzle was adjusted to deliver a narrow stream rather than a fan shaped spray pattern.

Fluids applied were Type IV (Union Carbide Ultra +) over heated Type I (Union Carbide XL54).

The applied layer of fluid was examined for consistency of coverage. Video and photographic records of each test were compiled paying special attention to the fluid delivery nozzle and spray technique used, and the resulting fluid film on the wing surface.

2.2.5 Data Forms

The general form for recording fluid thickness measurements on jet aircraft includes a plan form of the wing on which the locations of the measurement points are indicated.

A similar form was used for recording fluid thickness on propeller aircraft. The wing plan, however, shows many more locations for fluid thickness measurement in order to satisfy the specific purpose of this series of tests.

These forms are included in Appendices B and C on pages B-49 and C-23, respectively.

2.2.6 Fluids

Standard strength Union Carbide Type I (XL54) and Type IV (Ultra +) were used for thickness and fluid application tests at Dorval and Mirabel Airports. These fluids were provided by Union Carbide.

Trials on the DHC Dash 8 aircraft, conducted with the Department of National Defence at Winnipeg, employed a Military Type I fluid (designation CGSB3.856 M concentrate deicing fluid). Simultaneous trials on the flat plate stand employed both the Military Type I and Union Carbide XL54 fluids.

2.2.7 Personnel

Spraying was performed by the airline operator's deicing staff, and standard spray procedures were followed, except where noted, for the fluid application trials. In some cases, the deicing was performed by a ground handler on behalf of the airline. Military personnel were involved in the trials conducted at Winnipeg. Tests were coordinated by APS Aviation staff based on forecast weather conditions and data were collected by APS Aviation staff.

Local personnel were hired for tests at Winnipeg to assist a small corps of APS staff in test activities, and to perform video and photographic duties.

Individual task assignments and activity charts are shown in the detailed procedures contained in Appendices B and C.

2.2.8 Analysis Methodology

Manually recorded data were entered from the data sheets onto a Microsoft Excel spreadsheet, and the processed data presented in several graphical formats to provide visual presentation of the fluid film thickness over the wing surface.

This page intentionally left blank.

Photo 2.1: Canadian Airlines International Boeing 737



Photo 2.2: American Airlines Fokker 100



Photo 2.3: Inter-Canadian ATR 42



Photo 2.4: Department of National Defence DHC Dash 8



Photo 2.5: American Airlines Deicing Vehicle Applying Fluid on a Fokker 100



Photo 2.6: Air Canada Deicing Control Centre at East Pad



Photo 2.7: APS Trailer at Dorval Airport



Photo 2.8: Inside of APS Trailer at Dorval



Photo 2.9: Precipitation Rate Measurement Equipment

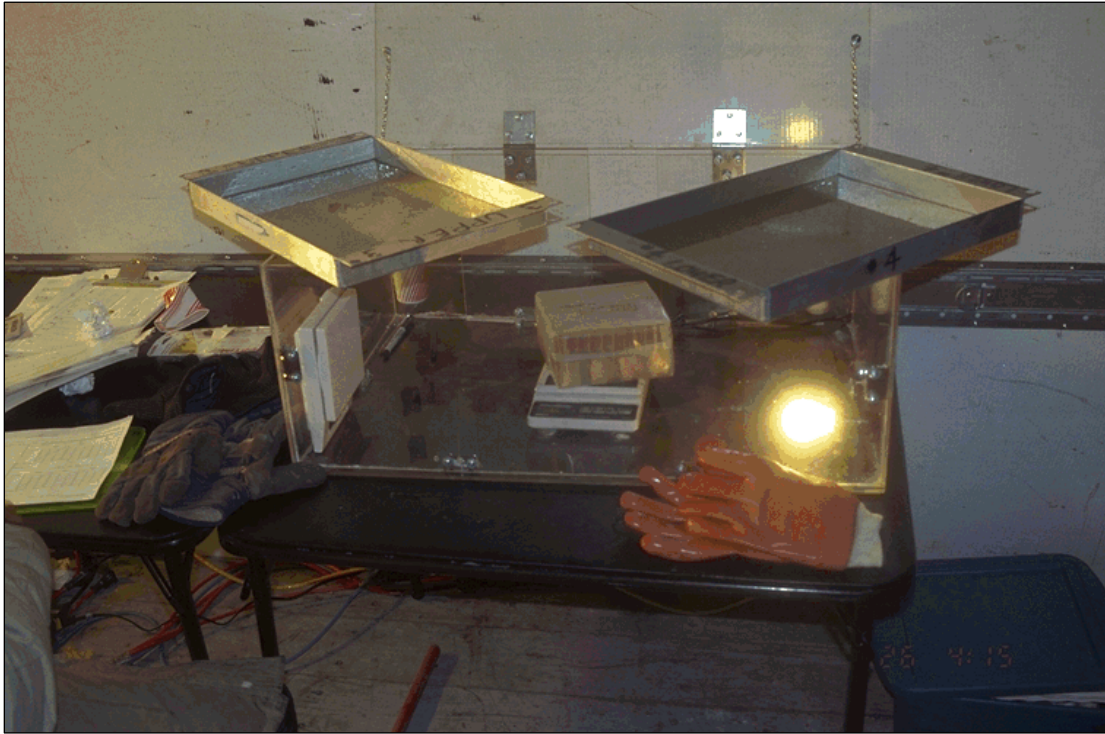


Photo 2.10: Field Lab for Full-Scale Tests



Photo 2.11: Rolling Stairs and Step Ladders Positioned Around Aircraft



Photo 2.12: Mast Lighting Used for Aircraft Illumination



Photo 2.13: Fluid Sampling Location on Fokker 100 Wing



Photo 2.14: Collecting Samples of Fluid on Wing Surface



Photo 2.15: Portable Sampling Container Kit



Photo 2.16: Misco Refractometer Used to Measure Freeze Point of Samples



Photo 2.17: Hand-Held Ice Detection Sensor by RSVI ID-1H

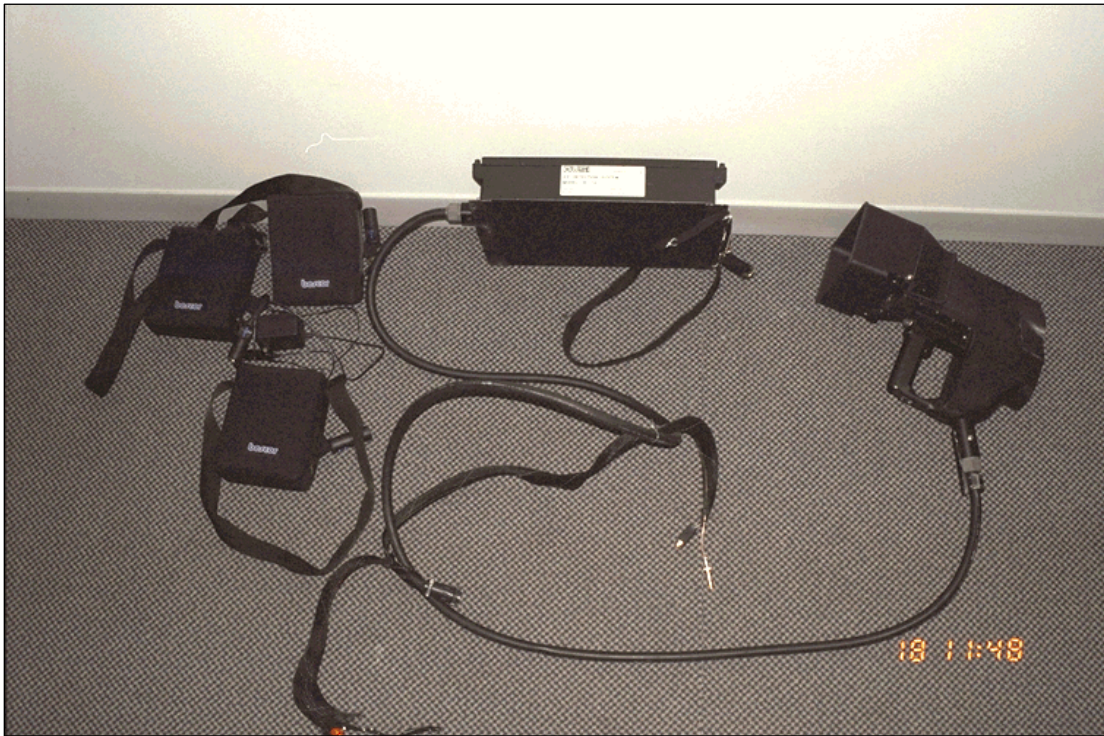


Photo 2.18: Measurement of Fluid Thickness



Photo 2.19: Spray Application with Task Force Tips Nozzle



Photo 2.20: Spray Application with Wand



Photo 2.21: Test Set-up – ATR 42 Aircraft



Photo 2.22: Portable Flat Plate Stand



Photo 2.23: Test Set-up at Mirabel Airport Deicing Centre



Photo 2.24: Nepiro Type II Nozzle



Photo 2.25: Akron Type I Nozzle



Photo 2.26: Elephant B Standard and Optional Nozzle



Photo 2.27: ATR 42 Wing – Ribbed Deicing Boot



3. DESCRIPTION AND PROCESSING OF DATA

Section 3 provides descriptions of the raw data and also describes the procedures used to process the data from fluid failure tests (Subsection 3.1) and fluid thickness tests (Subsection 3.2).

3.1 Fluid Failure Characteristics

This subsection will discuss the processing of data as it relates to fluid failure tests which were conducted.

3.1.1 Overview of Test Sessions

Table 3.1 provides a summary of all the aircraft fluid failure tests performed during the 1996/97 test season. Operational summaries of each test session were completed with observations relating to general events, test conditions and problems. This summary appears in Appendix G. A general summary of the full-scale tests conducted appears in Figure 3.1.

A dry run was held on December 12/13, 1996, to train personnel and evaluate test procedures, but because no precipitation was present, no usable data were gathered.

Tests were planned for the night of January 9/10, 1997, on an American Airlines Fokker 100. The ground handler, AMR services, was unable to tow the aircraft to the deicing pad due to heavier than forecast snow accumulation on the ramp. Attempts were made to have the snow cleared, with no success, and as a result, the test session was cancelled at 02:30.

Tests ID # 1 to ID # 4 were conducted during the night of January 15/16, 1997, on a Canadian Airlines International Boeing 737. Snow only began to fall after 04:00, despite forecasts for between 5 and 10 cm between midnight and 05:00.

Tests ID # 5 to ID # 8 were performed during the night of January 21/22, 1997, on a Canadian Airlines International Boeing 737. Due to the late arrival of the forecast precipitation, the first test of the night did not begin until 03:54. Precipitation was a combination of snow and ice pellets, and as a result failures were not easy to detect. The Type IV fluid used in ID # 7 was unusually thin and pale. Samples were taken from the truck and sent to Union Carbide for analysis.

Tests ID # 9 to ID # 12 were performed at night on January 24/25, 1997, on a Canadian Airlines International Boeing 737. Prior to testing, APS Aviation was advised that the Type IV fluid used during the last test session was old Ultra, and

the fluid viscosity was severely degraded due to numerous heating and cooling cycles. The late delivery of the new fluid (Ultra +) delayed the first test of the evening until 02:30.

Tests ID # 13 to ID # 17 were performed at night on January 27/28, 1997, on a Canadian Airlines International Boeing 737. The aircraft arrived at the deicing pad at 01:15. Testing began shortly thereafter.

Tests ID # 18 to ID # 23 were performed at night on February 4/5, 1997, on an American Airlines Fokker 100. Problems were encountered with one of the lights used for testing when the ballast burned out. Since no spare had been provided, the light remained inoperative for the rest of the test session, and small spotlights were attached to the ladders for the duration of the tests.

Tests ID # 24 to ID # 28 were performed at night on February 20/21, 1997, on a Canadian Airlines International Boeing 737. Freezing rain began at 01:45 and continued until 04:00, when the precipitation turned to rain.

Turboprop tests were planned for February 26 and 27, 1997, on an Inter-Canadian ATR 42. The tests were cancelled on the first occasion since there was no precipitation. On the second occasion, tests were cancelled when the precipitation fell in the form of rain. In both cases, costs were incurred for truck rental, airport escort and preparation time. Another turboprop test session was planned for March 4, 1997, on an Inter-Canadian ATR 42. The tests were cancelled because precipitation started five hours later than expected.

Tests ID # 29 to ID # 35 were performed at night on March 5/6, 1997, on an American Airlines Fokker 100. The aircraft arrived just prior to 01:30 and tests continued until 04:45.

Several unsuccessful attempts were made to arrange for testing of a DeHavilland Dash 8 aircraft in Toronto. Tests were planned for March 8, 1997, on a Department of National Defence DHC Dash 8 in Winnipeg. When no precipitation occurred, thickness tests were performed on the aircraft. A more complete overview of this test session is described in Appendix G.

Tests ID # 36 to ID # 38 were performed on March 14, 1997, on an Inter-Canadian ATR 42. Failures progressed very rapidly (due in large part to the high rates of precipitation) and in two tests, the wings had failed prior to the initial inspection of the wing following shutdown of the engine.

Attempts were made to gain access to a Canadair Regional Jet from several sources, including Comair, Canadair, and Air Canada. All attempts to secure a Regional Jet were unsuccessful, which was unfortunate since a good deal of time and effort was expended in developing plans for testing a Regional Jet.

3. DESCRIPTION AND PROCESSING OF DATA

Table 3.1: Listing of Aircraft Fluid Failure Tests Conducted in 1996/97

ID #	Test Location	date	run no.	AIRLINE	A/C Type	A/C Wing	fluid name	Fluid Quantity (L)	APS Air Temp (°C)	HOT End Precip. Rate (g/dm ² /hr)	Calculated wind Head/Tail/ Cross Up/Downwind	Calculated wind Head/Tail/ Up/Downwind	APS Wind direct. (deg.)	APS Wind Speed (kph)	HOT Start Time	HOT End Time	Plate Start Time	a/c Orient. (E of N) (deg.)	wing fail (min)	wing 10% fail (min)	wing 25% fail (min)	Plate 1 fail XL54 (min)	Plate 2 fail XL54 (min)	Plate 1 Ultra+ (min)	Plate 2 Ultra+ (min)	Wing Rate first g/dm ² hr	Wing Rate 10% g/dm ² hr	Wing Rate 25% g/dm ² hr	Plate 1 rate g/dm ² hr	Plate 2 rate g/dm ² hr	% fail LE at 10%	X-Wind Related Tests	Thickness 6 Pts. Measured	Precip. Type	Comments	
1	YUL	Jan-16-97	1	Canadian	B-737	Strbd	XL54	50	-0.2	6.6	cross	upwind	182	14	4:07	4:53	4:07	55	36	43	45	41	41			2.2	5.5	6.3	4.7	4.7	100				S	
2	YUL	Jan-16-97	2	Canadian	B-737	Port	XL54	60	-0.3	9.4	cross	downwind	183	13	4:14	4:57	4:15	55	30	33	35	33	33			3.3	5.1	6.1	5.8	5.8	50				S	
3	YUL	Jan-16-97	3	Canadian	B-737	Strbd	XL54	60	-1.2	7.2	cross	upwind	173	11	5:14	5:26	5:14	55	8	12	N/F	N/F	N/F			9.2	6.9				50	X			S	
4	YUL	Jan-16-97	4	Canadian	B-737	Port	XL54	60	-1.1	6.3	cross	downwind	175	11	5:16	5:29	5:16	55	8	N/F	N/F	N/F	N/F			7.1					N/F	X			S	test stopped
5	YUL	Jan-22-97	1	Canadian	B-737	Port	XL54	50	-8.3	7.1	cross	downwind	38	10	3:54	4:03	3:54	270	4	6	7	12	10			5.6	5.6	5.6	8.0	7.4	80				IP/S	
6	YUL	Jan-22-97	2	Canadian	B-737	Strbd	XL54	65	-8.3	9.6	cross	upwind	37	9	4:01	4:12	4:02	270	7	7	8	10			10.4	10.4	10.2	9.5		20				IP/S		
7	YUL	Jan-22-97	3	Canadian	B-737	Port	Ultra/XL54	55/150	-8.6	25.6	cross	downwind	40	9	4:30	4:54	4:31	270	10	17	18			26	26	19.8	24.9	24.9	28.6	28.6	40				IP/S	not-usable
8	YUL	Jan-22-97	4	Canadian	B-737	Strbd	XL54	150	-8.7	25.7	cross	upwind	41	9	4:38	4:46	4:38	270	3	5	6	4	4			19.2	27.8	29.5	25.6	25.6	40				IP/S	
9	YUL	Jan-25-97	1	Canadian	B-737	Port	XL54	25	-1.6	11.3	cross	upwind	135	18	2:30	2:48	2:31	240	10	14	15	N/F	N/F			10.5	9.2	9.2			40	X			S	
10	YUL	Jan-25-97	2	Canadian	B-737	Strbd	XL54	40	-1.7	12.7	cross	downwind	137	18	2:35	2:50	2:35	240	3	3	3	N/F	N/F			11.2	11.2	11.2			0	X			IP	test stopped
11	YUL	Jan-25-97	4	Canadian	B-737	Strbd	Ultra+/XL54	75/100	-0.3	1.2	cross	downwind	138	15	3:53	N/A	3:56	240	N/F	N/F	N/F	N/F	N/F										N/F		N/A	not-usable
13	YUL	Jan-28-97	1	Canadian	B-737	Port	Ultra+/XL54	85/250	-4.3	18.2	tail	tail	163	11	1:54	4:30	1:52	310	36	101	126			39	48	20.9	14.1	17.1	20.9	20.0	25				S	
14	YUL	Jan-28-97	2	Canadian	B-737	Strbd	XL54	275	-4.9	20.8	tail	tail	156	11	2:06	2:21	2:05	310	4	6	7	7	5			20.8	20.9	21.1	20.9	20.8	25				S	
15	YUL	Jan-28-97	3	Canadian	B-737	Strbd	XL54	75	-4.5	12.3	tail	tail	155	11	2:39	3:02	2:41	310	6	9	14	10	10			12.0	11.3	11.4	10.9	10.9	20				S	
16	YUL	Jan-28-97	4	Canadian	B-737	Strbd	XL54	150	-4.0	29.9	tail	tail	171	11	3:32	3:46	3:32	310	4	7	10	7	8			12.8	24.0	30.3	24.0	26.8	35				S	
17	YUL	Jan-28-97	5	Canadian	B-737	Strbd	Ultra+/XL54	110/150	-3.6	13.5	tail	tail	167	10	4:09	5:00	4:11	310	20	51	N/F			56	59	17.3	13.0		13.4	13.1	40				S	
18	YUL	Feb-05-97	1	American	F100	Strbd	Ultra+/XL54	55/360	-2.2	18.5	tail	tail	96	7	1:38	2:38	1:39	275	25	42	52			58	59	13.9	14.8	16.4	18.2	18.5	10				S	bad application
19	YUL	Feb-05-97	2	American	F100	Port	Ultra+/XL54	115/180	-1.9	17.2	tail	tail	101	7	2:14	3:57	2:15	275	7	31	51			37	45	21.1	22.4	21.5	22.9	22.9	10				S	
20	YUL	Feb-05-97	3	American	F100	Strbd	XL54	115	-1.9	16.8	tail	tail	97	7	2:51	3:08	2:53	275	5	9	12	5	6			23.2	23.2	20.1	23.2	23.2	0				S	
21	YUL	Feb-05-97	4	American	F100	Strbd	XL54	115	-1.6	19.6	tail	tail	109	9	3:40	3:54	3:41	275	6	7	9	6	7			16.7	16.9	17.2	17.6	17.6	0				S	
22	YUL	Feb-05-97	5	American	F100	Port	XL54	135	-1.4	14.4	tail	tail	108	9	4:18	4:45	4:20	275	8	9	10	7			15.2	15.1	15.1	14.4		0				S		
23	YUL	Feb-05-97	6	American	F100	Strbd	XL54	135	-1.4	13.6	tail	tail	105	9	4:23	4:39	4:23	275	6	8	10	6			14.4	15.7	16.4	14.4		0				S		
24	YUL	Feb-21-97	1	Canadian	B-737	Strbd	Ultra+/XL54	50/100	-3.2	20.9	calm wind	calm wind	37	6	1:45	3:04	1:45	50	15	40	60			42		10.0	16.1	20.7	16.8		40			X	LFZR	
25	YUL	Feb-21-97	2	Canadian	B-737	Port	XL54	100	-3.5	17.1	calm wind	calm wind	33	6	1:53	2:23	1:54	50	8	13	18	8	8			12.8	14.1	15.0	14.0	14.0	80			X	LFZR	
26	YUL	Feb-21-97	3	Canadian	B-737	Port	XL54		-2.3	24.7	calm wind	calm wind	54	4	2:37	3:20	2:37	50	12	17	29	6	6			30.4	30.4	24.6	30.4	30.4	70				LFZR	
27	YUL	Feb-21-97	4	Canadian	B-737	Strbd	Ultra+/XL54	65/100	-0.3	24.0	calm wind	calm wind	110	2	3:13	N/F	3:15	50	N/F	N/F	N/F											N/F		X	LFZR	not-usable
28	YUL	Feb-21-97	5	Canadian	B-737	Port	XL54	120	0.5	22.4	calm wind	calm wind	144	3	3:48	N/F	3:49	50	N/F	N/F	N/F										N/F		LFZR	not-usable		
29	YUL	Mar-06-97	1	American	F100	Strbd	Ultra+/XL54	135/115	-3.8	8.2	head	head	50	17	1:30	2:58	1:30	50	27	73	88			89	101	6.4	8.0	8.0	8.0	8.7	5			X	S	bad application
30	YUL	Mar-06-97	2	American	F100	Port	XL54	115	-3.2	8.0	head	head	52	16	1:41	2:05	1:42	50	9	10	12	15	16			4.0	4.0	4.9	7.2	7.2	5				S	
31	YUL	Mar-06-97	3	American	F100	Port	XL54	115	-3.8	6.1	head	head	49	17	2:18	2:51	2:19	50	6	9	14	9	9			9.6	9.2	8.4	8.9	8.9	10				S	
32	YUL	Mar-06-97	4	American	F100	Port	XL54	135	-4.1	16.4	cross	downwind	51	20	3:24	3:36	3:25	310	3	4	6	7	7			20.0	17.6	16.4	15.2	15.2	2	X			S	
33	YUL	Mar-06-97	5	American	F100	Strbd	XL54	180	-4.2	15.5	cross	upwind	51	20	3:27	3:43	3:27	310	9	10	11	7	7			15.9	16.1	16.3	15.2	15.2	5	X			S	
34	YUL	Mar-06-97	6	American	F100	Port	Ultra+/XL54	135/135	-4.7	32.7	cross	downwind	52	20	3:52	4:27	3:54	310	10	18	23			28	36	21.3	25.7	29.5	33.2	36.0	20	X	X	S	S	bad application
35	YUL	Mar-06-97	7	American	F100	Strbd	Ultra+/XL54	135/135	-4.7	34.6	cross	upwind	51	20	3:59	4:45	3:58	310	13	36	41			33	34	31.6	38.4	38.0	37.9	37.9	20	X	X	S	S	
36	YUL	Mar-14-97	1	Inter-Canadian	ATR 42	Port	XL54	200	-12.3	33.9	head	head	61	13	11:36	12:12	11:36	60	7	9	24	9			30.6	30.6	32.3	30.6						S		
37	YUL	Mar-14-97	2	Inter-Canadian	ATR 42	Port	XL54	200	-12.4	44.5	cross	downwind	61	13	12:17	12:26	12:18	330	6	7	8	8			44.3	44.4	44.4	44.5						S		
38	YUL	Mar-14-97	3	Inter-Canadian	ATR 42	Strbd	XL54	246	-12.5	48.2	cross	upwind	62	13	12:20	12:40	12:20	330	5	5	6	7			44.5	44.5	44.6	44.6						S		
39	YUL	Dec-13-96	1	American	F100		Ultra+	70	-11.0		head	head	40					40																		dry run
40	YUL	Dec-13-96	2	American	F100		Ultra+/XL54	135/70	-11.0		head	head	40					40																		dry run

- ID # 7 was conducted using degraded Ultra (a-303).
- ID # 11 moved to thickness log.
- Shaded ID numbers are unusable tests.

□ A total of 33 usable tests were conducted on eight occasions.

<u>Date</u>	<u># of tests</u>	<u>Airline/ Aircraft</u>	<u>Precipitation Type</u>	<u>Average Temperature</u>
Jan 16, 1997	4	CAI B-737	S	-1°C
Jan 22, 1997	3	CAI B-737	S/IP	-9°C
Jan 25, 1997	2	CAI B-737	S	-1°C
Jan 28, 1997	5	CAI B-737	S	-5°C
Feb 5, 1997	6	AA F100	S	-2°C
Feb 21, 1997	3	CAI B-737	ZR	-2°C
Mar 6, 1997	7	AA F100	S	-4°C
Mar 14, 1997	3	Inter-Canadian ATR 42	S	-12°C

□ Almost 1000 fluid samples were collected by APS and several were collected by Optima.

Figure 3.1: General Summary of Fluid Failure Tests Conducted

3.1.2 Breakdown of Test Variables

A total of 40 aircraft full-scale tests were initiated at Dorval Airport on nine different occasions including the dry run session. Of this total, 33 were usable. The breakdown of the tests conducted is all follows:

	# of Tests
Usable	33
Dry Runs	2 (ID # 39, 40)
Not Usable	4 (ID # 7, 12, 27, 28)
Thickness Test (transferred to thickness log)	1 (ID # 11)
TOTAL	40

The general summary of usable tests conducted by aircraft type, fluid type and wind direction is shown in Figure 3.2. The breakdown of usable tests as a function of aircraft type was as follows:

	# of Tests
Fokker 100	13
Boeing 737	17
ATR 42	3
TOTAL	33

The breakdown of usable tests as a function of fluid type was as follows:

	# of Tests
Type I fluid	25
Type IV fluid	8
TOTAL	33

The breakdown of usable tests as a function of wind direction was as follows:

	# of Tests
Headwind	4
Tailwind	11
Crosswind (Upwind)	8
Crosswind (Downwind)	7
Calm wind	3
TOTAL	33

The breakdown of usable tests as a function of precipitation type was as follows:

	# of Tests
Snow	25
Ice pellets/Snow	5
Light freezing rain	3
TOTAL	33

Several other variables affected the results of the usable full-scale tests conducted in 1996/97. The average rates of precipitation for usable tests ranged from 6.1 g/dm²/hr to 48.2 g/dm²/hr. Average wind speeds varied between 4 kph and 20 kph. Test temperatures were between -0.2°C and -8.7°C for turbofan tests. The turboprop tests were conducted at -12.5°C and the rates for these tests were abnormally high – just under 50 g/dm²/hr.

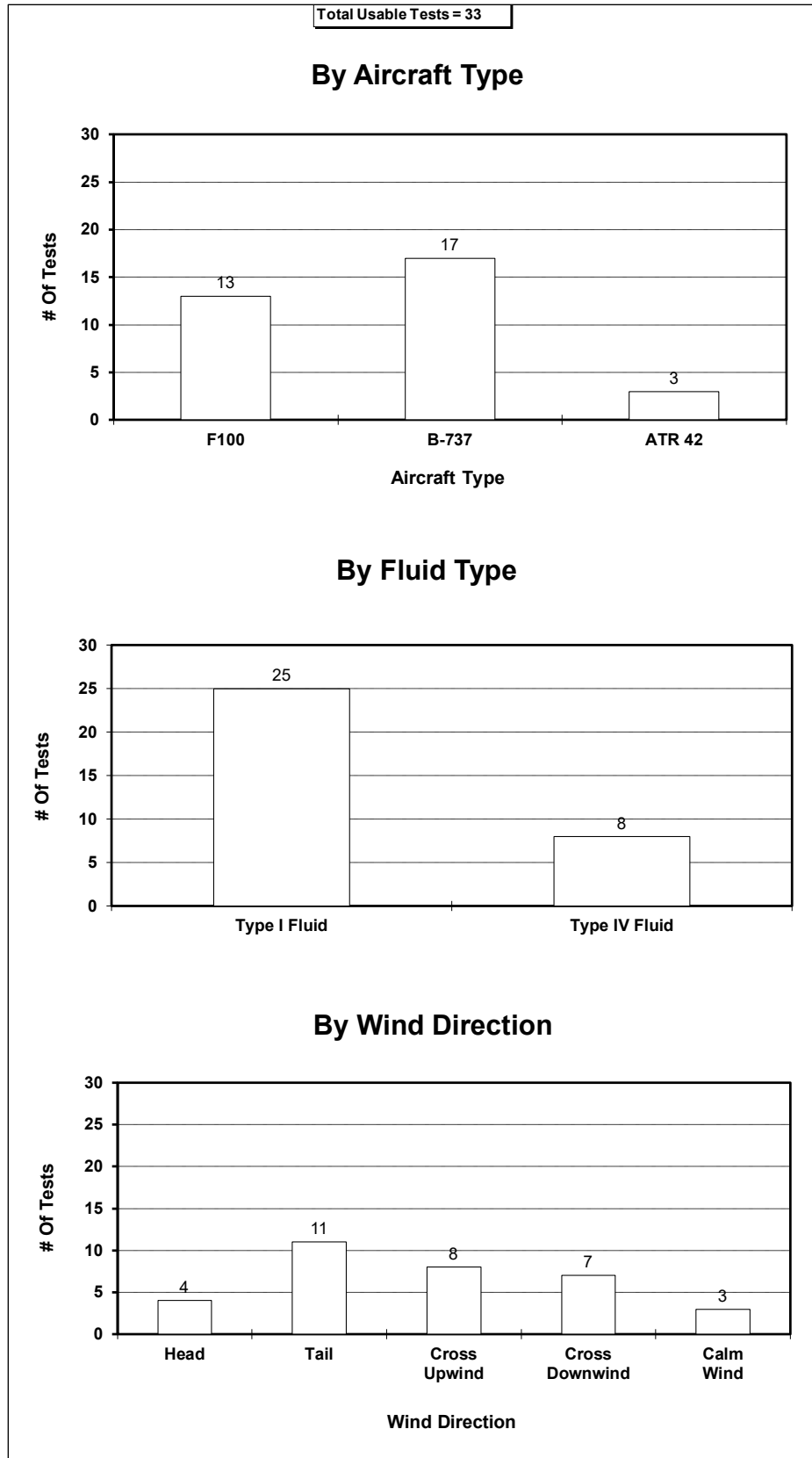


Figure 3.2: General Summary of Fluid Failure Tests Conducted

3.1.3 Description and Reduction of Data Collected

A complete detailed compilation and reduction of the raw data was conducted at the end of the tests. This database, contained in a separate working document, was not included as part of this report due to its volume.

This section provides an example of the raw data collected for a typical test. A description and examples to illustrate how the data were analysed are also included as well as the results of analyses.

3.1.3.1 General test information sheet (Figure 3.3)

This sheet gives all the pertinent data needed to understand the graphs and figures accompanying it:

ID #:	Exclusive number identifying each test;
Date/Run:	The date on which each test was run; / The test number for each date;
Airline/Aircraft type:	The airline involved in the testing; / The type of aircraft being tested;
Wing used:	Starboard or port wing used for test;
Airport:	The test location;
Outside air temp.:	The average outside ambient temperature for each test measured in degrees centigrade;
Wing orientation:	Crosswind, headwind, tailwind, calmwind;
Wind direction:	The average direction in which the wind is blowing for the test duration measured in degrees. Zero degrees represents Magnetic North;
Wind speed:	Average wind speed for the duration of each test measured in kilometres per hour;
Precipitation type:	The classification of precipitation;
Aircraft direction:	The direction in which the nose of the aircraft is pointing, measured in degrees. Zero degrees represents Magnetic North;
Holdover time start:	The time at which the test started, as determined by the moment at which spraying of fluid (last step) was started;
Type I fluid:	The Type I fluid being used for the test; and
Type IV fluid:	The Type IV fluid being used for the test.

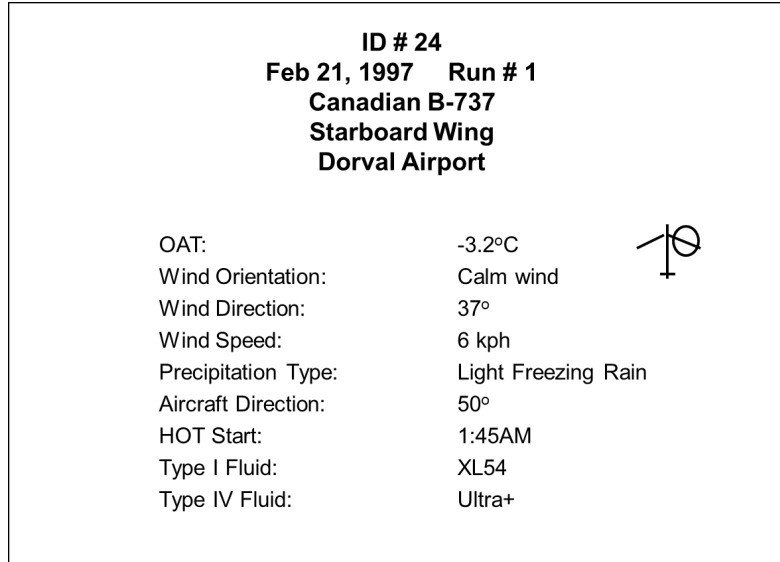


Figure 3.3: General Test Information

3.1.3.2 Percentage of Fluid Failure by Wing Section Versus Time (Figure 3.4)

This graph shows how failure progresses over time for each test. The wing was divided into nine sections, as depicted in Figure 3.5. The percentage of each section that has failed is obtained from the failure contours. These are then plotted on Figure 3.4, where percentage failed represents the percentage of the section that has failed at the time that the contour was drawn. The following symbols were used for designating each section of the wing:

- | | | | |
|-----|------------------------|-----|-------------------|
| LI: | Leading Inner Section | MI: | Mid Inner Section |
| LM: | Leading Mid-Section | MM: | Mid Mid-Section |
| LO: | Leading Outer Section | MO: | Mid Outer Section |
| TI: | Trailing Inner Section | | |
| TM: | Trailing Mid-Section | | |
| TO: | Trailing Outer Section | | |

From Figure 3.4, it can be observed that initial failure and 25% failure was first experienced in the trailing outer section, and in particular on the aileron within this section. However, 100% failure was first observed on the leading mid-section. This figure also shows that the mid-sections are the last sections to undergo initial failure and also the last sections to reach 25% failure. The mid-sections never reached 100% failure. These observations are consistent with charted failure patterns discussed later.

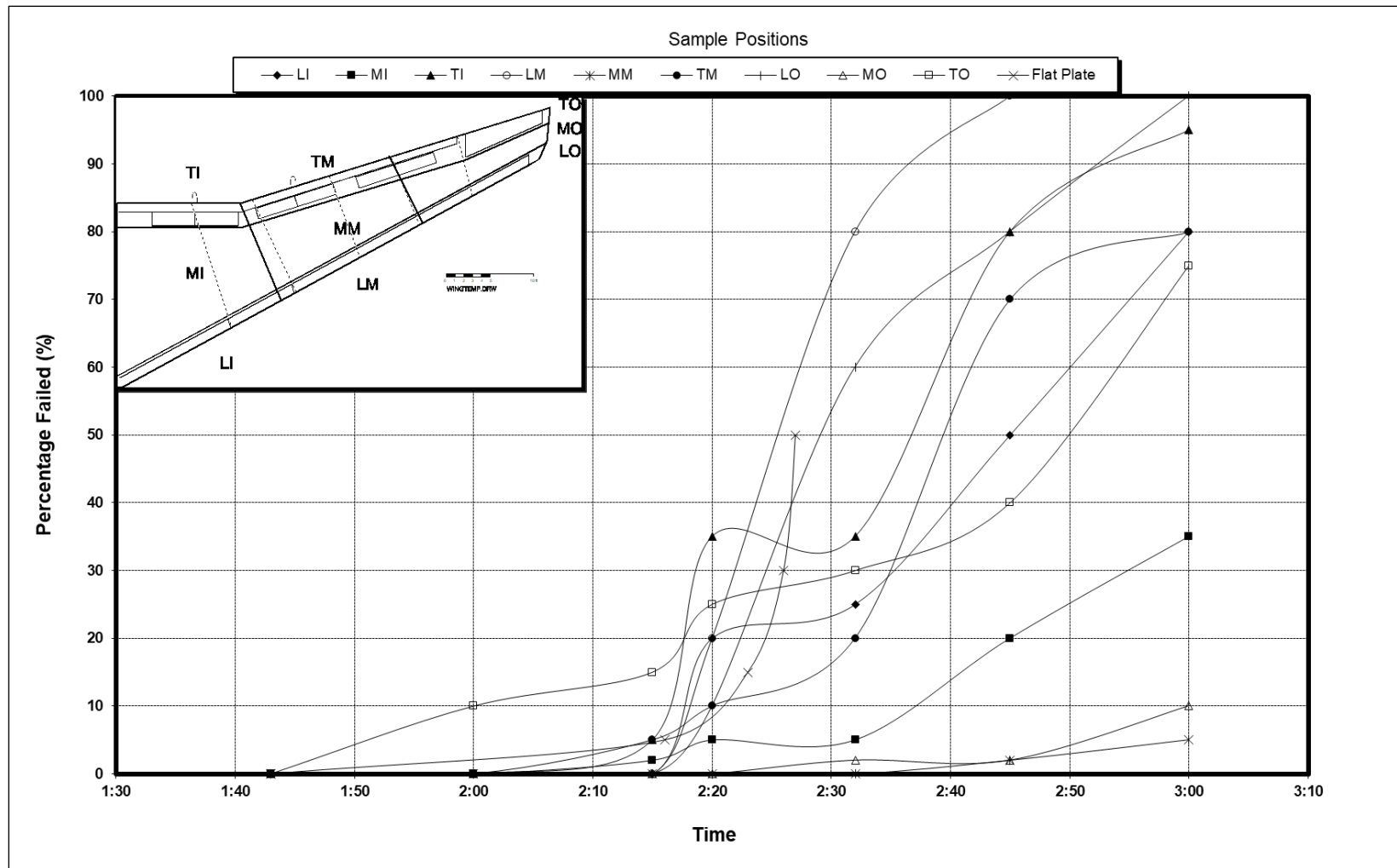
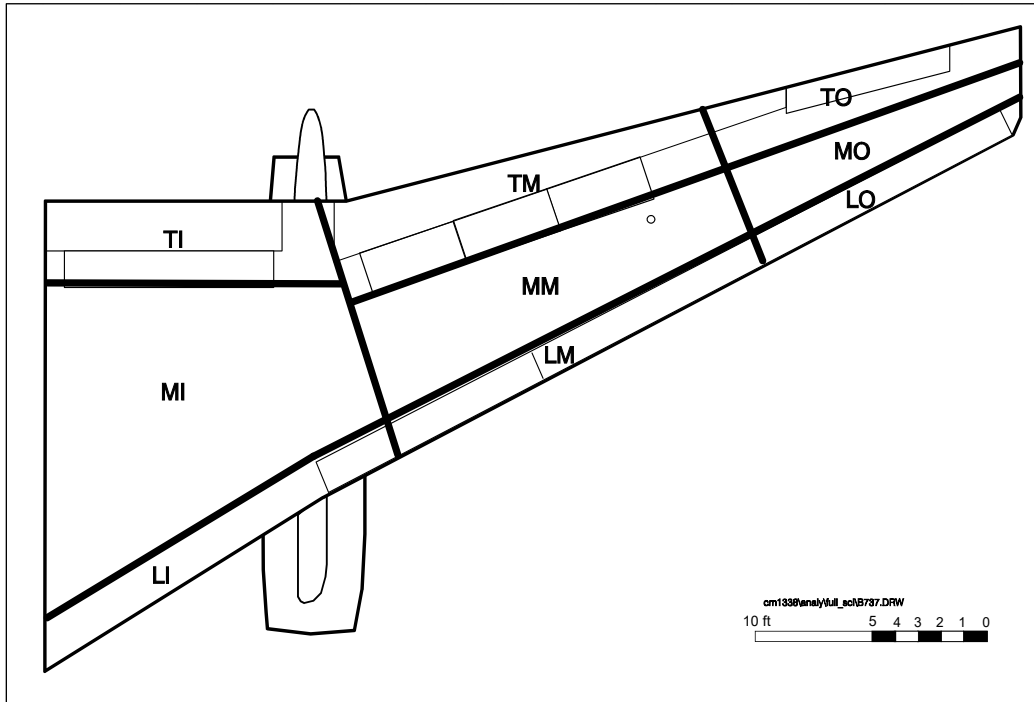


Figure 3.4: Percentage of Fluid Failure by Wing Section vs Time

ID 24

BOEING 737



FOKKER 100

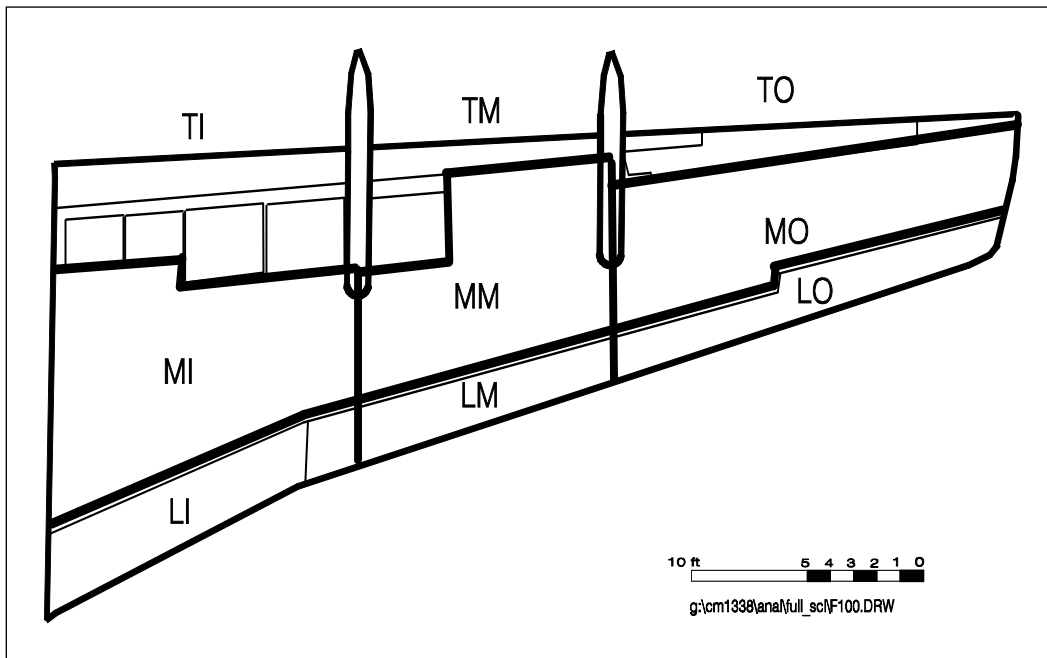


Figure 3.5: Sub-Division of Wing

3.1.3.3 Brix Measurements (Figure 3.6)

Fluid samples were taken at each sample position at the predetermined time intervals specified in the test procedure. Brix values were determined from these fluid samples using a Misco Brixometer and the values were transposed onto a plan view of the wing. For ID # 24, fluid samples were collected at three different time intervals for each wing position.

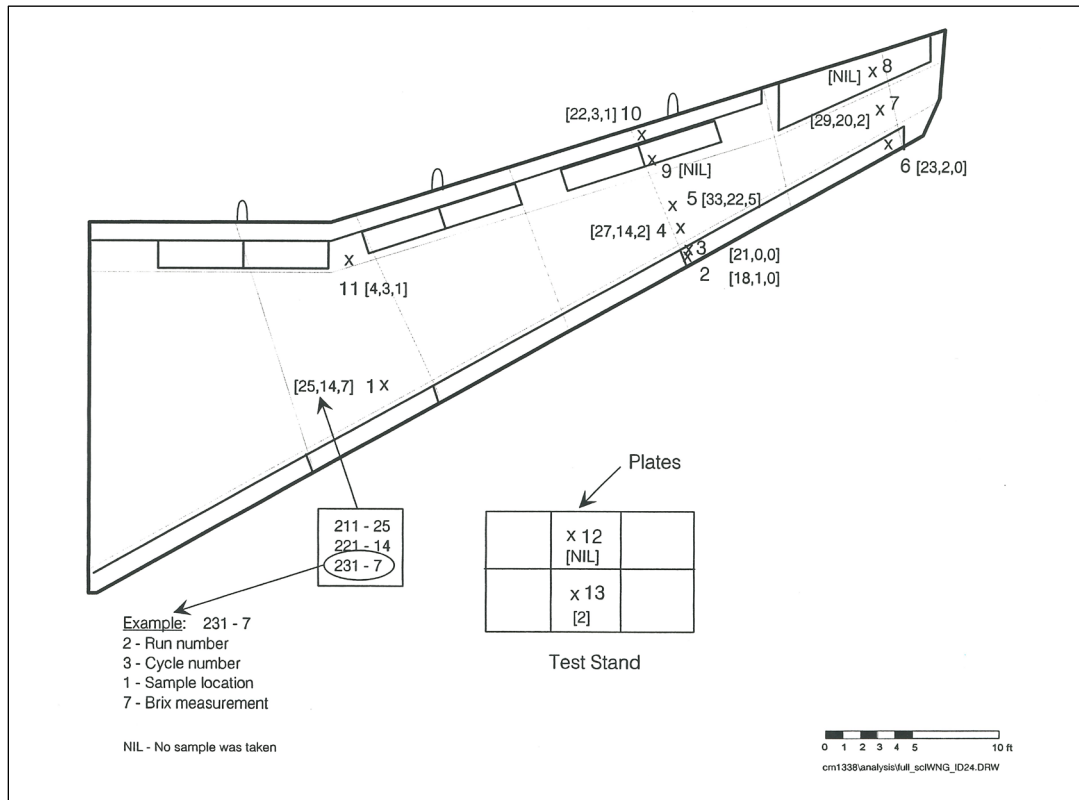


Figure 3.6: Brix Measurements for ID # 24

3.1.3.4 Brix Versus Time (Figure 3.7)

This graph shows how the Brix (fluid freeze point) changes as a function of time. The fluid sample locations are shown (same as in Figure 3.6). The Brix values were plotted for each sampling location versus the time at which the samples were collected.

From Figure 3.7, sample locations 5 and 7 are observed to maintain the highest Brix readings. This observation is consistent with Figure 3.4, as these locations are within the mid-sections which are the last to fail. Sample location 11 has the lowest Brix reading, which is also consistent with Figure 3.4, since sample location 11 falls within the trailing inner section which was among the first areas to fail.

3.1.3.5 Fluid Thickness on Wing Versus Time (Figure 3.8)

This graph shows how the thickness of the fluid on the wing behaves as it settles and is diluted by precipitation over time. Thickness measurements were taken at sample locations 3, 4 and 10 at the beginning of the test and also whenever samples for Brix measurements were collected.

Sometimes, fluid thickness measurements could not be taken due to accumulation of snow at the fluid sampling locations.

The thickness measurements were then plotted versus time where thickness represents the fluid thickness value, and time represents the time when the measurements were made. Fluid thickness measurements were collected as described in Subsection 2.2.3.

From Figure 3.8, the expected decrease in fluid thickness with time is observed. The rate of decrease in thickness is markedly greater than that measured during thickness tests in dry conditions, and is strongly influenced by fluid dilution.

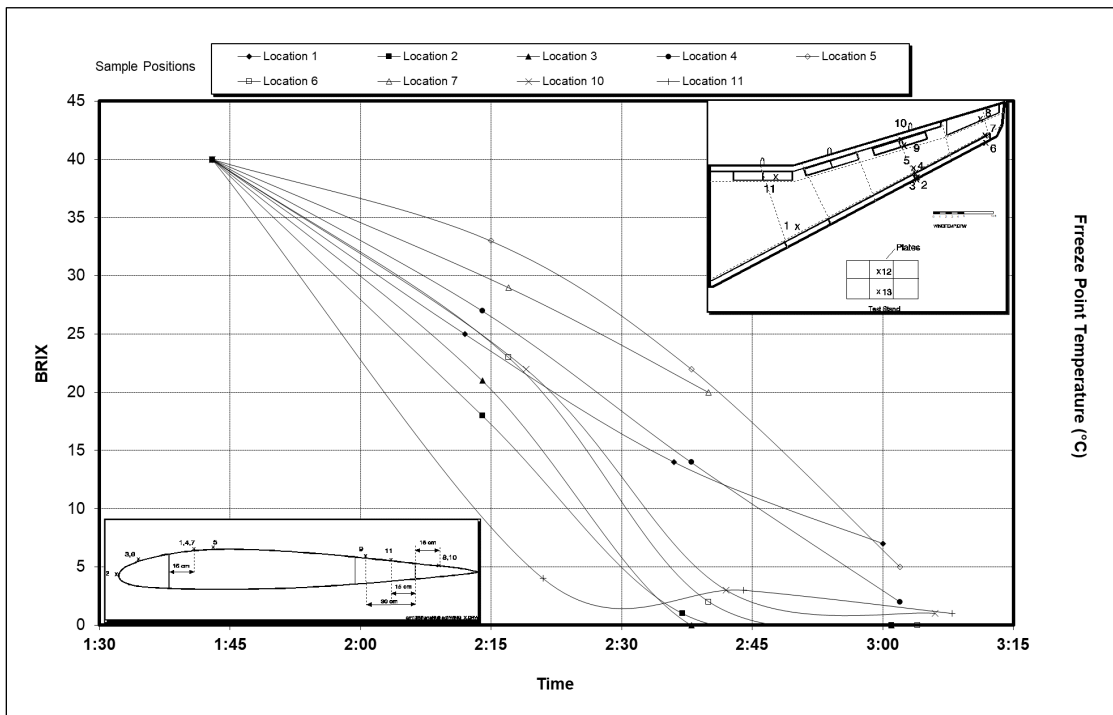


Figure 3.7: Brix vs Time, ID # 24

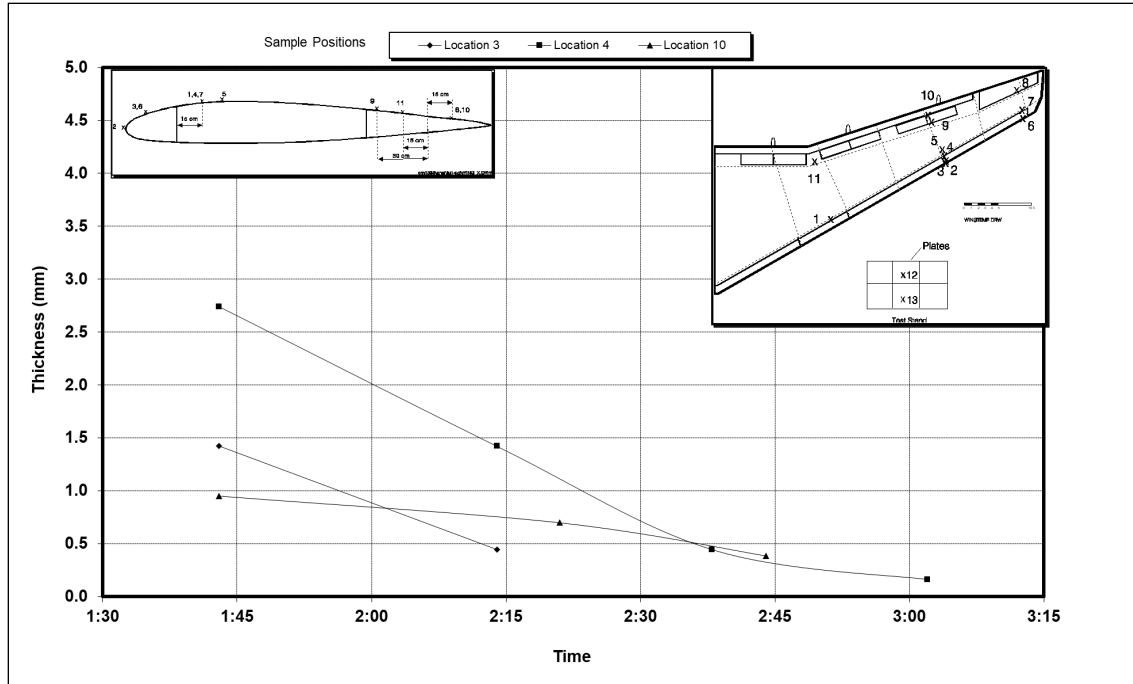


Figure 3.8: Film Thickness on Wing vs Time, ID # 24

3.1.3.6 Precipitation Rate Versus Time (Figure 3.9)

This graph shows how the precipitation rate changed over the test period. Plate pans were placed on a stand near the aircraft. These pans were weighted regularly after periods of time (usually five minutes) and from this, the plate pan rate was calculated in $\text{g}/\text{dm}^2/\text{hr}$. This was then plotted where plate pan rate of precipitation represents the average rate of precipitation in $\text{g}/\text{dm}^2/\text{hr}$ and time represents the time over which the average measurement was taken.

3.1.3.7 Temperature Versus Time (Figure 3.10)

This graph shows how the outside air temperature changed with respect to time during the test period. These data were obtained from a digital thermometer mounted at the APS test site and interfaced to a personal computer which was used to capture the record.

3.1.3.8 Wind Direction Versus Time (Figure 3.11)

This graph shows how wind direction changed with respect to time during the test period. These data were obtained from instruments located at the APS test site. Wind direction represents the direction the wind is blowing measured in degrees and zero degrees corresponds to Magnetic North.

3.1.3.9 Wind Speed Versus Time (Figure 3.12)

This graph shows how the wind speed changes with respect to time. These data are obtained from instruments located at the APS test site. Wind speed represents the speed at which the wind is blowing three metres above the ground, in kph.

3.1.3.10 Mapping of Fluid Failure to Illustrate Progression

Failures were mapped onto a plan view of wings at various intervals over the duration of the tests. An electronic representation of the hand-drawn patterns is shown in Figure 3.13 for ID # 24 on a Boeing 737. Initial failure was detected 17 minutes after fluid application, and progressive failure patterns were redrawn again 32, 37, 49, 62 and 77 minutes after fluid application. Similarly, an electronic representation of the hand-drawn failure patterns on a Fokker 100 (ID # 31), is provided in Figure 3.14.

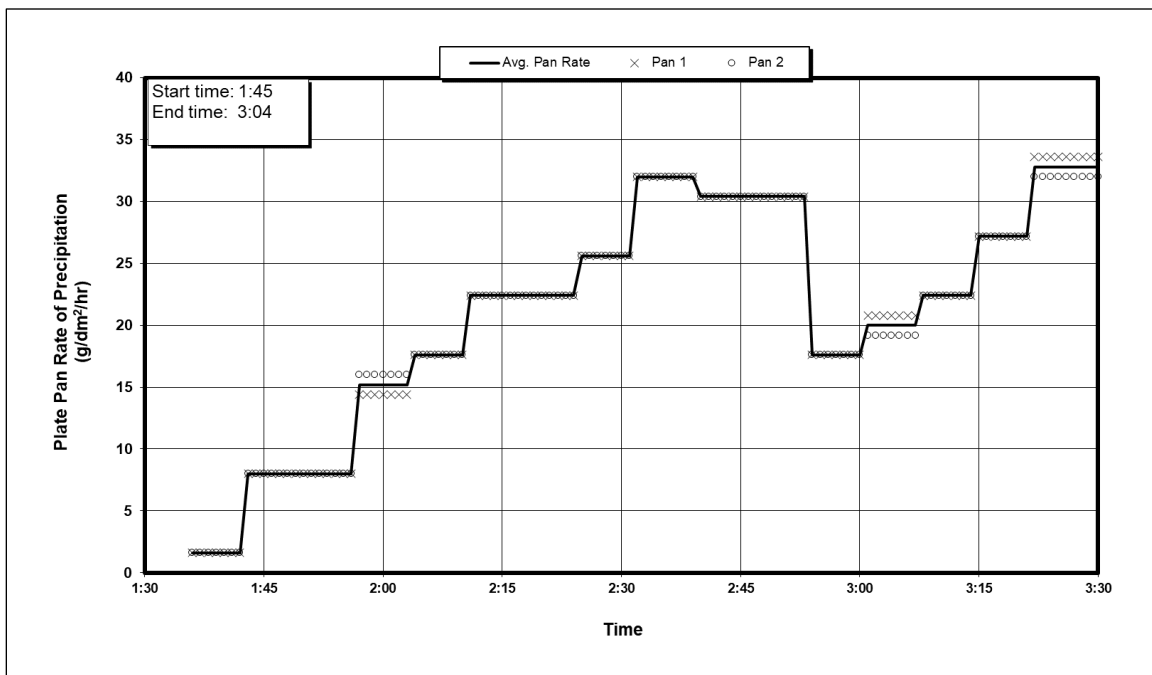


Figure 3.9: Rate of Precipitation vs Time, ID # 24

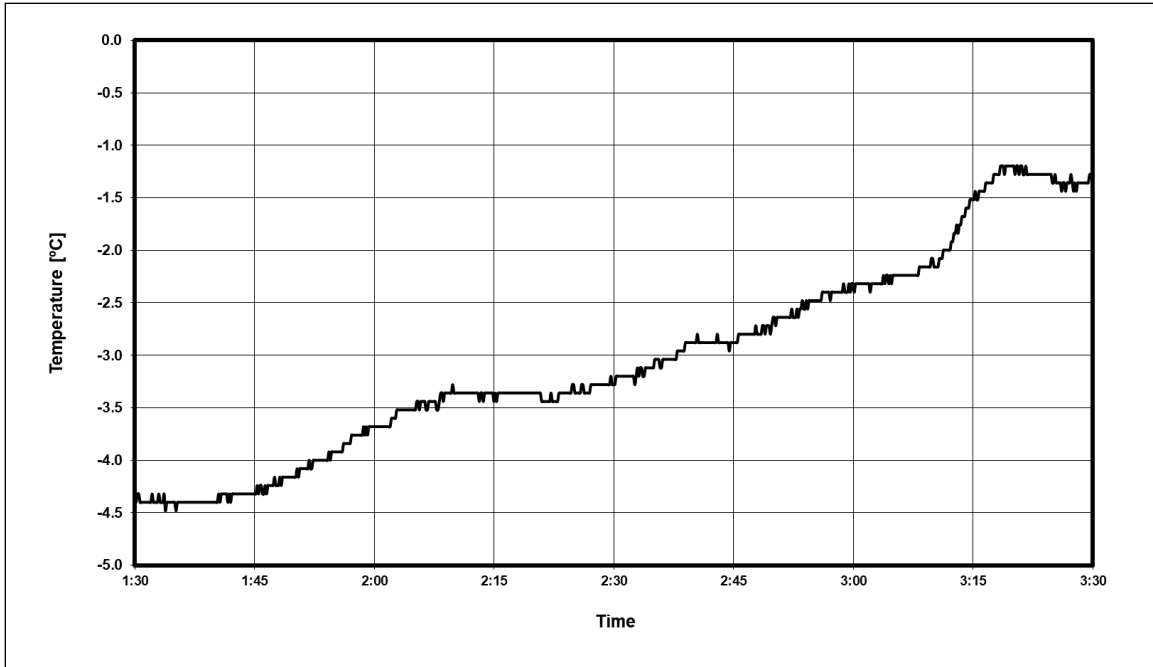


Figure 3.10: Temperature vs Time, ID # 24

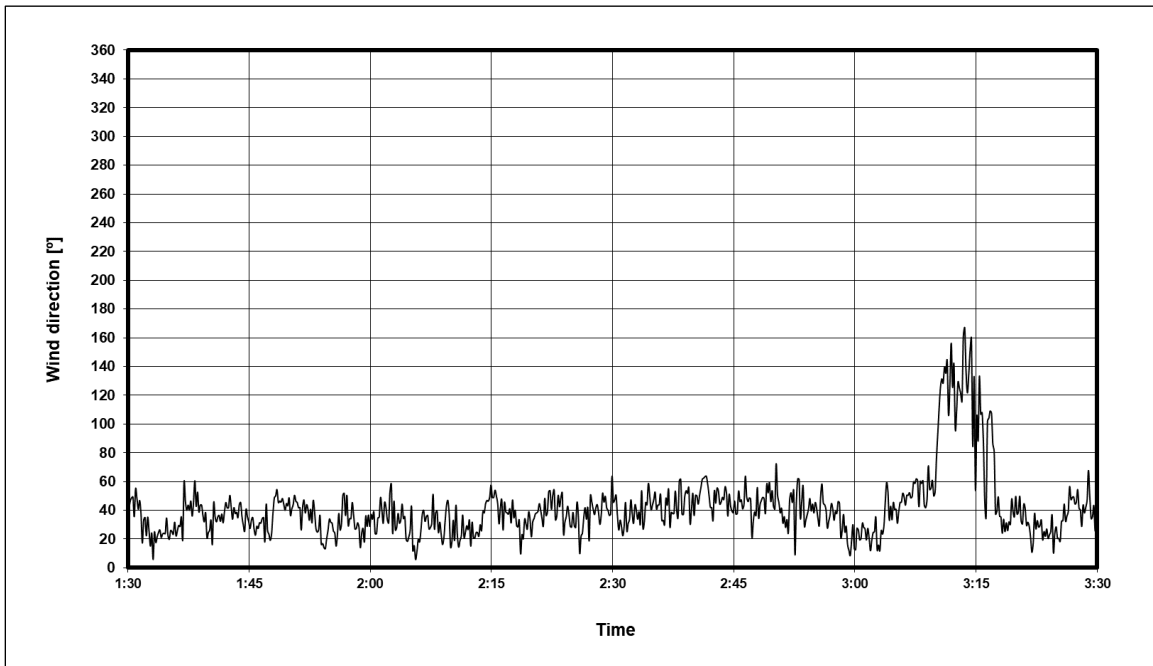


Figure 3.11: Wind Direction vs Time, ID # 24

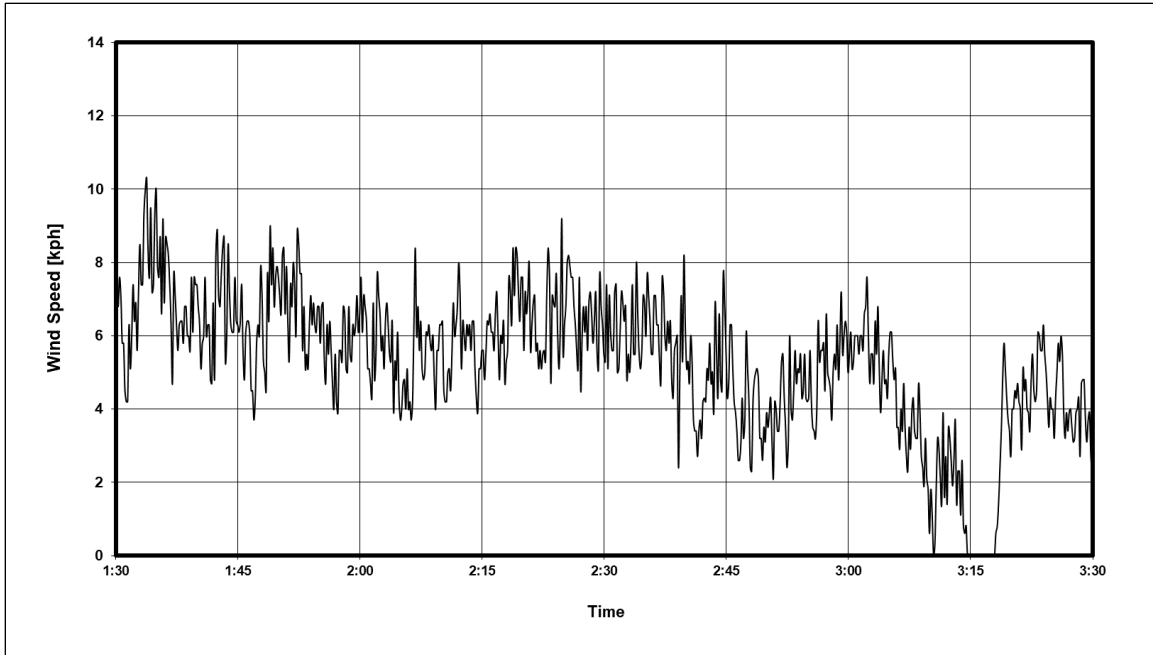


Figure 3.12: Wind Speed vs Time, ID # 24

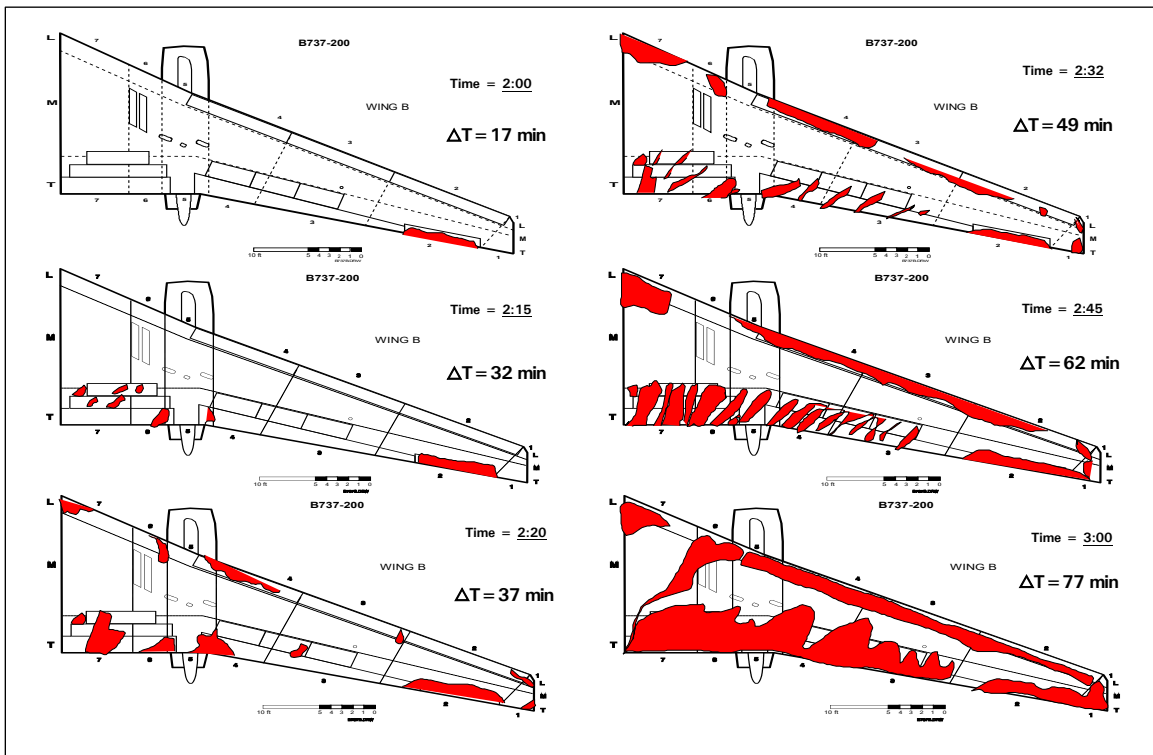


Figure 3.13: Progression of Failures, ID # 24

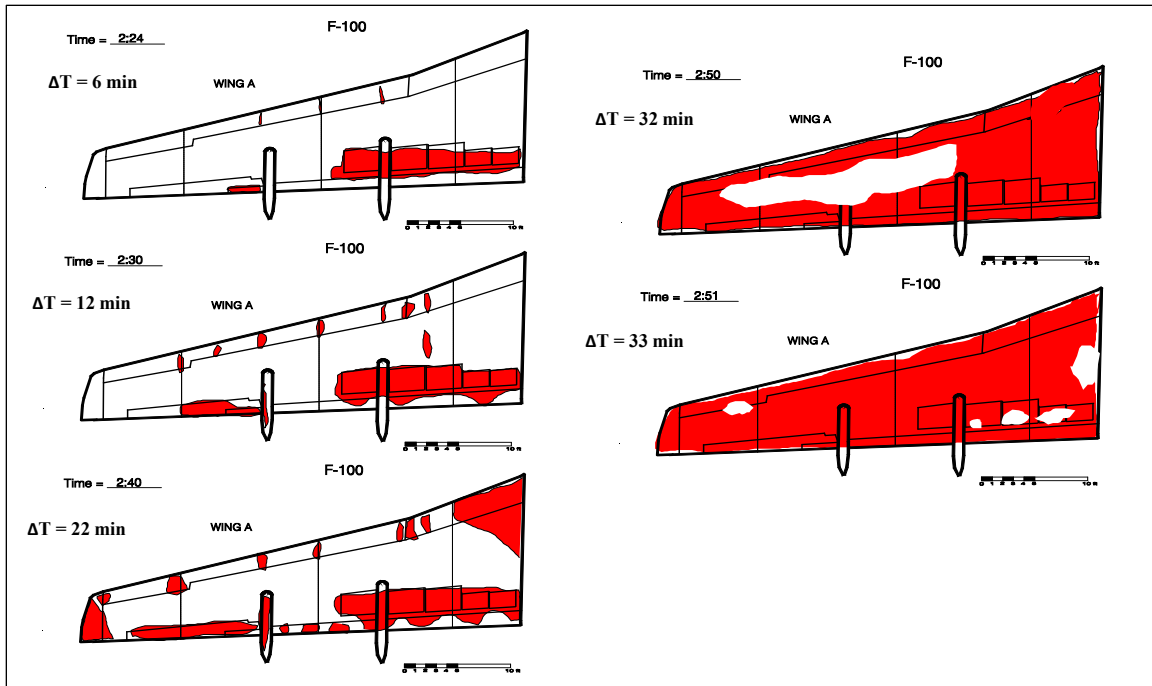


Figure 3.14: Progression of Failures, ID # 31

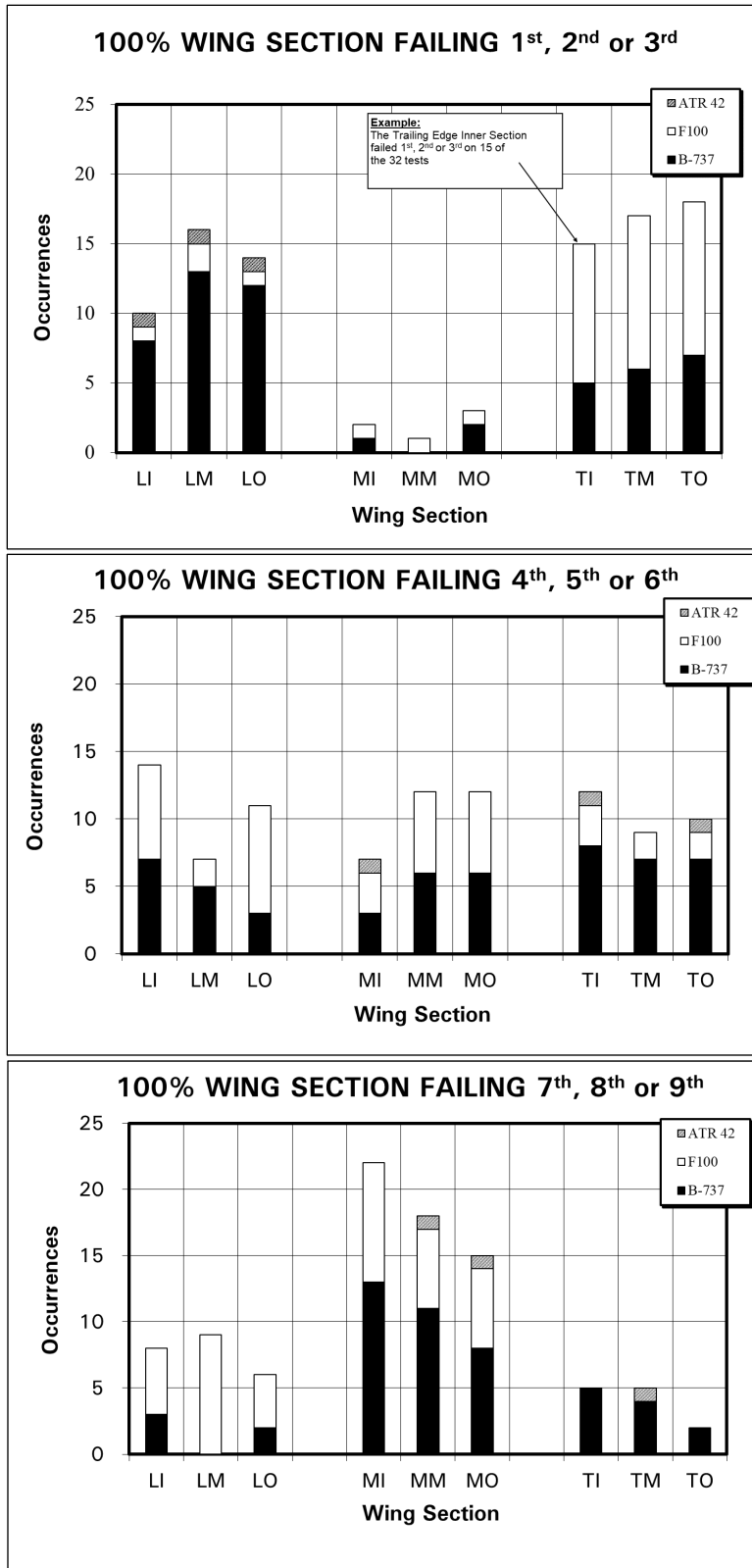
3.1.4 Secondary Data Reduction

In order to analyse the results of full-scale test data, a series of second-level charts were developed. This section of the report explains the various charts and the methods used in their production.

3.1.4.1 Failure Histograms

To determine the failure progression by aircraft wing section, the failure histograms shown in Figure 3.15 were developed. The aircraft wings for each full-scale test were split into nine sections as in Figure 3.5. The purpose of the chart was to depict the progression of wing failure by ranking the wing sections by their order of failure.

The charts showing percentage of fluid failure by wing section (for example Figure 3.4) were examined to determine failures located in each of the sections. The first wing section to undergo complete (100%) failure was ranked # 1, while the second section to fail was ranked # 2 and so on. The results in Figure 3.15 are sorted by aircraft type.



* Based on a 100% section failure.
 * 32 Tests.

Figure 3.15: Tabulation of Failure Patterns on Wing* by Aircraft Type

3.1.4.2 Depiction of First Failure

Several different charts were developed in order to depict the location of first failure occurrence on aircraft wings. The procedures used to complete each chart are described in this section.

Location of First Failure by Test ID (Figure 3.16)

Figure 3.16 was prepared using Boeing 737 and Fokker 100 full-scale test data from the 1996/97 test season. The failure contour drawings from each test were used to determine the first failure locations. Each location was then added to the individual wing diagrams with its corresponding ID #. The wind direction for each test ID is indicated by the arrow. For example, the Boeing 737 test ID # 1 initially failed on the leading edge. The arrow indicates that ID # 1 was the upwind wing in a crosswind condition.

Wing Grid Mapping of First Failure Occurrences (Figure 3.17 to Figure 3.19)

These charts were produced using data from 1996/97 Boeing 737 and Fokker 100 tests, as well as McDonnell Douglas DC-9 tests from 1994/95 and 1995/96. Each wing was divided into a grid pattern. The grid size for each wing varied due to the different shapes and sizes of the aircraft wings. Using the failure contour drawings, the first failure locations for each test ID were determined. The first failure contour for each ID was then superimposed on the wing grid diagram in order to determine which grid elements the failures had occurred in. An occurrence of failure was counted when any failure was present in the grid. For example, for grid element # 32 in Figure 3.18, failures were present in only 3 of 16 tests at the time of first failure. Due to difficulties in determining failures in ice-pellet conditions, ID # 10 was not included in the totals of Figure 3.18 and Figure 3.22.

A review of tests performed in previous years was conducted to indicate first failure locations for other types of aircraft. The results of four BAe 146 and two Airbus A320 tests are shown in Figure 3.20.

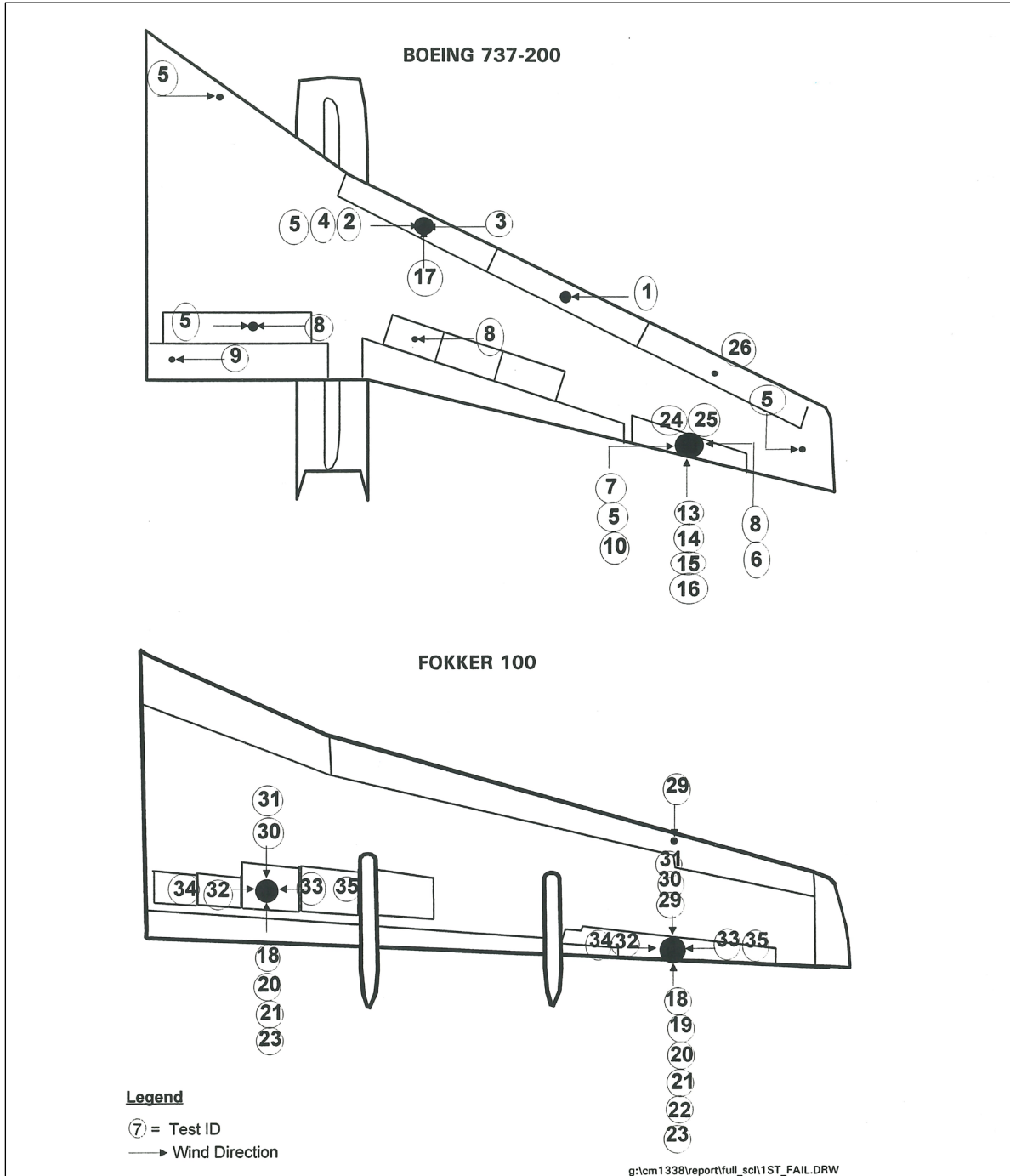


Figure 3.16: Location of First Failure by Test ID

3. DESCRIPTION AND PROCESSING OF DATA

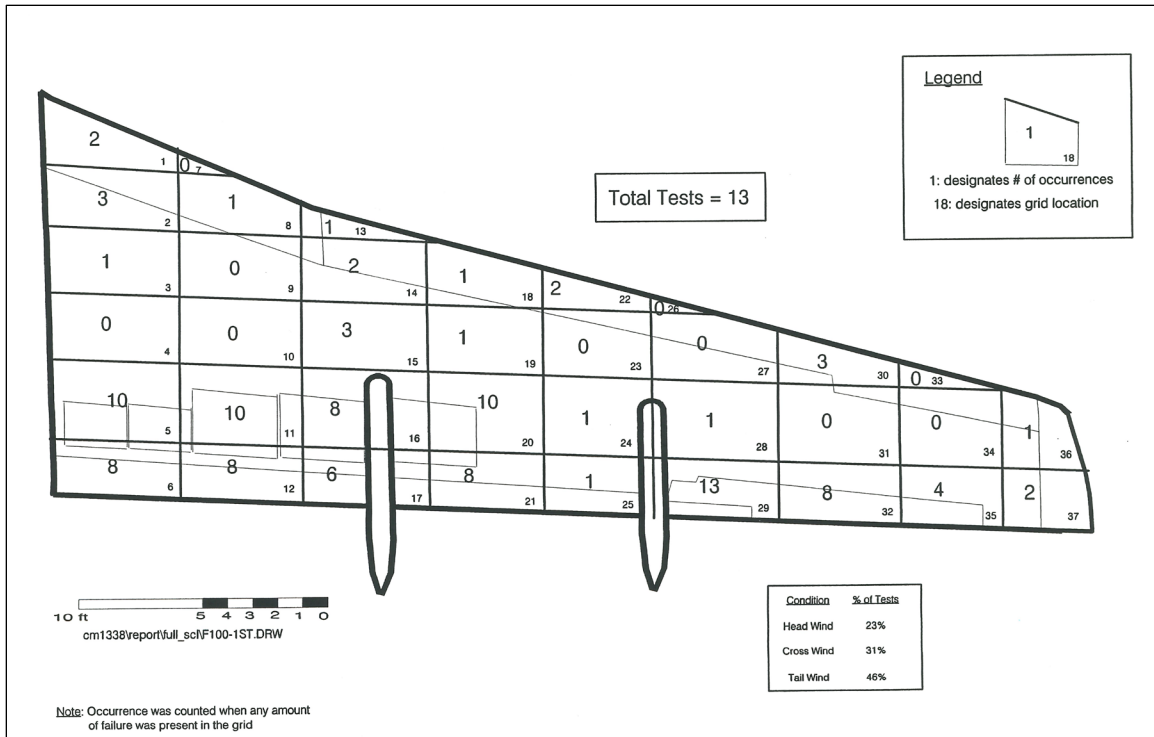


Figure 3.17: Occurrences of First Wing Failure by Wing Grid Location, Fokker 100

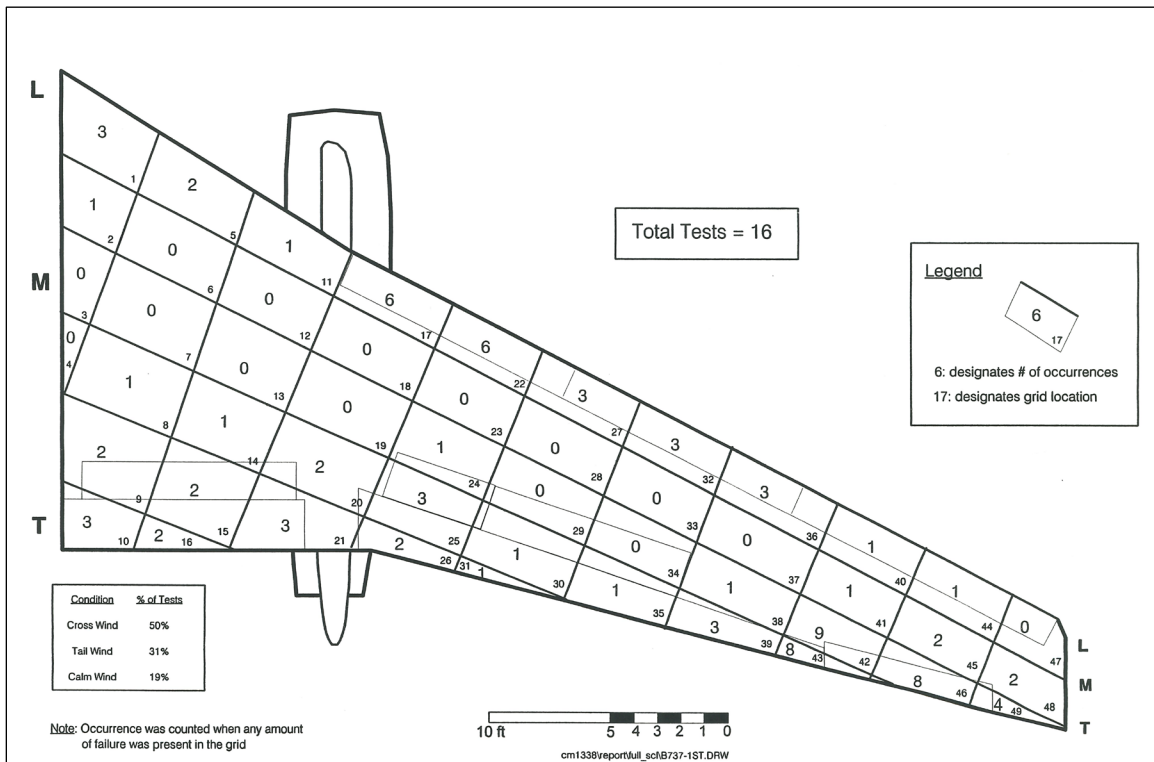


Figure 3.18: Occurrences of First Wing Failure by Wing Grid Location, Boeing 737-200

3. DESCRIPTION AND PROCESSING OF DATA

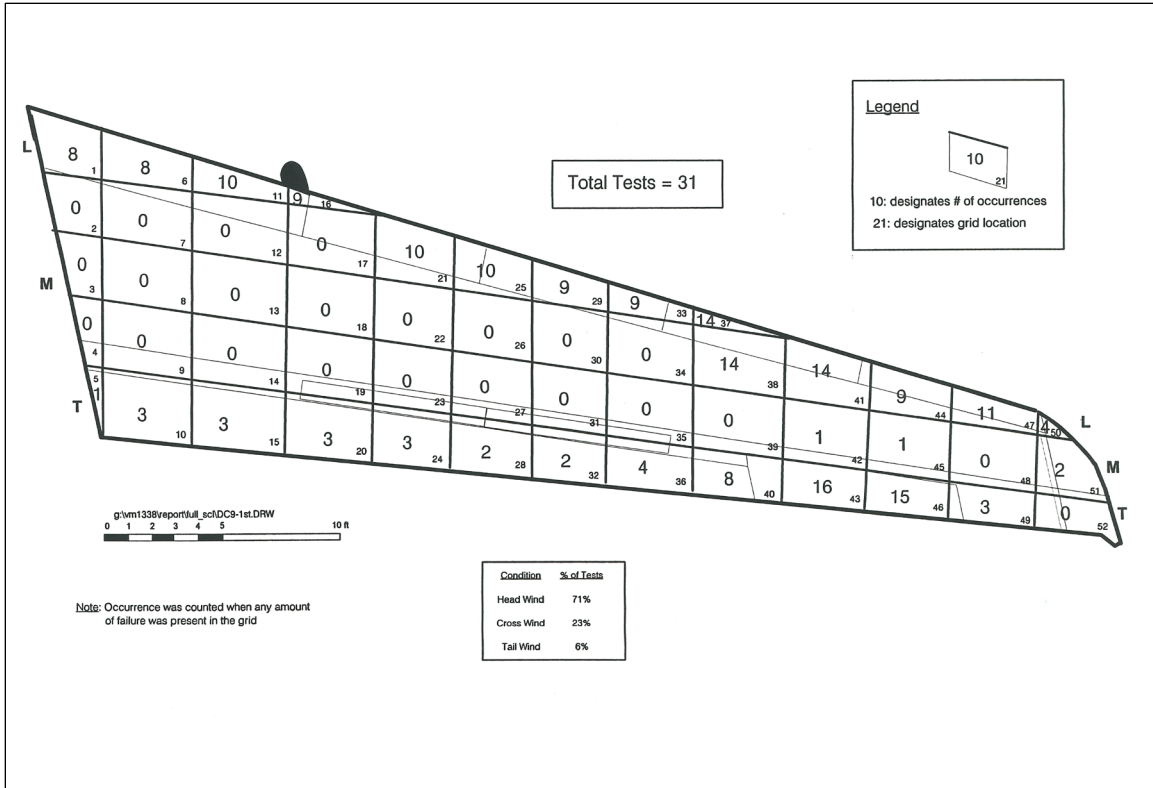


Figure 3.19: Occurrences of First Wing Failure by Wing Grid Location, McDonnell Douglas DC-9 Series 30

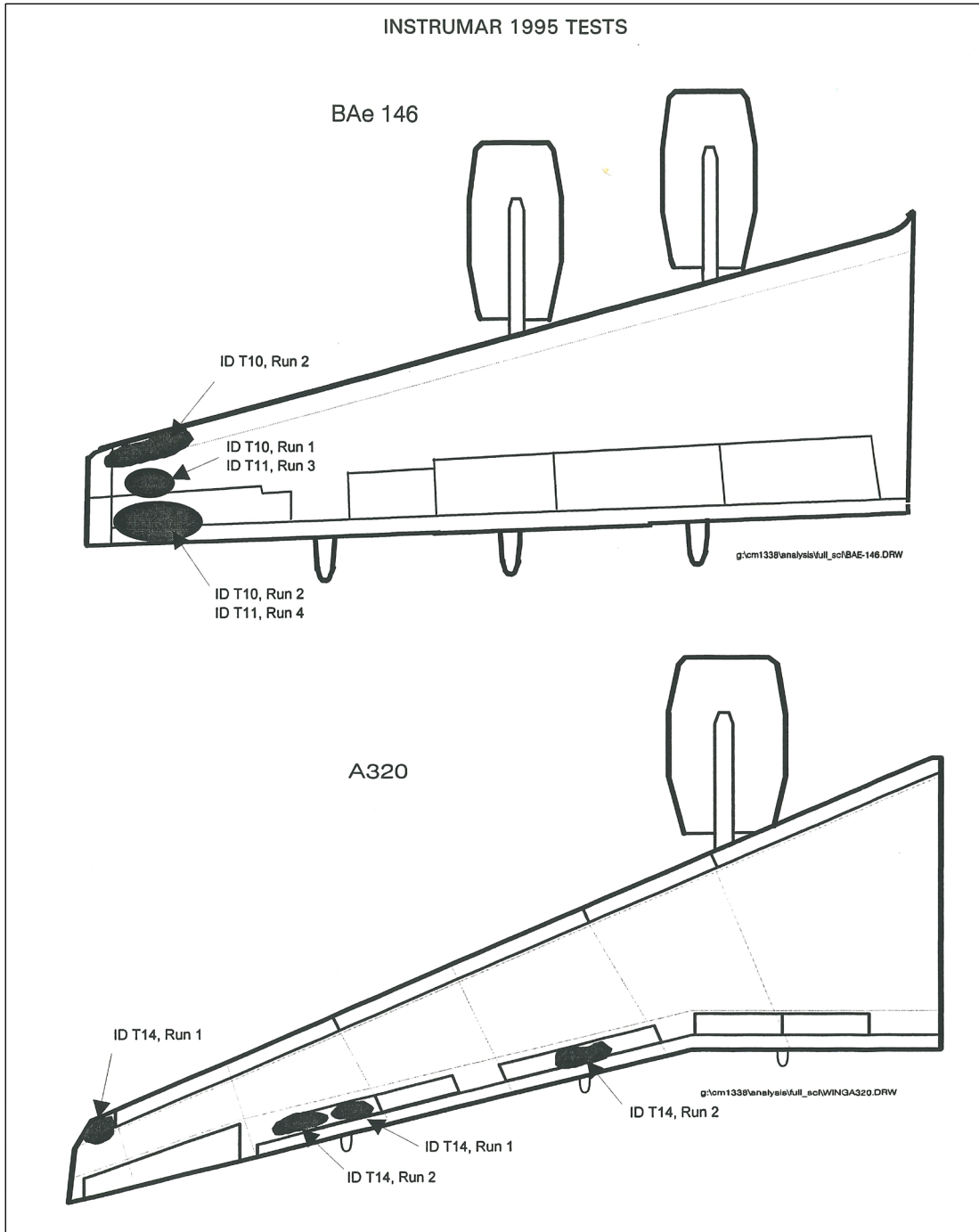


Figure 3.20: First Failure Locations of BAe 146 and Airbus A320 Tests

3.1.4.3 Depiction of 10% Wing Failure (Figure 3.21 to Figure 3.24)

Several charts and drawings were produced in order to depict the locations of 10% wing failures on different aircraft wings. The procedures used are described in this section.

Using the full-scale data, failure contour drawings representing 10% wing failure for each test ID were produced.

Wing Grid Mapping of 10% Failure Occurrences (Figure 3.21 to Figure 3.23)

These charts were produced using the same procedure used to prepare Figure 3.17 to Figure 3.19 (as explained in Subsection 3.1.4.2). In this case, the 10% wing failure depictions were superimposed onto the grid pattern diagrams to determine which grid elements contained this degree of failure. Since failures were not mapped beyond the location of first failure by Instrumar, only APS Aviation tests were used in Figure 3.23.

Percentage of Leading Edge Failure at 10% Wing Failure (Figure 3.24)

Figure 3.24 was prepared to illustrate what proportion of the leading edge had failed when 10% of the entire Boeing 737 or Fokker 100 wing had failed. Thirty usable tests were conducted on these aircraft during the 1996/97 test season, although only 29 were retained for the purpose of this study (ID # 10 was omitted due to problems related with failure calls in ice pellet conditions). Tests were separated into four categories: Boeing 737 with Type I fluid, Boeing 737 with Type IV fluid, Fokker 100 with Type I fluid and Fokker 100 with Type IV fluid. The failure contours for each test ID at 10% wing failure were examined to determine if leading edge failures were present at this point and to what degree the failures had progressed. If leading edge failure had occurred, the percentage of failure was calculated. For example, the first bar in Figure 3.24 shows that eleven Fokker 100 tests had between 0 and 10% leading edge failure when 10% of the entire wing failed. Nine were Type I tests and two were Type IV tests.

3. DESCRIPTION AND PROCESSING OF DATA

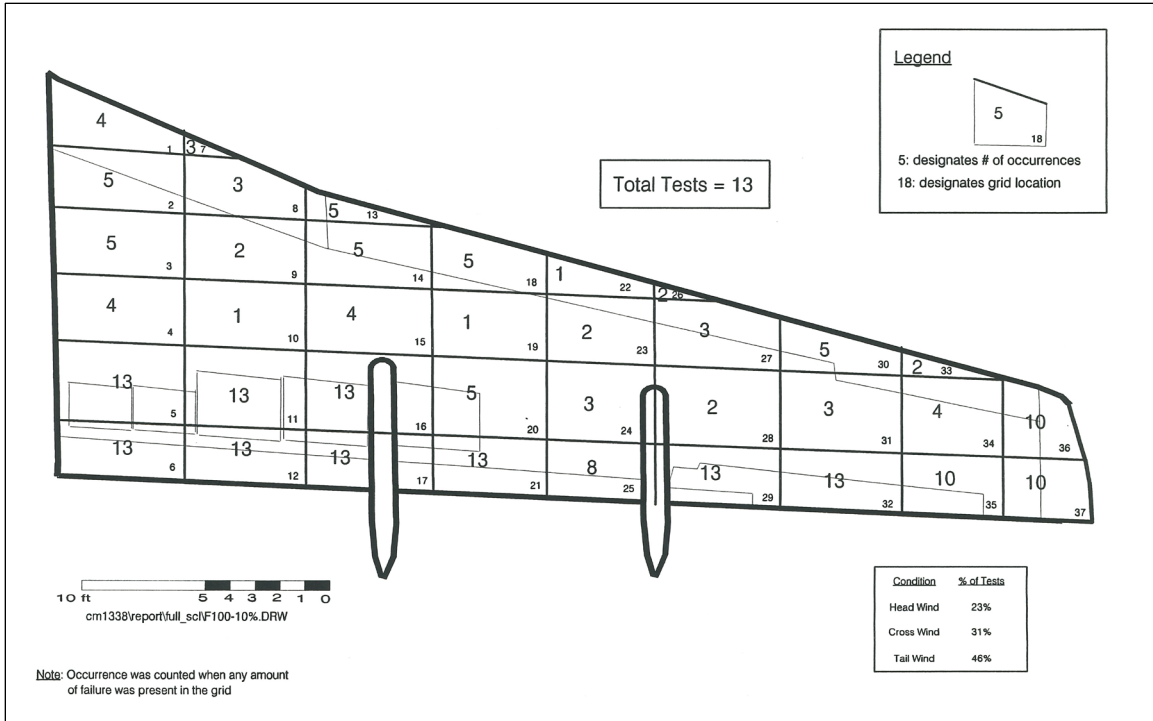


Figure 3.21: Occurrences of Failure by Wing Grid Location – 10% Wing Failure Level – Fokker 100

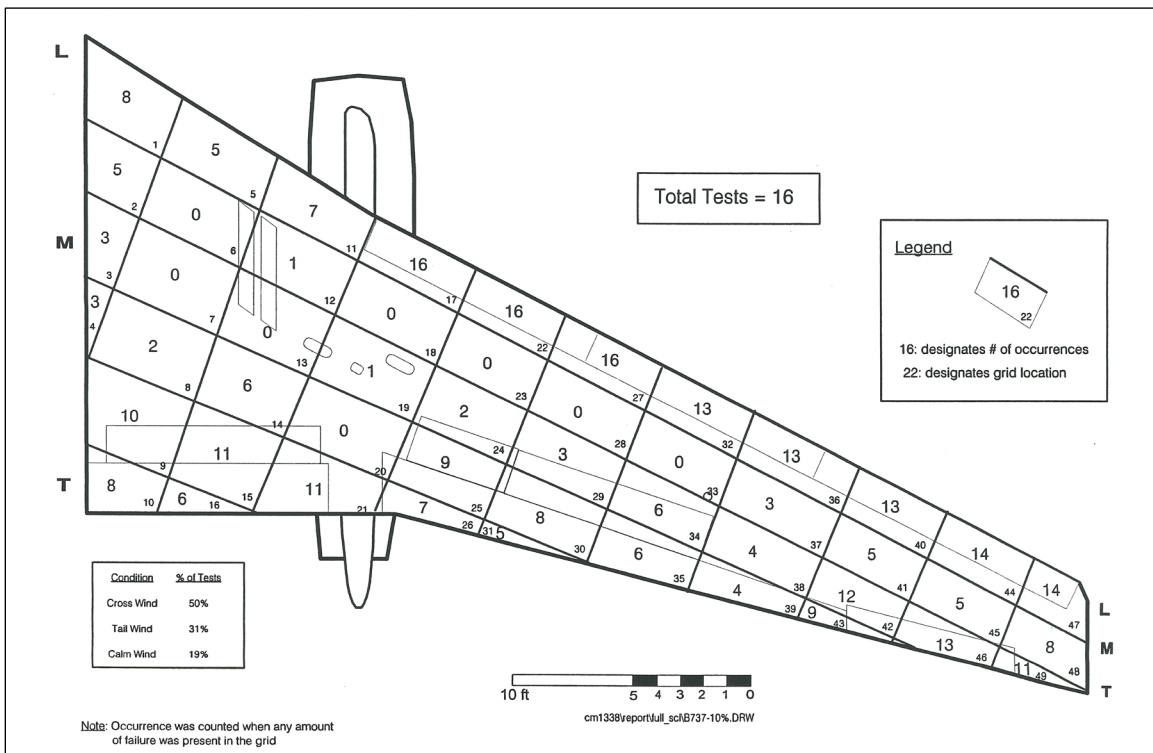


Figure 3.22: Occurrences of Failure by Wing Grid Location – 10% Wing Failure Level – Boeing 737-200

3. DESCRIPTION AND PROCESSING OF DATA

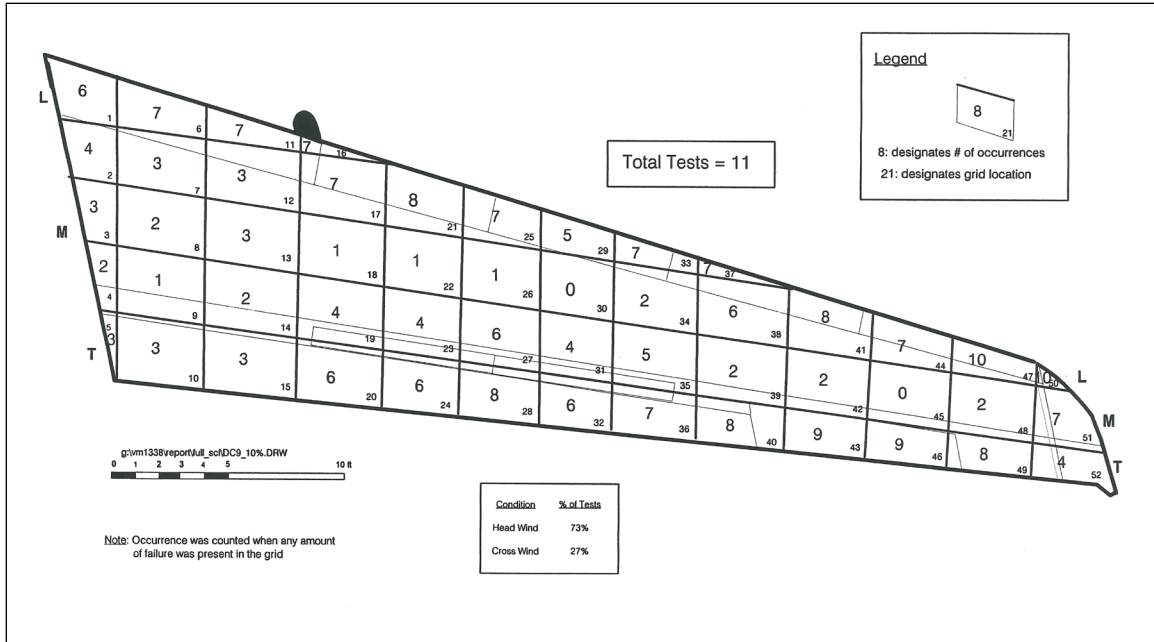


Figure 3.23: Occurrences of Failure by Wing Grid Location – 10% Wing Failure Level – McDonnell Douglas DC-9 Series 30

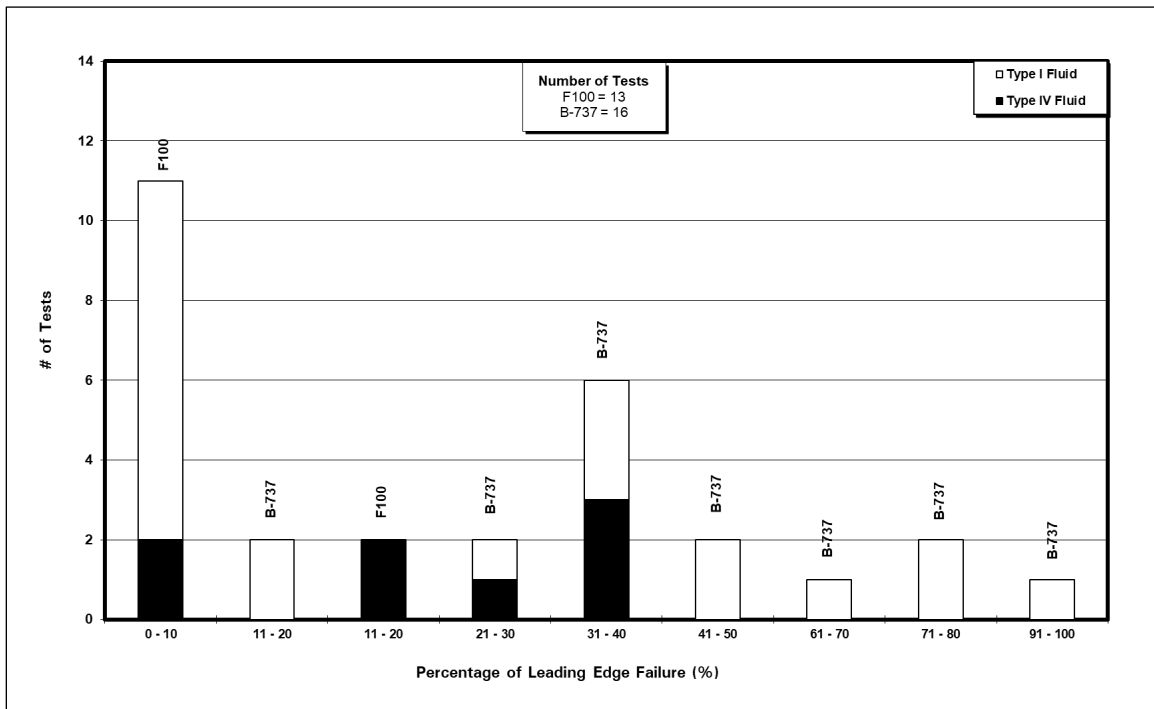


Figure 3.24: Percentage of Leading Edge Failure at 10% Wing Failure

3.1.4.4 Data Reduction of Wing Samples

The Transportation Development Centre requested that APS provide data that would assist in the determination of appropriate ice sensor locations for Boeing 737 and Fokker 100 aircraft.

During the course of the 1996/97 full-scale test season, thirty usable tests were conducted with Type I and Type IV fluids on Boeing 737 and Fokker 100 aircraft wings. Fluid samples were collected by APS personnel at eleven predetermined points on the aircraft wings several times during each test. The wing sample locations for Boeing 737 and Fokker 100 aircraft are shown in Figure 2.5. Refractive index measurements were made on each fluid sample collected in order to determine its freezing point. The refractive index is related to the concentration of glycol present in each sample. Measurements were obtained using a hand-held Brix-scale refractometer. Sample data were compiled and later used to evaluate potential sensor locations.

Since some ice sensors may detect the concentration of water present in the solution over the sensor head, it was useful to convert the Brix values of each fluid sample to concentration of water. The Type I and Type IV fluids used in testing, Union Carbide ADF XL54 and ULTRA+, contain glycol, water, and additives in their concentrated forms (ADF contains 92% glycol, ULTRA+ contains 60% glycol). In order to determine the percentages of glycol and water present in each solution following dilution, Figure 3.25 was developed. It must be noted that this chart provides only approximate values, since approximate percentages of glycol, water and additives were used in its design. The Brix values of all fluid samples were converted to concentration of glycol and water using this chart.

To identify which locations would be most suitable for ice sensor placement, Brix (glycol, water concentration) values needed to be calculated for each sample location at the time of wing first failure, 10% failure, and 25% failure. Sample collection times did not usually coincide with the specified wing failure times, and as a result, a method for determining these values was devised. Sample data for each aircraft type, fluid type and sample location were plotted on charts in relation to the different wing failure stages. An example of the charts is shown in Figure 3.26. In this case, the solid line that crosses the x axis at 0 minutes represents the first failure time. Samples collected prior to first wing failure appear to the left of the solid line, while samples collected following first failure appear to the right.

The chart shown in Figure 3.26 represents all the sample data collected during the course of full-scale Type I tests on the Fokker 100 aircraft at sample location # 10 (wing sample locations are shown in Figure 2.5). In this chart, all data are shown in relation to time of wing first failure. For example, ID # 20 started five minutes prior to first wing failure with a 34° Brix. The two subsequent samples from ID # 20 were

taken 2 and 18 minutes following first failure and had Brix values of 17° and 4°, respectively. The line joining the points intercepts the first failure line at 20° Brix. The other curves on the chart represent the sample data collected at the same sample location during the course of the different tests (test ID are indicated for each curve). Using this information, it is possible to determine the fluid freeze point range at sample location # 10 for this fluid and aircraft type. All the curves in Figure 3.26 intercept the first failure line between 15° and 24° Brix which corresponds to a temperature range from 11 to 23°C. As a result, this would be the expected Brix value range of Type I XL54 fluid at sample location # 10 for Fokker 100 tests at the time first failure occurs anywhere on the wing. This Brix range could also be converted to percentage of water using Figure 3.25. In this case, the Brix range of 15° to 24° corresponds to 64% to 78% of water in these samples.

Similar charts were prepared for each sample location, aircraft type, and fluid type at wing first failure, 10% and 25% failure. The charts at 10% and 25% failure were prepared using the same method as the first failure chart shown in Figure 3.26. Test sample data were plotted on the charts in relation to the 10% or 25% failure time of each test. Using the combined data in each chart, it is possible to determine the Brix value range, the water - glycol concentration range or the freezing point temperature range at each fluid sample location, related to different percentages of entire wing failure. In addition, the measurements taken by Optima at the two positions on the leading edge were plotted on similar charts.

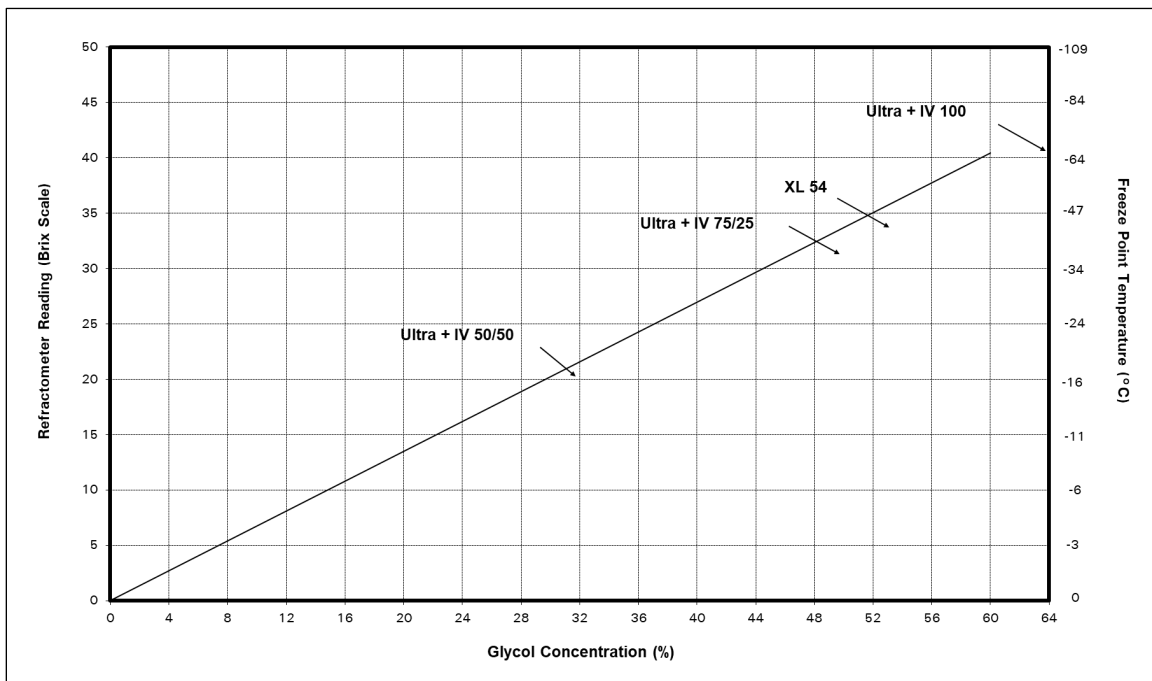


Figure 3.25: Brix vs Glycol Concentration of Union Carbide ADF & Ultra +

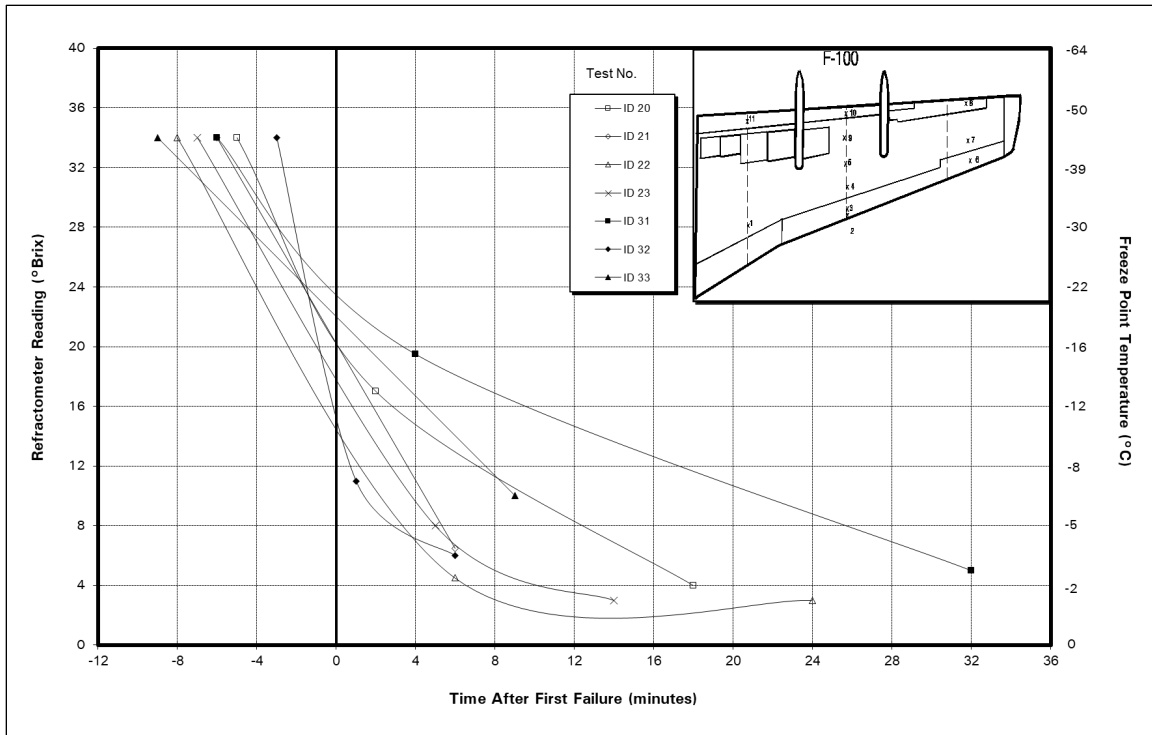


Figure 3.26: Refractometer Readings of Wing Samples Relative to First Failure, Fokker 100, Type I, Location # 10

3.1.5 Video and Still Photo Descriptions

During all full-scale test sessions, 8 mm video and 35 mm still photographic records were made by APS Aviation personnel. Originally, two personnel shared the video and photo documentation duties. This procedure was modified following the tests on January 28, 1997. Tests conducted following this date were recorded by two video personnel and one still photographer to enable more precise photography of the failing fluid. A digital video camera was rented for tests on February 5, 1997, in order to compare the digital and 8 mm images. Since no major difference in image quality was observed, the 8 mm video was used in all the remaining test sessions. Video and photo evidence were taken at all stages of testing, from the set-up and fluid application process to the contamination and failure of the fluids. Complete lists of video and photo records are provided in Table 3.2 and Table 3.3.

Table 3.2: List of Photo References

Book #	Order	Description	Date
1	1	Full-Scale a/c Tests at YUL (F-100 American Airlines), ID # 39 - 40, neg. 1212	December 13, 1996
1	2	Full-Scale a/c Tests at YUL (B-737 Canadian Airlines), ID # 1-4, neg. 0881	January 16, 1997
1	3	Full-Scale a/c Tests at YUL (B-737 Canadian Airlines), ID # 5-8, neg. 1669	January 22, 1997
1	4	Full-Scale a/c Tests at YUL (B-737 Canadian Airlines), ID # 9-12, neg. 0125	January 25, 1997
1	5	Full-Scale a/c Tests at YUL (B-737 Canadian Airlines), ID # - 13-17, neg. 0128	January 28, 1997
1	6	Full-Scale a/c Tests - YUL (F-100 American Airlines), ID # 18-23	February 5, 1997
2	1	American Full-Scale (continuation - neg. in book)	February 5, 1997
2	2	TP, Inter-Canadian, Type I + Type IV	February 4, 1997
2	3	TP, Inter-Canadian, Type IV	February 7, 1997
2	4	Site, Snow on Plates	February 1, 1997
2	5	CRIQ Dry-out Tests, neg. 4922	February 10, 1997
3	1	Flat Plate Testing at AES Site	February 14, 1997
3	2	Hot Water Testing at AES Site	February 20, 1997
3	3	Full-Scale a/c Tests - YUL (B-737 Canadian Airlines), ID #24-28	February 21, 97
4	1	Visibility Tests YUL, Canadian Inter-Canadian	March 1, 1997
4	2	Full-Scale a/c Tests at YUL (F-100 American Airlines), ID # 29-35	March 6, 1997
4	3	General	March 1997
4	4	Winnipeg, DND Tests, neg. 03089702	March 8, 1997
5	1	AES Site Tests, neg. 04119701	April 11, 1997
5	2	Cabin views, neg. 03149701	March 14, 1997
5	3	Turboprop Tests ATR-42, Cabin views & Hot fluid tests, neg. 03149702	March 14, 1997
5	4	Freezing Fog Tests & Enhance Visibility, neg. RQ03259701	March 25, 1997
5	5	Enhance Visibility, neg. 03269701	March 26, 1997
5	6	Enhance Visibility, neg. RQ03269702	March 26, 1997
6	1	Fog & Enhance Visibility, neg. RQ03279701	March 27, 1997
6	2	Enhance Visibility, neg. RQ03279703	March 27, 1997
6	3	Enhance Visibility, neg. RQ03279704	March 27, 1997
6	4	Enhance Visibility, neg. RQ03279704	March 27, 1997
6	5	Enhance Visibility, neg. RQ03279705	March 27, 1997
6	6	Mirabel Nozzle Tests, neg. CM04099701	April 9, 1997
6	7	Mirabel Nozzle Tests, neg. CM04099702	April 9, 1997
6	8	Mirabel Nozzle Tests, neg. CM04099703	April 9, 1997
6	9	Mirabel Nozzle Tests, neg. CM04099704	April 9, 1997
6	10	Mirabel Nozzle Tests, neg. CM04099706	April 9, 1997

3. DESCRIPTION AND PROCESSING OF DATA

Table 3.3: Video Log for Tests Conducted During 1996/97

Video #	Video Name	Notes
1	Full-Scale Aircraft Tests at YUL - Inc. dry run - Dec. 13, 1996 (B-737 Canadian Airlines) - ID # 1-4 and 39-40	V1 - Jan 16, 1996
2	Full-Scale Aircraft Tests at YUL - Inc. dry run - Dec. 13, 1996 (B-737 Canadian Airlines) - ID # 1-4 and 39-40	V2 - Jan 16, 1996
3	Full-Scale Aircraft Tests at YUL (B-737 Canadian Airlines) - ID # 5-8	V1 - Jan 22, 1997
4	Full-Scale Aircraft Tests at YUL (B-737 Canadian Airlines) - ID # 5-8	V2 - Jan 22, 1997
5	Full-Scale Aircraft Tests at YUL (B-737 Canadian Airlines) - ID # 9-12	V1 - Jan 25, 1997
6	Full-Scale Aircraft Tests at YUL (B-737 Canadian Airlines) - ID # 9-12	V2 - Jan 25, 1997
7	Full-Scale Aircraft Tests at YUL (B-737 Canadian Airlines) ID # 13-17	V1 - Jan 28, 1997
8	Full-Scale Aircraft Tests at YUL (B-737 Canadian Airlines) ID # 13-17	V2 - Jan 28, 1997
9	Turboprop Aircraft Thickness Tests at YUL (ATR 42 Inter-Canadian) ID # T7-T8	Feb. 04, 1997
10	Turboprop Aircraft Thickness Tests at YUL (ATR 42 Inter-Canadian) ID # T7-T8	Feb. 04, 1997
11	Full-Scale Aircraft Tests at YUL (F100 American Airlines) ID # 18-23	V1 - Feb. 05, 1997
12	Full-Scale Aircraft Tests at YUL (F100 American Airlines) ID # 18-23	V2 - Feb. 05, 1997
13	Deicing Fluid Evaporation Tests	Feb. 20, 1997
14	Full-Scale Aircraft Tests at YUL (B-737 Canadian Airlines) - ID # 24-28	Feb. 21, 1997
15	Full-Scale Aircraft Tests at YUL (B-737 Canadian Airlines) - ID # 24-28	Feb. 21, 1997
16	Documentation of Wing Area Visible to Flight Crew	Mar. 01, 1997
17	Full-Scale Aircraft Tests at YUL (F100 American Airlines) ID # 29-35	Mar. 06, 1997
18	Full-Scale Aircraft Tests at YUL (F100 American Airlines) ID # 29-35	Mar. 06, 1997
19	Turboprop Thickness Tests at DND - Winnipeg (DHC-8) - ID # T12- T17	Mar. 08, 1997
20	Full-Scale Aircraft Tests at YUL (ATR 42 Inter-Canadian) - ID # 36-38	Mar. 14, 1997
21	Snow Flake Absorption Tests at APS site - Dorval	Mar. 22, 1997
22	Snow Flake Absorption Tests at APS site - Dorval	Mar. 22, 1997
23	Snow Flake Absorption Tests at APS site - Dorval	Mar. 25, 1997
24	Snow Flake Absorption Tests at APS site - Dorval	Mar. 25, 1997
25	Enhanced Visibility Tests at NRC	Mar. 25 - 27, 1997
26	Fluid Application Tests at Mirabel Airport	Apr. 09, 1997
27	Full-Scale Test procedure - FAA off-line edit 1st version	Jan. 1997
28	Full-Scale Test procedure - FAA off-line edit pre-edit	Jan. 1997
29	Bad applications, Good applications from Test Sessions	May 1997
30	Bad applications, Good applications from Test Sessions - SAE off-line edit	May 07, 1997
31	Full-Scale aircraft test program (5 copies)	WInter-1996/97
32	Observations on Type IV Fluid Application (6 copies)	May 1997
33	Holdover Time Field Testing at APS Site	Jan. 31, 1997
34	Holdover Time Field Testing at APS Site	Dec. 19, 1996

3.1.6 Evolution of Test Procedures

During the test season, full-scale aircraft test procedures and equipment were updated and/or enhanced to meet the various requirements dictated by different weather conditions and logistical factors. This section highlights some issues and concerns that needed to be addressed during testing, and documents them to support development of procedures for future tests:

- *First failure identification*: Due to the rapid propagation of failures, especially in the case to Type I tests, the time and precise location of first failure were sometimes missed. In certain tests, rapid failure had progressed to the 25% level at the time of documenting the first failure contour. Procedures and training must emphasize the requirement to identify the precise location of first failure, and additional observers are to be assigned from the test team complement to assist in failure identification when rapid progress of failure is expected. A further discipline can be added by requiring observer comments on wing conditions at defined intervals while awaiting occurrence of first failure;
- *Accuracy of wing plans*: It was found that using generic wing plans, available from the literature test forms, did not always provide accurate detail for the actual wings tested. Accurate wing details must be portrayed on the data form wing plan to support accuracy in drawing failure locations and patterns. Modification of generic wing plans, based on inspection of actual test wings sometime prior to the test session, is necessary;
- *Lighting*: The new approach to lighting the wings for the tests provided a marked improvement in illumination over previous test seasons. Further enhancements to provide backup against light or generator failure were found to be necessary;
- *Fluid samples*: Fluid samples collected from the initial test session possibly underwent evaporation. Procedures for subsequent test sessions required gathering a larger sample, keeping the samples cold, and testing samples for refractive index immediately following the test session;
- *Video documentation of failures*: In sessions involving simultaneous tests on two wings, it proved necessary to dedicate a video person to each wing in order to provide continuous monitoring, and to avoid missing important events. It is important to record significant set-up events, such as identification and marking of wing sample locations;
- *Turboprop test procedure*: Testing on high wing turboprop aircraft presented unique challenges. To understand the impact of propeller wind streams on fluid failure patterns, the engine and propellers were operated for five minutes following fluid application. During the single test session, which happened to be the final session in the series of aircraft tests, it was found that fluid failure had already occurred before test observers could gain access to the wing after

engines were shut down. A further complication was caused by the height of the wing, which required additional high stairs to enable adequate access by team members; and

- *Influence of heated deicing fluid:* A further perspective can be gained by a better understanding of wing surface temperatures following application of heated fluid. This is particularly important under freezing rain conditions. This can be accomplished by periodic temperature measurements using a temperature probe mounted on an extension pole.

3.2 Fluid Thickness Characteristics

This subsection will discuss the processing of data as they relate to fluid thickness tests which were conducted.

3.2.1 Overview of Test Sessions

Table 3.4 presents a summary of all fluid thickness tests conducted on various aircraft during the winter season 1996/97. Figure 3.27 provides a graphical representation of the types of tests conducted.

Operational summaries of each test session complemented reports on general events, conditions, problems and recommendations for subsequent tests. These are presented in Appendix G.

Tests T1 and T2, conducted on December 13, 1996, were part of a dry run to evaluate test procedures, and no usable data were gathered. AMR services staff performed the spray function.

Tests T3 to T6 and T11 (5 tests) were thickness tests on Boeing 737 aircraft conducted during periods of no precipitation in the course of fluid failure trials. Canadian Airlines International staff performed the fluid applications.

Tests T7 to T10 were conducted on an ATR 42 aircraft at Dorval Airport with the objective of determining the impact of propeller wash on fluid film thickness over the wing surface. Trials using only Type I fluid were sprayed by Inter-Canadian staff, while trials using Type IV fluid were applied by AMR services staff.

Tests T12 to T17 were similar tests conducted with the Department of National Defence at Winnipeg on a DHC Dash 8 aircraft. Fluid applications were performed by military staff.

Tests T18 to T23 had the objective of evaluating the influence on fluid application of different fluid nozzles and different spray techniques. Following discussions with the spray operator, the tests performed varied slightly from the initial plan and are described in a subsequent section. Fluid applications were performed by AéroMag 2000 staff.

3. DESCRIPTION AND PROCESSING OF DATA

Table 3.4: Listing of Aircraft Thickness Tests – Winter 1996/97

ID #	Test Location	Date	Run #	AIRLINE	A/C Type	A/C Wing	Fluid Name	Type I Fluid Quantity (L)	Type IV Fluid Quantity (L)	APS Air Temp (°C)	Observed wind Head/Tail/Cross	APS Wind Direct. (deg.)	APS Wind Speed (kph)	A/C Orient. (E of N) (deg.)	Props Running Y/N	Type IV Nozzle Type	Comments
T1	YUL	Dec-13-96	1	American	F100	Port	XL54	65	65	-0.2	head	40	20	40	N/A	Wand	dry run
T2	YUL	Dec-13-96	2	American	F100	Port	Ultra + /XL54	65	65	-0.3	head	40	20	40	N/A	Wand	dry run
T3	YUL	Jan-16-97	1	Canadian	B-737	Strbd	Ultra/XL54	25	50	-0.3	cross	183	13	55	N/A	Task Force Tips	
T4	YUL	Jan-22-97	2	Canadian	B-737	Port	Ultra		20	-7.4	cross	38	6	270	N/A	Task Force Tips	
T5	YUL	Jan-25-97	3	Canadian	B-737	Port	Ultra + /XL54	100	75	-0.5	cross	137	18	240	N/A	Task Force Tips	Inadequate application
T6	YUL	Jan-25-97	3	Canadian	B-737	Port	Ultra +		175	-0.3	cross	138	15	240	N/A	Task Force Tips	Ultra + applied again on old fluid
T7	YUL	Feb-04-97	1	Inter-Canadian	ATR 42	Port	XL54	251		-10.0	head	10	17	n/a	N	N/A	
T8	YUL	Feb-04-97	2	Inter-Canadian	ATR 42	Port	XL54	124		-10.0	head	10	17	n/a	Y	N/A	
T9	YUL	Feb-07-97	1	Inter-Canadian	ATR 42	Port	Ultra + /XL54	90	90	-3.0	head	270	10	280	Y	Wand	Sprayed by AMR Services
T10	YUL	Feb-07-97	2	Inter-Canadian	ATR 42	Port	Ultra + /XL54	135	135	-3.0	head	270	10	280	Y	Wand	Sprayed by AMR Services
T11	YUL	Feb-21-97	1	Canadian	B-737	Strbd	Ultra + /XL54	100	50	-3.0	calm wind	54	6	50	N/A	Task Force Tips	
T12	YWG	Mar-08-97	1	DND	DHC-8	Strbd	Type I Military	N/A		-6.0	head	360	30	360	N	N/A	
T13	YWG	Mar-08-97	2	DND	DHC-8	Strbd	Type I Military	70		-6.0	head	360	30	360	N	N/A	
T14	YWG	Mar-08-97	3	DND	DHC-8	Strbd	Type I Military	160		-6.0	head	360	30	360	N	N/A	
T15	YWG	Mar-08-97	4	DND	DHC-8	Strbd	Type I Military	130		-6.0	head	360	30	360	Y	N/A	
T16	YWG	Mar-08-97	5	DND	DHC-8	Strbd	Type I Military	100		-6.0	cross	360	30	360	Y	N/A	
T17	YWG	Mar-08-97	6	DND	DHC-8	Port	Type I Military	100		-6.0	cross	360	30	270	Y	N/A	
T18	YMX	Apr-09-97	1	CANAIR	B-737	Strbd	Ultra + /XL54	*	54	-7.0	head	340	30	350	N/A	Nepiro	* 333 Litres of XL54 used for 6 tests
T19	YMX	Apr-09-97	2	CANAIR	B-737	Port	Ultra + /XL54	*	51	-7.0	head	340	30	350	N/A	Akron	* 333 Litres of XL54 used for 6 tests
T20	YMX	Apr-09-97	3	CANAIR	B-737	Strbd	Ultra + /XL54	*	41	-7.0	head	340	30	350	N/A	Elephant b Standard	* 333 Litres of XL54 used for 6 tests
T21	YMX	Apr-09-97	3A	CANAIR	B-737	Strbd	Ultra + /XL54	*	136	-7.0	head	340	30	350	N/A	Elephant b Optional	* 333 Litres of XL54 used for 6 tests
T22	YMX	Apr-09-97	4	CANAIR	B-737	Port	Ultra + /XL54	*	24	-7.0	head	340	30	350	N/A	Elephant b Optional	* 333 Litres of XL54 used for 6 tests
T23	YMX	Apr-09-97	5	CANAIR	B-737	Port	Ultra + /XL54	*	27	-7.0	head	340	30	350	N/A	Elephant b Optional	* 333 Litres of XL54 used for 6 tests

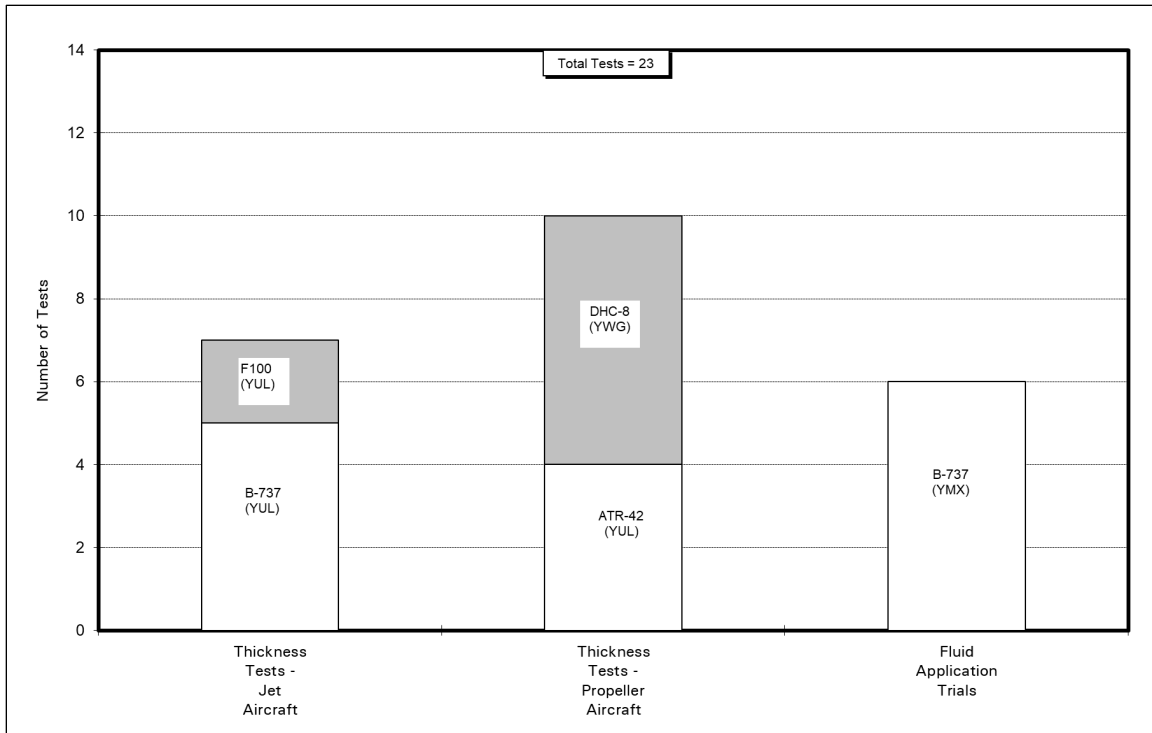


Figure 3.27: Types of Fluid Thickness Tests Conducted Winter 1996/97

3.2.2 Breakdown of Test Variables

All tests in this series were conducted in conditions of no precipitation. With the exception of tests at Winnipeg, fluids used were Type IV Union Carbide Ultra + (neat) and Type I Union Carbide (XL54). Military Type I fluid was used during tests at Winnipeg.

The operator's standard spray procedures were used in all tests to determine the stabilized thickness of fluid. The fluid application trials at Mirabel required the spray operator to follow special instructions for spraying on some occasions. A variety of fluid nozzles were used in these fluid application trials.

3.2.3 Descriptions of Fluid Thickness Data and Analysis

This section will provide descriptions and explanations of collected data, sub-divided into specific test situations as they occurred.

3.2.3.1 Fluid thickness Tests on Jet Aircraft

Data were organized and presented in three graphical formats for visual presentation and analysis. These formats correspond to the presentation formats followed in the

report on the previous study on fluid thickness. Typical charts for a single test follow, showing the rate of thinning of the fluid, the profile of stabilized fluid over a wing chord, and a wing plan showing distribution of fluid thickness over the entire wing surface.

Figure 3.28 shows rate of thinning for a Type IV fluid at measurement points on a wing surface. These curves provide initial and stabilized thickness values for each reference point. Locations of these points are illustrated on a wing plan form in the inset box. The title block indicates the specifics of the test condition (date, aircraft type, fluid, temperature, wind speed, and nozzle type).

Figure 3.29 shows a profile of stabilized fluid thickness over the wing chord. On the same chart, thickness values measured on flat plates during simultaneous testing are shown.

Figure 3.30 is a presentation of fluid thickness values at measured reference points on a wing plan.

Complete sets of these charts for all tests are provided in Appendix D.

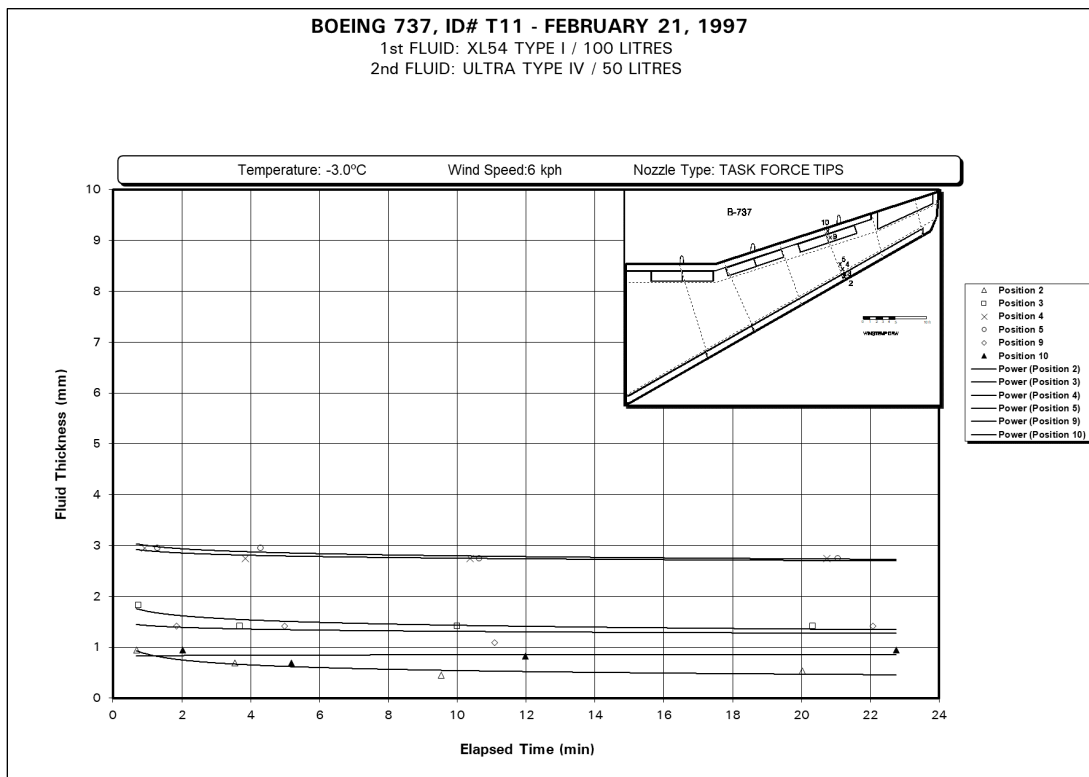


Figure 3.28: Fluid Thickness Decay of Various Wing Positions

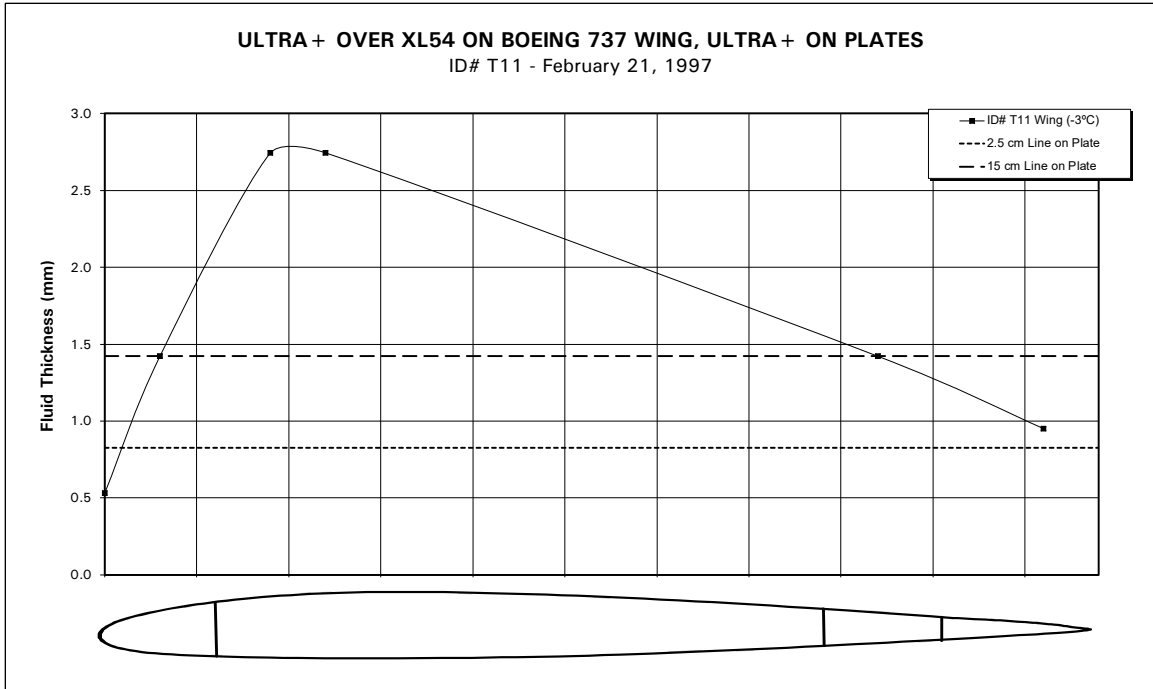


Figure 3.29: Type IV Fluid Thickness (Stabilized) Profile – No Precipitation

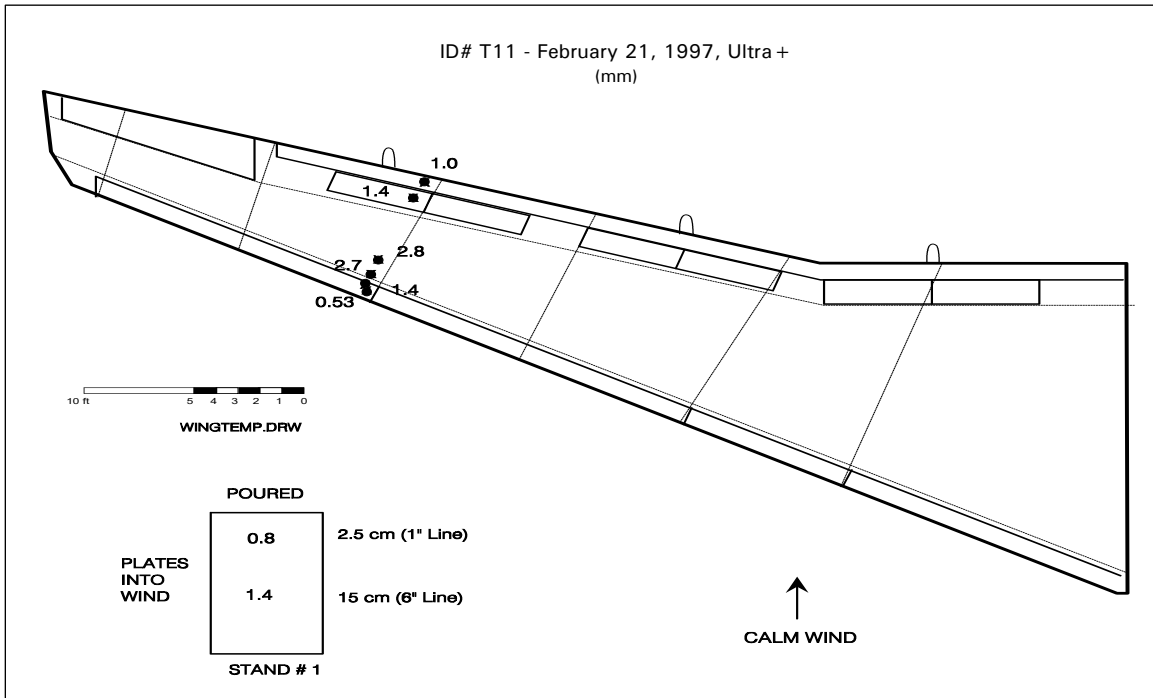


Figure 3.30: Boeing 737 Stabilized Thickness on Wing Plan

3.2.3.2 Fluid Thickness Tests on Propeller Aircraft

Figure 3.31 presents fluid thickness values measured at points laterally along the wing, at the highest point of the chord. These values are charted to show variance in thickness along the wing, and in the area affected by propeller wash. The inset provides a view of the wing plan identifying the measurement locations and the propeller wash zone. This figure provides results for trials T7 and T8, using Type I fluid.

Figure 3.32 is a similar presentation for trial T10, using Type IV fluid.

Data were also organized in graphical form to show a profile across a wing chord outside the area blown by propeller wash, and fluid thickness at reference points on a wing plan form similar to the treatment for the jet aircraft. Complete sets of these charts for all tests on propeller aircraft are provided in Appendix E.

In the course of trials on the DHC Dash 8 aircraft with the Department of National Defence at Winnipeg, it was observed that the applied fluid (Military Type I) very quickly ran off the wing surface, leaving very little fluid to measure. The small amount of fluid remaining was in the form of beads, similar to water beads on a waxed surface (see Photo 3.1). Discussions with local personnel determined that a water repellent fluid (Ice Ex II; produced by BFGoodrich, Ohio) had been applied to the wing leading edge to inhibit in-flight ice formation. A film of this fluid appeared to exist over the entire wing, perhaps due to migration rearward, or application beyond the leading edge. No usable fluid thickness data were gathered for these trials.

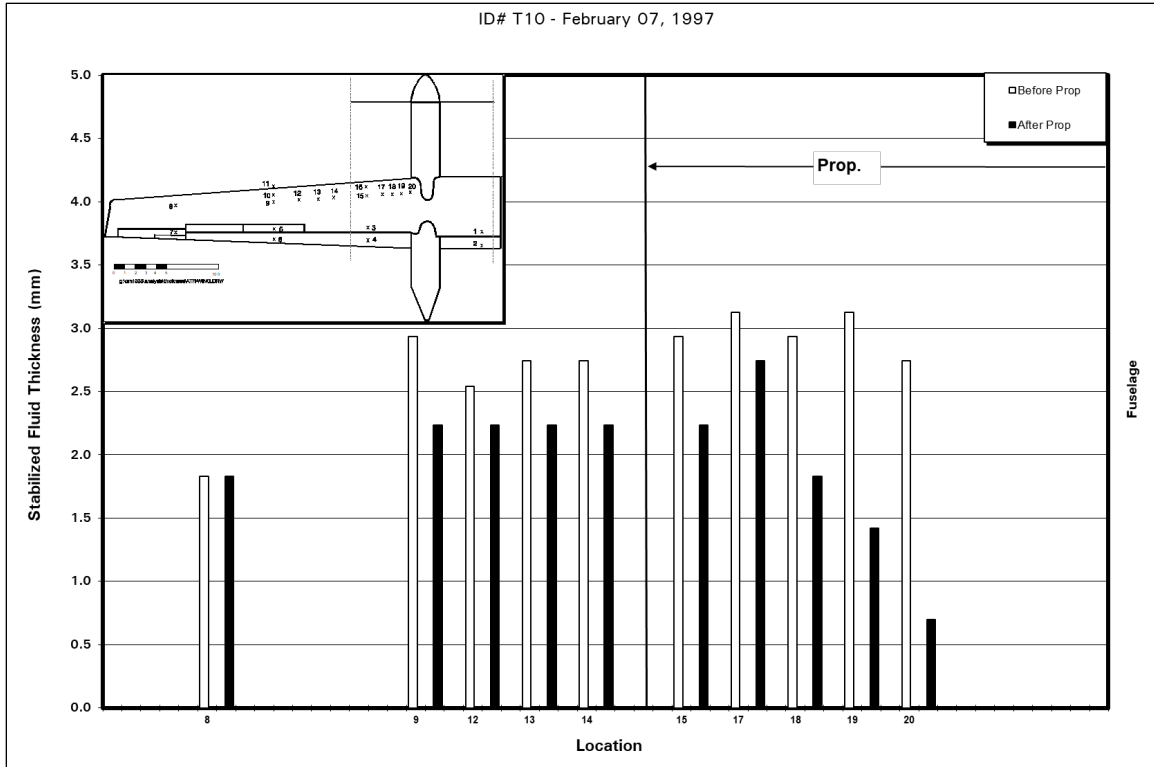


Figure 3.31: ATR 42 Turboprop Stabilized Fluid Thickness – Type I Fluid

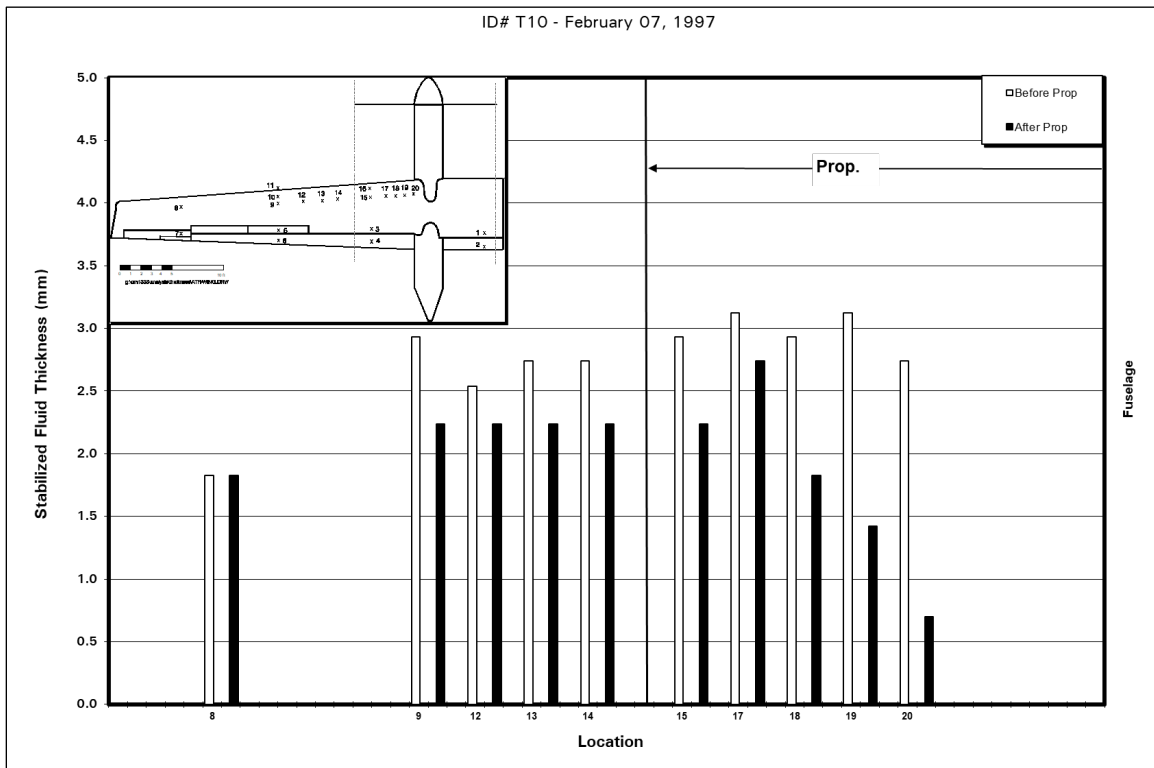


Figure 3.32: ATR 42 Turboprop Stabilized Fluid Thickness – Type IV Fluid

3.2.3.3 Fluid Application Trials at Mirabel

The principal documentations of these trials were in the form of photographic and video records of fluid application and the resulting fluid film using a variety of delivery nozzles, and following different application procedures.

This documentation was supported by graphical presentations of fluid thickness profiles across wing chords, enabling objective comparisons of the results of different trials.

The results of these trials were assembled in overhead transparency and video format for presentation to airline operators, fluid manufacturers, the Society of Automotive Engineers (SAE) G 12 meetings, and the Standing Committee on Aircraft Operations in Canada. In response to viewer requests subsequent to presentation of the video, copies have been provided to a number of carriers, ground handlers, and fluid and equipment suppliers.

A description of photos and thickness graphs for each trial follows.

3.2.3.3.1 Test ID T18 Nepiro Nozzle – Standard Operation

Photo 3.2 shows fluid on the wing after settling for 20 minutes. Figure 3.33 shows the fluid thickness profile on the chord of the wing for this application. The Nepiro Type II nozzle is shown in Photo 2.24.

3.2.3.3.2 Test ID T19 Akron Nozzle – Standard Operation

Photo 3.3 and Photo 3.4 show fluid being sprayed with the Akron Type I nozzle, and Photo 3.5 and Photo 3.6 show the film of fluid on the wing. Note the differences between fluid streams and elevations of the applicator in either photo. Figure 3.34 shows the fluid thickness profile on the chord of the wing for this application.

3.2.3.3.3 Test ID T20 Elephant B Standard Nozzle – Adjusted to a Narrow Stream

This nozzle can be adjusted from a fan of about 45° to a very narrow stream which enables reaching more distant areas on the aircraft. In this test, the fan was adjusted to a narrow stream to simulate a fluid spray by a hand-held nozzle using a narrow spray pattern. Photo 3.7 and Photo 3.8 show fluid being sprayed with a reduced fan pattern and with a narrow stream, and Photos 3.9 and Photo 3.10 show the film of fluid on the wing. Figure 3.35 shows the fluid thickness profile on the chord of the wing for this application, compared to the profile for the Akron nozzle application.

3.2.3.3.4 Test ID T21 Elephant β Optional Nozzle – Standard Operation

This nozzle delivers fluid in a fixed 45° pattern and at a lower fluid flow than the standard nozzle. Photo 3.11 shows fluid being sprayed with this nozzle, and Photo 3.12 shows the film of fluid on the wing. Figure 3.36 shows the fluid thickness profile on the chord of the wing for this application, compared to the profile for the Akron nozzle application.

3.2.3.3.5 Test ID T22 Elephant β Optional Nozzle – Continuous Spraying to Achieve Maximum Thickness of Fluid Film

Spraying was repeated with the optional nozzle until fluid measurements confirmed that maximum thickness had been reached. Photo 3.13 shows fluid being sprayed with this nozzle, and Photo 3.14 shows the film of fluid on the wing. Figure 3.37 shows the fluid thickness profile on the chord of the wing for this application, compared to the profiles for the previous optional nozzle application and the Akron nozzle application.

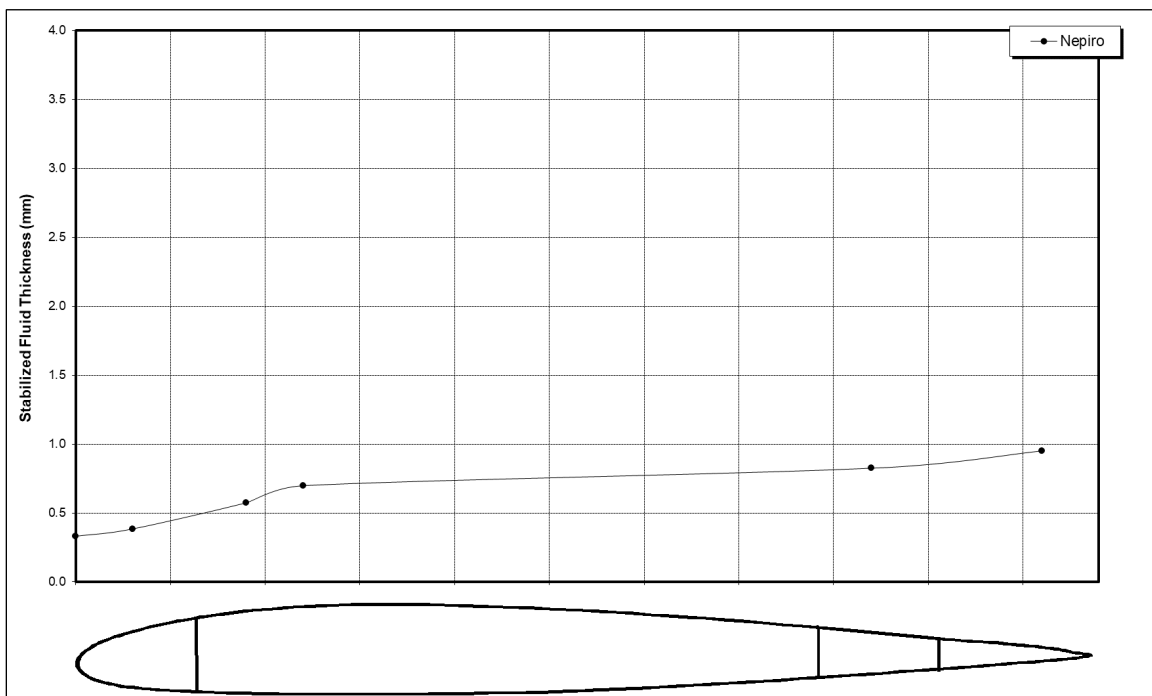


Figure 3.33: Fluid Application Trial – Nepiro Nozzle – Standard Operation
Ultra + Over XL54, T18 – April 09, 1997

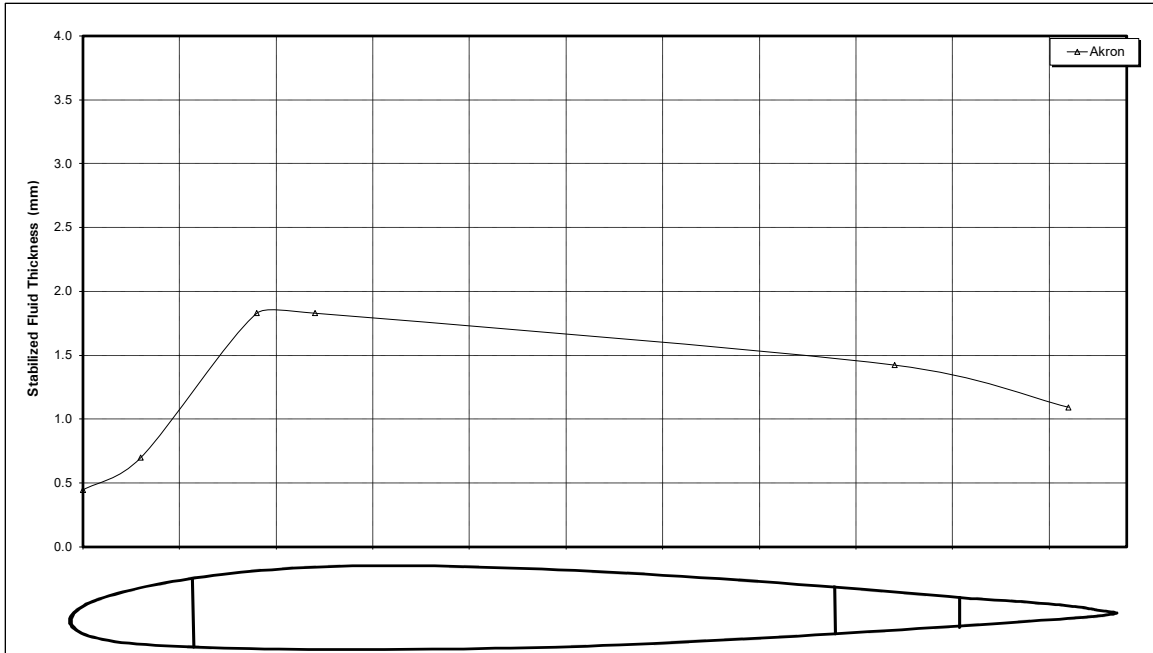


Figure 3.34: Fluid Application Trial – Akron Nozzle – Standard Operation
Ultra + Over XL54, ID# T19 – April 09, 1997

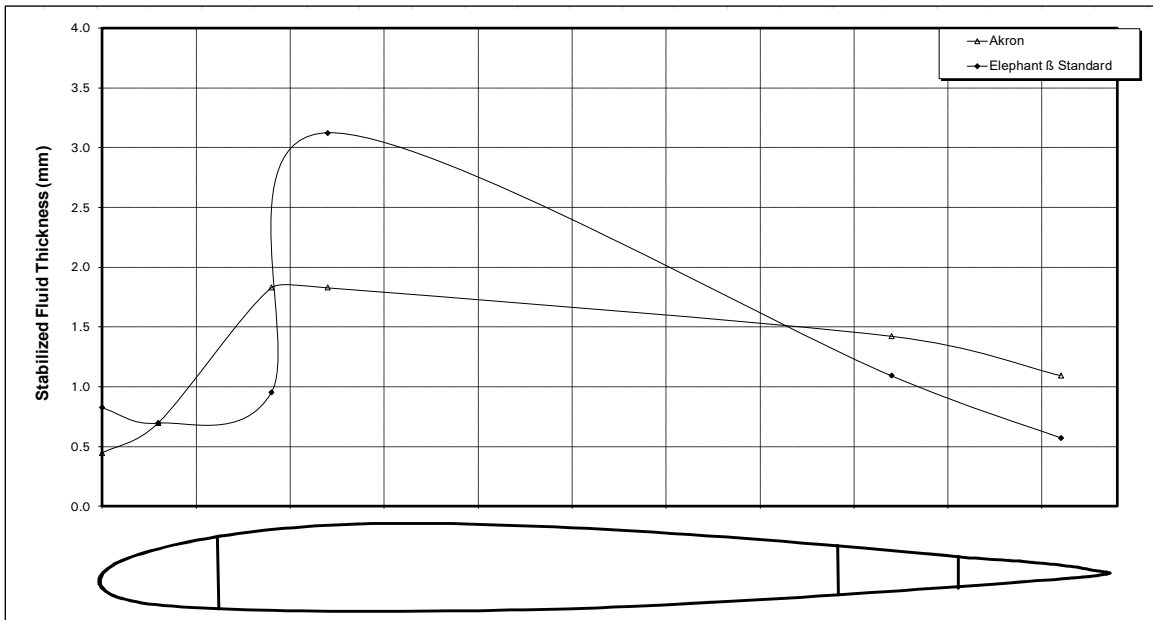


Figure 3.35: Fluid Application Trial – Elephant β Standard Nozzle – Narrow Stream
Ultra + Over XL54, ID# T20 – April 09, 1997

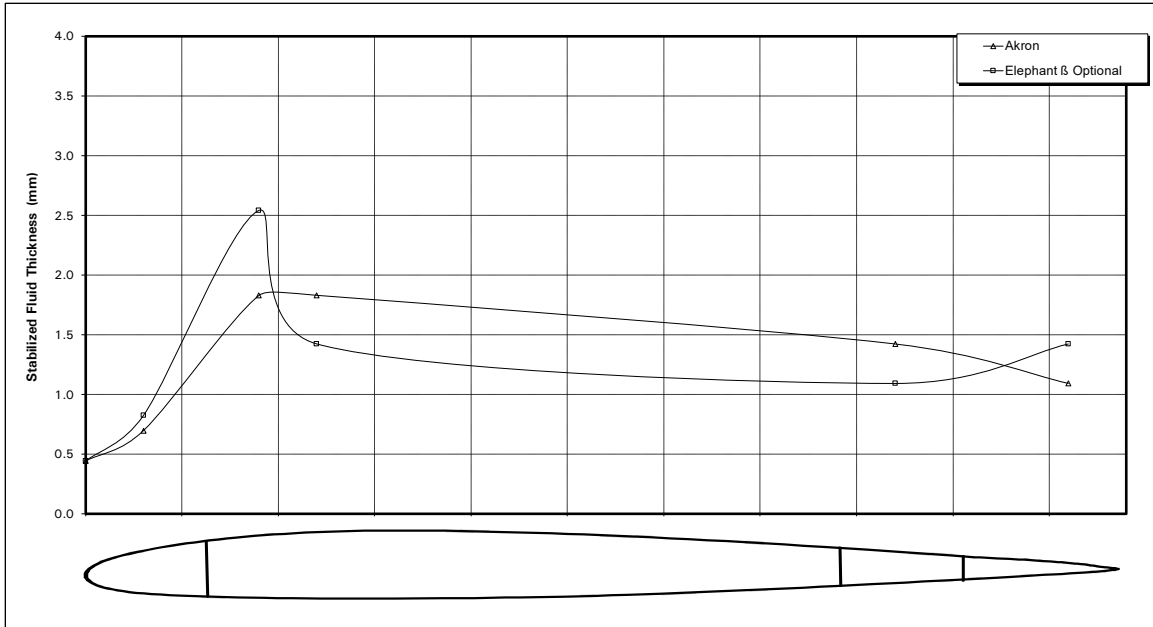


Figure 3.36: Fluid Application Trial – Elephant & Optional Nozzle – Standard Operation
Ultra + Over XL54, ID# T21 – April 09, 1997

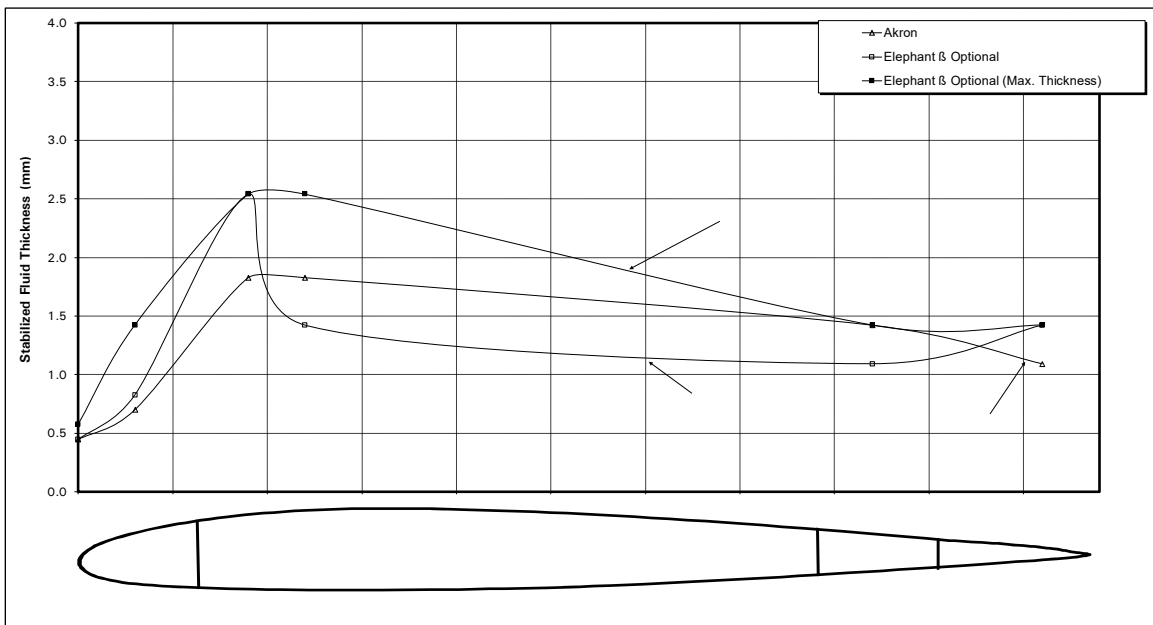


Figure 3.37: Fluid Application Trial – Elephant & Optional Nozzle – Continuous Spray for Maximum Thickness
Ultra + Over XL54, ID# T20 – April 09, 1997

3.2.4 Description of Photos and Video

Photographic and video records were produced for all trials, showing the test setup, test in progress and results. Only some of the resultant photos are included in this report. A full library of photographic and video records of all tests is maintained and is available for reference.

A video presentation of Type IV fluid application was prepared. This video has been presented at industry meetings and copies have been distributed to a number of airlines, ground handlers, and fluid and equipment manufacturers for their information, and for use in the training of deicing personnel.

Photo 3.1: Fluid Beading on a DHC Dash 8 Wing



Photo 3.2: Nepiro Nozzle – Type IV Fluid After 20 Minutes



Photo 3.3: Akron Type I Nozzle – Type IV Fluid Application on Leading Edge



Photo 3.4: Akron Type I Nozzle – Type IV Fluid Application Over Wing



Photo 3.5: Akron Type I Nozzle – Type IV Fluid on Leading Edge



Photo 3.6: Akron Type I Nozzle – Type IV Fluid on Control Surfaces



Photo 3.7: Elephant β – Standard Nozzle – Adjusted to Reduced Pattern



Photo 3.8: Elephant β – Standard Nozzle – Adjusted to Narrow Stream



Photo 3.9: Elephant β – Standard Nozzle – Narrow Stream – Fluid on Leading Edge

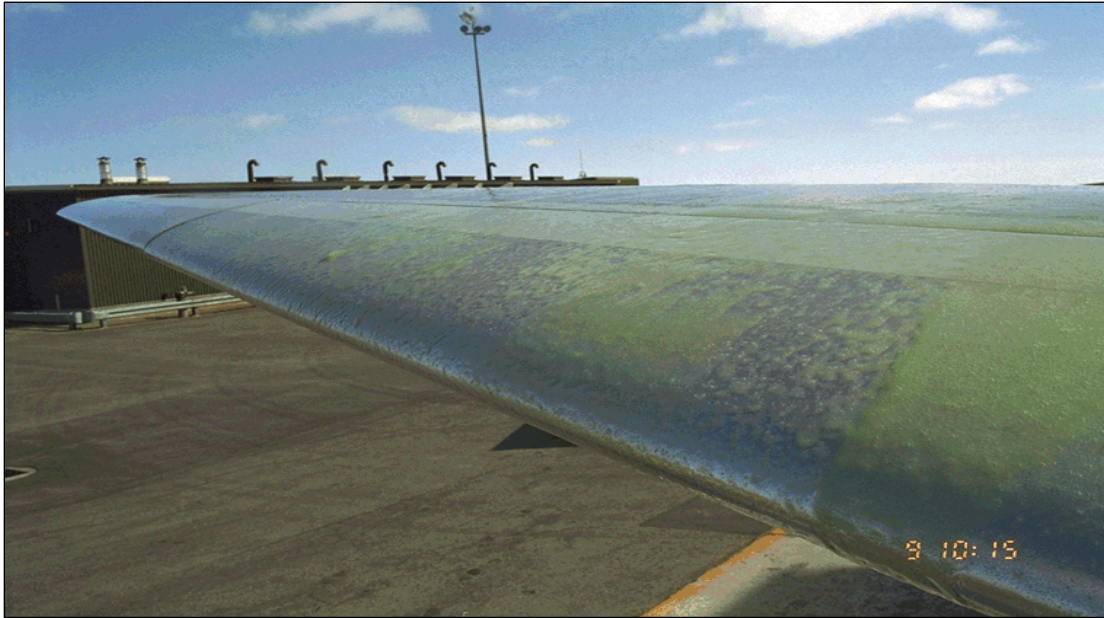


Photo 3.10: Elephant β – Standard Nozzle – Narrow Stream – Fluid on Control Surfaces

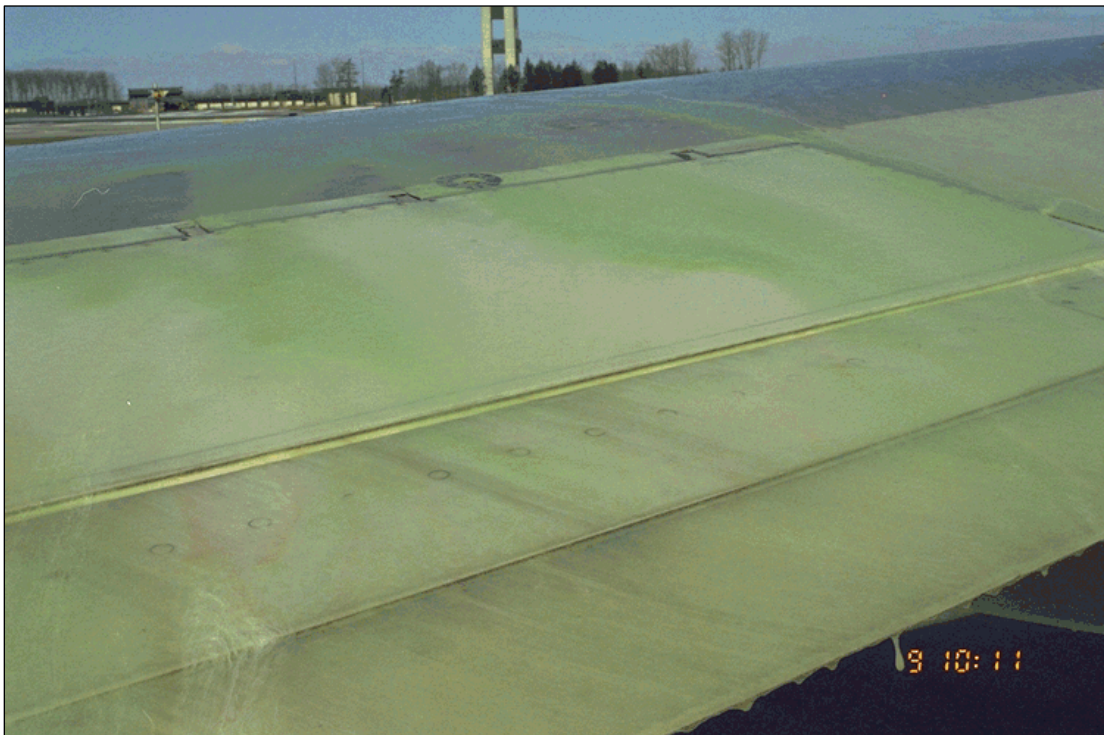


Photo 3.11: Elephant β – Optional Fixed Nozzle



Photo 3.12: Elephant β – Optional Fixed Nozzle – Leading Edge



Photo 3.13: Elephant β – Optional Fixed Nozzle – Ultimate Thickness Trial



Photo 3.14: Elephant β – Ultimate Film Thickness Trial



This page intentionally left blank.

4. ANALYSIS AND OBSERVATIONS

This section of the report will detail and analyse events that were observed during the course of testing, with results again being divided between fluid failure characteristics tests and fluid thickness tests.

4.1 Fluid Failure Characteristics

This section will provide a detailed analysis of observations that relate to the characteristics of fluid failure.

4.1.1 Progression Patterns of Failure

This section of the report examines and identifies the way in which a wing fails over time.

During the full-scale tests, observers were assigned to wings in order to map sequential failure contours within the duration of each test. A contour was drawn when the first observed failure was called, and subsequent drawings were made at regular time periods thereafter. Simultaneously, personnel took fluid samples and thickness measurements from predetermined points on the wing. Brix readings were then taken from these fluid samples. Precipitation rates and types were continually monitored, and video and photo records were developed for each session. For a more detailed description of this process, see Subsection 2.1.4.

4.1.1.1 Effect of Aircraft Type on The Pattern of Progression of Failure

This section examines the effect of aircraft type on the progression of failure. During the course of full-scale testing in 1996/97, tests were conducted on Boeing 737, Fokker 100 and ATR 42 aircraft. Tests from previous years were carried out on McDonnell Douglas DC-9, Airbus A320, Boeing 737, and BAe 146 aircraft. Progression of failure results from all of these different aircraft types will be compared in this section.

Boeing 737

Using all of the data and charts available from testing to date, the following observations related to the progression of failure on the Boeing 737 were made.

- First wing failures for the Boeing 737 are most likely to occur in the trailing edge outer section of the aileron. The next most probable area to fail is the leading edge mid-section along the leading edge joint (see Figure 3.18). The mid-sections have a very low probability of first failure occurrence.

- Wing 10% failures most commonly occurred on the leading edge and on the aileron, with the leading edge mid-section having the highest occurrence of failure (see Figure 3.22). The mid-sections of the wing are the least likely to be failed at wing 10% failure time.
- The leading edge and trailing edge sections are the first to achieve 100% failure, with the leading edge mid-section being the most likely to have complete contamination. The mid-wing sections are the last to fail completely (Figure 3.15).

The high occurrence of first failures on the aileron section of the Boeing 737 can probably be attributed to the fact that the fluid flow to the trailing edge is dissipated via discontinuities in the aileron structure. Furthermore, the reservoir of fluid available to feed into this area is reduced, since the wing is narrower near the wing tip. The steep wing dihedral, which encourages the fluid to flow away from the outer wing sections is another possible factor accounting for the high occurrence of failure at this location.

The leading edge mid-section also has a high probability of first failure. This probably occurs as a result of the reduced fluid flow, caused by the discontinuities associated with the slats on the leading edge and the thin film which remains in this area.

In crosswind conditions, the upwind and downwind wings failed differently. The trailing edge outer section of the downwind wing failed first, whereas the trailing edge inside section of the upwind wing failed first. Failure times were also quicker on the downwind wing. Due in large part to the dihedral of the wing, the downwind wing is angled across the wind, while the upwind wing is angled into the wind. As a result, the downwind wing will likely experience a higher precipitation rate since it has a larger cross section in the wind. Further discussion of the effects of crosswind conditions is provided in a later section.

Fokker 100

The progression of failure results for the Fokker 100 tests were significantly different.

- In every test, first wing failures occurred on the aileron in the trailing edge outer section. The spoilers (trailing edge inner and mid-sections) were the next most likely sections to fail (see Figure 3.16 and Figure 3.17). The aircraft mid and leading edge sections were the least probable to experience initial wing failure.
- When wing failures reached the 10% level, failures were always present on the aileron and spoilers of the trailing edge. Failures in the mid and leading edge sections at 10% wing failure time were less likely.
- The trailing edge sections are most likely to reach 100% failure first, with the trailing edge inner section likely to be the first section to fail. The leading edge sections fail next, followed by the mid-sections.

The high occurrence of first failure on the ailerons and spoilers in Fokker 100 tests can be attributed to the discontinuities associated with the spoilers and ailerons, which inhibit fluid flow. The leading edge sections of the Fokker 100 reached first failure (and subsequent failures) later than was initially expected. It may be that fluid is able to flow over this section, feeding fluid from the top, since the leading edge is without moveable surfaces which would normally impede fluid flow. This observation could be supported further by conducting thickness measurements over chords of the Fokker 100.

Upwind and downwind wings in Fokker 100 crosswind tests show no appreciable differences in the progression of failure. However, the time of failure of the two wings is different (to be discussed in Subsection 4.1.1.2). This is probably due to the shallow dihedral of the Fokker 100 wing.

McDonnell Douglas DC-9

Progression of failure observations were made based on McDonnell Douglas DC-9 tests from previous years.

- First failure is most likely to occur on the aileron, followed by the outer leading edge section. Mid-wing sections are the least likely to experience first failures.
- Wing 10% failures most commonly occur on the leading edge outer section, followed by the aileron on the trailing edge. In general, 10% failures rarely occur in the mid-wing sections and are normally situated on the leading or trailing edges (Figure 3.23).

BAe 146 and Airbus A320

Four tests on BAe 146 and two tests on Airbus A320 aircraft were performed during the course of the 1994/95 test season. The test methodology, used in previous fluid failure trials, has since been refined. The first failure results of these tests are shown in Figure 3.20. First failures developed on the BAe 146 outer wing sections in all tests. Airbus A320 first failures occurred on the wing tip and spoilers in one test, and on the spoilers in the other.

ATR 42

Three tests were conducted on ATR 42 aircraft in 1996/97, one in a headwind condition, and two others in crosswind conditions. In the headwind condition, the leading edge failed first, followed by the trailing edge, while the crosswind tests were inconclusive, due to the rapid progression of failure which did not allow for proper observations to be made.

Comparison of Aircraft Types

Since it is believed that aircraft with comparable wing designs should have similar progressions of failure, aircraft were also grouped by wing characteristics for the purpose of certain comparisons. The wing characteristics of the different aircraft used for testing are shown in Table 2.1.

Tests were conducted by APS Aviation on the McDonnell Douglas DC-9 (1994/95) and Boeing 737 (1994/95 and 1996/97). These two aircraft have comparable wing design characteristics: as well as being similar in wing span, wing area and wing sweep, both wings contain leading edge slats, and have similarly located trailing edge flaps, ailerons, and spoilers. However, the dihedral on the McDonnell Douglas DC-9 is less pronounced than it is on the Boeing 737.

Two sets of McDonnell Douglas DC-9 and Boeing 737 tests were compared. In the first comparison, Run # 1 from 1995/96 (McDonnell Douglas DC-9) and ID # 24 from 1996/97 (Boeing 737) were used. Both tests were conducted using Type IV fluids in light freezing rain conditions. The precipitation rates, temperatures, and wind directions were similar in both tests. The wind was slightly stronger, however, in Run # 1 (ID # 24 wind was listed as calm). First failures occurred on the leading edge near the wing tip for the McDonnell Douglas DC-9 test, and on the aileron for the Boeing 737. At 10% wing failure, both aircraft had similar patches of failed areas on the leading edge. The Boeing 737 also had failures on the aileron and spoiler sections on the trailing edge.

The other set of tests used for comparison was ID # T4, Run # 4 (McDonnell Douglas DC-9) and ID # Z1 (Boeing 737). Both tests were conducted in 1994/95. Both tests were conducted in snow conditions with similar wind directions and rates of precipitation, with wind speeds being higher in ID # T4. In both cases, first failure occurred on the mid-wing leading edge.

The failure occurrence charts (Figure 3.17 to Figure 3.19 and Figure 3.21 to Figure 3.23) indicate that wings of similar design fail in the same manner. First failure charts for the Boeing 737 and McDonnell Douglas DC-9 tests (Figure 3.18 and Figure 3.19) show that both aircraft have high occurrences of first failure on both the leading and trailing edges. The charts for the same aircraft at 10% failure (Figure 3.22 and Figure 3.23) also depict high occurrences of failure on both the leading and trailing edges. The Fokker 100 occurrence of failure charts (Figure 3.17 and Figure 3.21) indicate that failures were limited primarily to the trailing edge.

This section confirms that aircraft type, and more particularly wing design, do effect the progression of failure. Aircraft with moveable surfaces on the leading edge, such as the Boeing 737 and the McDonnell Douglas DC-9, experience failures on both the leading and trailing edges due to the discontinuities caused by the surfaces in each

of the wing sections. Aircraft with hard wing designs, such as the Fokker 100, exhibit mostly trailing edge failures, because no discontinuity exists on the leading edge to disrupt the fluid flow. This is apparent in Figure 3.24, which illustrates the percentage of leading edge failure when failures on the wing reach the 10% level. For Boeing 737 tests, the percentage of leading edge failure at this point is high, whereas with the Fokker 100 tests, the percentage of leading edge failure is low or non-existent.

4.1.1.2 Comparison of Upwind and Downwind Wings in Crosswind Conditions

In this section, the results of upwind wing and downwind wing fluid failure progression are compared. During the course of full-scale testing in 1996/97, five sets of crosswind cases exist where the two aircraft wings were tested simultaneously:

Test sets:

ID # 3, 4	Boeing 737
ID # 5, 6	Boeing 737
ID # 9, 10	Boeing 737
ID # 32, 33	Fokker 100
ID # 34, 35	Fokker 100

Test set ID # 3, 4 was halted early in the test because the aircraft had to be returned to the operator and, as a result, failures had not progressed past the stage of early contamination on either wing. For this reason, Test set ID # 3, 4 was not used in this comparison.

In order to compare the failure patterns and times of upwind and downwind wings, the percentage of fluid failure by wing section charts, the 10% wing failure contours, and the individual failure contour drawings for each test were examined. It was observed in all cases that the downwind wing failed more rapidly than the upwind wing. In fact, the downwind wing reached 10% failure on average, twice as quickly as the upwind wing. In two test sets (ID # 5 and 6, and ID # 34 and 35), the rates of precipitation during tests on the downwind wings are lower than those on the upwind wings, however the downwind wings still failed earlier. One possible explanation for this occurrence is that snow from the upwind side, or which has accumulated on the upwind side of the fuselage, is being blown over the fuselage and onto the downwind wing. Figure 4.1 shows an example (ID # 32 and 33) of the progression of failure of upwind and downwind wings. The general conditions for these tests are listed below:

ID # 32 (Downwind)
Mar 6, 1997 – Run # 4
American Fokker 100
Port Wing, Dorval Airport

OAT: 4.1°C
Wind Orientation: Crosswind (Downwind)
Wind Direction: 51°
Wind Speed: 20 kph
Precipitation Type: Snow
Aircraft Direction: 310°
HOT Start: 3:24 AM
Type I Fluid: XL54
Type IV Fluid:

ID # 33 (Upwind)
Mar 6, 1997 – Run # 5
American Fokker 100
Starboard Wing, Dorval Airport

OAT: 4.2°C
Wind Orientation: Crosswind (Upwind)
Wind Direction: 51°
Wind Speed: 20 kph
Precipitation Type: Snow
Aircraft Direction: 310°
HOT Start: 3:27 AM
Type I Fluid: XL54
Type IV Fluid:

The tests were started three minutes apart, which is the time required for the spray vehicle to spray the first wing and travel to the second wing. Figure 4.1 clearly shows that the downwind wing failed before the upwind wing.

Related tests were done on both the Boeing 737 and Fokker 100, and downwind wings always failed prior to upwind wings for both aircraft. Failure patterns for the Boeing 737 show that the trailing edge outer section of the downwind wing failed first, while the trailing edge inner section of the upwind wing failed first. In general, the outer sections of the downwind wing tend to fail before the inner and mid-sections. For the upwind wing, the inner sections fail prior to the mid and outer sections. A schematic of the increase in the effective precipitation rate on the downwind wing in crosswind conditions for aircraft such as the Boeing 737 is shown in Figure 4.2. This increase in precipitation rate, and subsequent earlier wing failure, is due to the effect of snow fencing and the increased catch rate of the downwind wing caused by the dihedral.

There is no appreciable difference in the progression of failure when comparing the upwind and downwind wings of the Fokker 100. In all cases, the first failure occurs on one of the trailing edge sections, on either the ailerons or spoiler panels.

Tests were conducted in crosswind conditions using both Type I and Type IV fluids, and results show that the fluid type did not affect the failure progression patterns.

It can be concluded from the results in this section that downwind wings fail prior to upwind wings in crosswind conditions. For the Boeing 737, the outer section of the wing fails first for the downwind wing, and the inner section of the wing fails first for the upwind wing. Fokker 100 aircraft wings do not fail in the same manner, and failures are not very different in upwind or downwind conditions, perhaps due to the shallower dihedral.

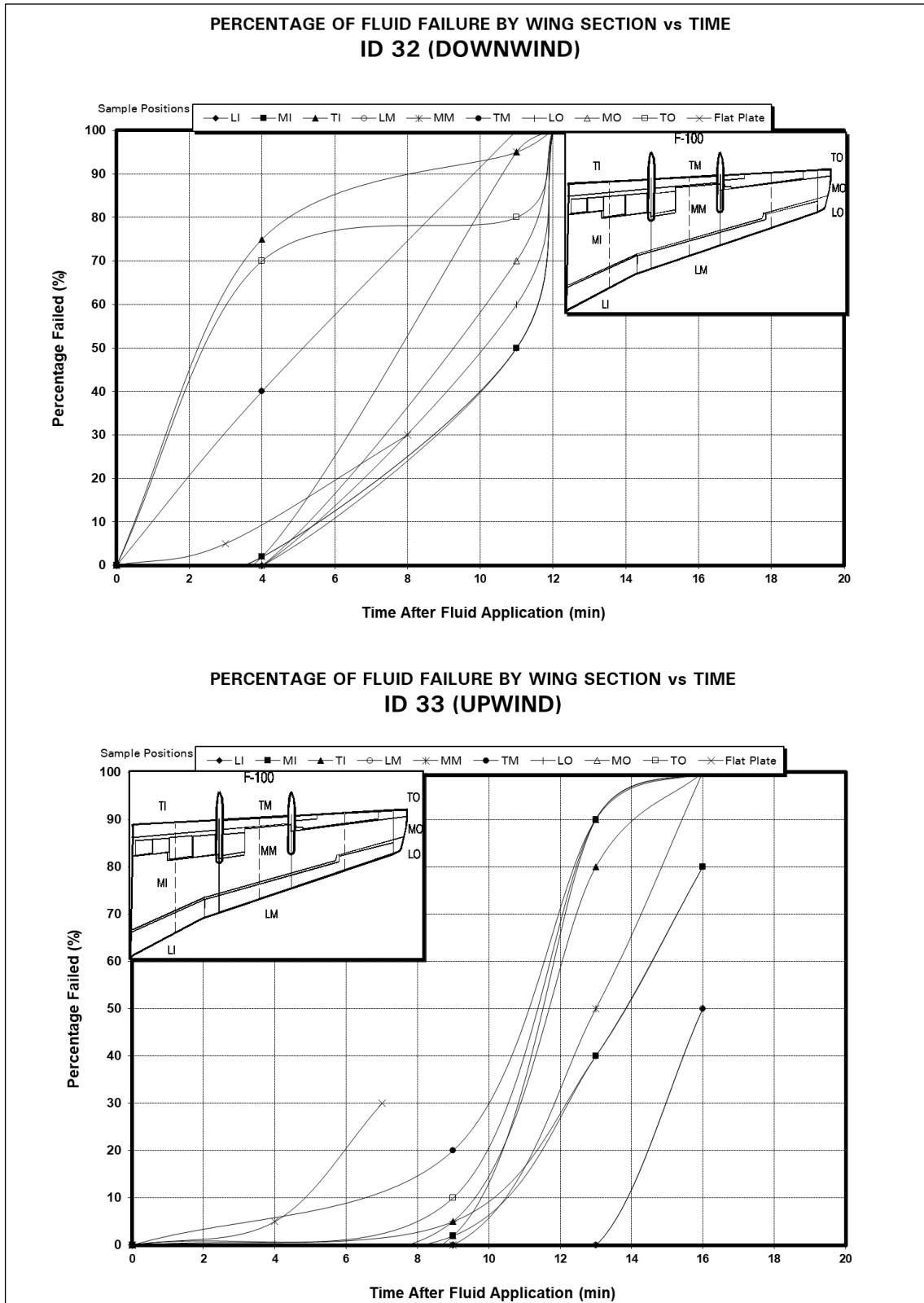


Figure 4.1: Example of the Progression of Failure of Related Downwind and Upwind Wing

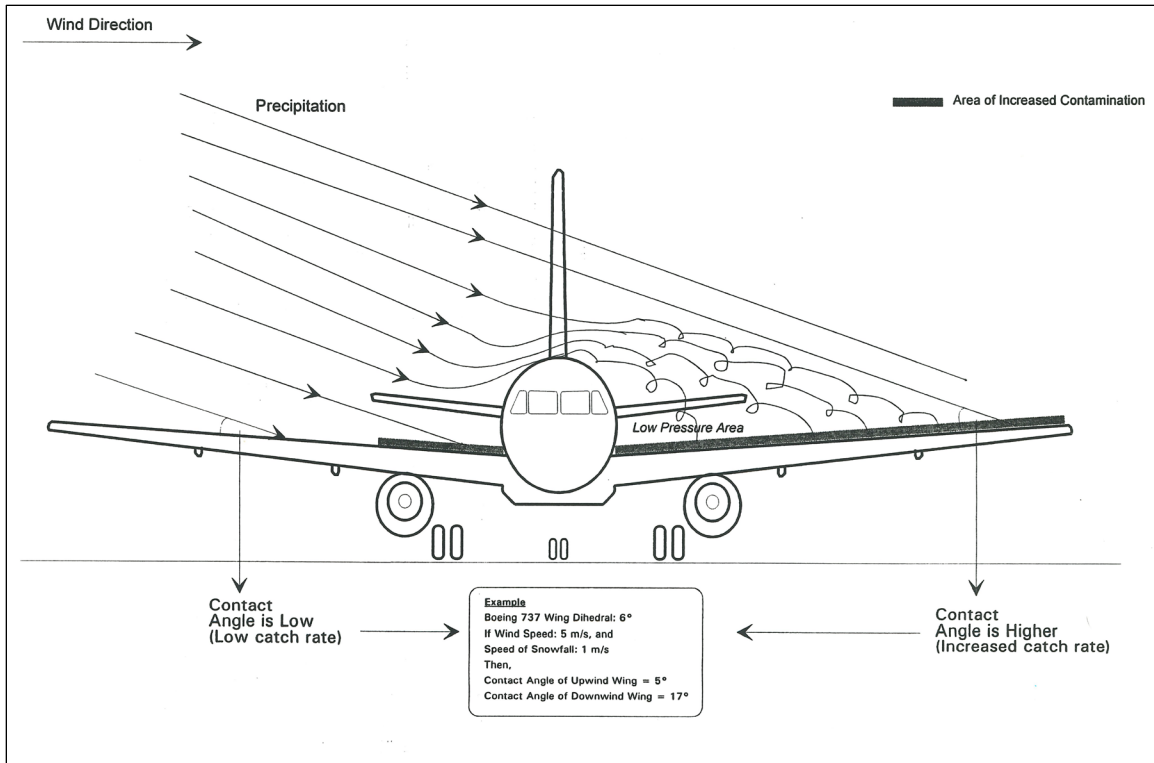


Figure 4.2: Increase in Effective Precipitation Rate Due to Crosswind

4.1.1.3 Comparison of Headwind and Tailwind Conditions

In this section, the effects of headwind and tailwind conditions on the progression of fluid failure on different aircraft wings are examined. Tests used in this comparison include Boeing 737 and Fokker 100 full-scale tests from 1996/97, and one Boeing 737 test from 1994/95 (ID # Z1).

The tests were grouped into sets based on wind direction, aircraft type, and fluid type. Since it is not possible to control the conditions under which full-scale tests are performed, some of the tests used in this comparison have different wind speeds, temperatures and precipitation rates. No Boeing 737 tests were conducted in 1996/97 in headwind conditions. As a result, one Boeing 737 test (ID # Z1) from 1994/95 was used to compare Type I fluid results for this aircraft type. No testing from previous years was performed using Type IV fluid on Boeing 737 aircraft, and as a result no comparison of headwind and tailwind failure patterns is possible for this aircraft and fluid type. Three sets of related tests were chosen for analysis, and included for each is the ID #, aircraft type, wind condition, fluid type, temperature, rate of precipitation, and the wind speed:

Test Sets

ID # 15	Boeing 737	Tailwind	Type I	4°C	11 g/dm ² /hr	11 kph
# Z1	Boeing 737	Headwind	Type I	0°C	17 g/dm ² /hr	4 kph
ID # 22	Fokker 100	Tailwind	Type I	1°C	15 g/dm ² /hr	9 kph
# 31	Fokker 100	Headwind	Type I	4°C	8 g/dm ² /hr	17 kph
ID # 19	Fokker 100	Tailwind	Type IV	2°C	22 g/dm ² /hr	7 kph
# 29	Fokker 100	Headwind	Type IV	4°C	8 g/dm ² /hr	17 kph

Failure drawings of the Boeing 737 Type I tests revealed that first wing failure occurred on the aileron for the tailwind condition (ID # 15), and on the mid-leading edge for the headwind condition (ID # Z1). Failures at the 10% wing failure time for the tailwind test had progressed to include the entire aileron and parts of the different flap sections on the trailing edge, as well as some leading edge failure. 10% wing failure for the headwind condition looked very similar to that of the tailwind condition.

Failure drawings of the Fokker 100 Type I tests show that first wing failures occurred on the aileron in the tailwind condition (ID # 22), and on the wing joints of the leading edge, the aileron and spoilers in the headwind condition (ID # 31). Ten percent failure patterns in both conditions looked similar, with failures located on the spoilers, ailerons and flaps. Patches of failure on the leading edge were present only on the headwind wing at 10% wing failure.

Comparison of the Type IV Fokker 100 tests show that failure patterns were similar to those of the Type I tests. First failure location in the tailwind test (ID # 19) was situated on the aileron. In the headwind test (ID # 29), first failure occurred on the wing joints on the leading edge and the aileron. 10% failure patterns in both conditions were nearly identical, with failures being present on the flaps, spoilers and ailerons, as well as some leading edge failure at the wing joints.

The results of these comparisons show that first failure locations of tests conducted in tailwind and headwind conditions are different. In tailwind conditions, first wing failure occurs on the trailing edge. In headwind conditions, leading edge failure is always present (see Figure 3.16) at wing first failure times, demonstrating that there is likely an increase in precipitation impinging on the leading edge which is probably caused by the geometry of the nose. Failures seem to progress similarly following first failure, regardless of the wind direction. It should be noted that failure times of the different tests in headwind and tailwind conditions were not compared because the rates of precipitation for the tests were not similar; a comparison using first failure and 10% failure contours was considered to be more representative.

4.1.1.4 Effect of Wind Speed on The Pattern of Progression of Failure

To study the effects of wind speed on the progression of fluid failure, APS Aviation attempted to group together full-scale tests with the same aircraft type, fluid type, wind direction, and precipitation type, but with different wind speeds. Unfortunately, no related tests were performed in the 1996/97 test season. A review of tests from previous years was also conducted, but once again, no related tests could be found. The lack of related tests is due to the fact that full-scale tests are conducted in natural precipitation and, as a result, conditions cannot be controlled. The effect of wind speed on failure progression was not determined.

Based on crosswind comparison, it may be expected that under high wind speed conditions, failures on the downwind wing would be faster. In conditions when the wing leading edge is pointed into the wind, failures on the leading edge may be accelerated in high wind condition due to the increased precipitation impinging on the nose, particularly if the wing has leading edge slats which could prevent feeding of the fluid from the top of the wing.

4.1.1.5 Effect of Precipitation Type on The Pattern of Progression of Failure

Full-scale tests conducted in various conditions were examined in order to determine the effects of precipitation type on the progression of wing failure. Tests were performed during the course of the 1996/97 test season in snow, light freezing rain and a mixture of snow and ice pellet conditions. Holdover time ranges do not exist for ice pellet conditions, due in part to the difficulty in determining ice pellet failures. As a result, tests conducted in this condition were ignored for the purpose of the study related to the effect of precipitation type.

Two tests, ID # 13 and 24, were both conducted on Boeing 737 aircraft with Type IV fluid. ID # 13 took place in natural snow conditions, while ID # 24 occurred in light freezing rain. The rates of precipitation, test temperatures and wind speeds were similar. First wing failure on both occasions occurred on the aileron. The 10% wing failure contours of both tests looked alike. Failure patterns continued to progress beyond 10% failure on both wings in similar fashion, and resembled each other at the end of the tests. The only difference was the speed in which the two failures progressed. The light freezing rain test reached first failure, 10% and 25% wing failure in less than half the time of the snow test (the rate was slightly higher in ID # 24). This comparison shows that the dilution of fluid is a more efficient process in liquid precipitation and therefore results in shorter failure times than for the case of solid precipitation, such as snow.

Two Type I tests conducted on the Boeing 737 were also compared. ID # 15 and ID # 25 were performed, respectively, in snow and light freezing rain conditions.

Failure progressions of both tests were similar. The first failure location in both tests was on the aileron. The wing failure contours at 10% and 25% wing failure are also alike. Contrary to the Boeing 737 Type IV comparison, failures progressed more rapidly in snow than in light freezing rain (the rate was higher in the freezing rain test).

A Type IV test conducted on a McDonnell Douglas DC-9 aircraft in light freezing rain conditions (Run # 2, 1995/96) was compared to a previous snow test (ID # L7, 1994/95) on the same aircraft. Failures up to the 10% wing failure time in Run # 2 were exclusively located on the leading edge, while failures in ID # L7 were present on the leading and trailing edges. It should be noted, however, that the fluid application in ID # L7 was deemed to be inadequate. No McDonnell Douglas DC-9 Type I tests were conducted in freezing rain conditions, and as a result, no effect of precipitation type study was done for this aircraft and fluid type.

These comparisons of the effect of precipitation type on the progression of failure are inconclusive. They do show, however, that failures progress at different speeds in certain types of precipitation.

4.1.1.6 Effect of Precipitation Rate on The Pattern of Progression of Failure

This section examines the effect of rate of precipitation on the progression of fluid failure. Two sets of similar tests conducted in snow with different rates of precipitation, were chosen for this comparison. The conditions of each test are shown below:

Test ID #	Aircraft Type	Fluid Type	Wing Orient.	Wind Speed	Outside Air Temp.	Precipitation First	Rate 10%	(g/dm ² /hr) 25%	Wing First	Failure 10%	Time (min) 25%
15	B-737	I	Tail	11 kph	-5°C	12	11	11	6	9	14
16	B-737	I	Tail	11 kph	-4°C	12	24	30	4	7	10
29	F-100	IV	Head	17 kph	-4°C	6	8	8	27	73	88
35	F-100	IV	Cross	20 kph	-5°C	31	38	38	13	36	41

Tests ID # 15 and ID # 16 were conducted with Type I fluid, while tests ID # 29 and ID # 35 used Type IV fluid. The failure progression patterns of the two sets of related tests were similar. The wing first failure locations were almost identical. Wing 10% and 25% failure patterns were also similar. The only difference in the progression of failure was the speed in which the failures occurred. Tests ID # 16 and ID # 35 had higher rates of precipitation than their related tests and, as a result, reached first failure, 10% and 25% wing failure prior to the other tests.

The results of these comparisons show that the rate of precipitation has no effect on the location of first failure and the pattern of failure progression. The rate of failure propagation, however, is directly effected by the rate of precipitation.

4.1.1.7 Effect of Temperature on The Pattern of Progression of Failure

A review of all full-scale tests from 1994 to 1997 revealed that no tests were conducted in similar conditions with significant temperature differences. As a result, the effect of temperature on the progression of failure has not been determined. Intuition suggests that (all other factors being equal) lower temperatures cause failures to occur scanner, but the pattern of failure progression may not be effected.

Although the effects of temperature on the progression of failure were not determined, the appearance of fluid failure does change with temperature. For further discussion on this topic, refer to Subsection 4.1.5.

4.1.1.8 Effect of Fluid Type on The Pattern of Progression of Failure

This section examines the effects of fluid type on the progression of failure. During the course of full-scale aircraft testing, Type I and Type IV de/anti-icing fluids were used. Two sets of tests conducted in similar conditions, using different fluid types, were chosen for this comparison. The conditions of each test are shown below:

Test ID #	Aircraft Type	Fluid Type	Wing Orient.	Wind Speed	Outside Air Temp.	Precipitation First	Rate 10%	(g/dm ² /hr) 25%	Wing First	Failure 10%	Time (min) 25%
13	B-737	IV	Tail	11 kph	-4°C	36	101	126	21	14	17
14	B-737	I	Tail	11 kph	-5°C	4	6	7	21	21	21
19	F-100	IV	Tail	7 kph	-2°C	7	31	51	21	22	22
20	F-100	I	Tail	7 kph	-2°C	5	9	12	23	23	20

Failure progressions of the four tests were compared, using the failure contour drawings and 10% wing failure depictions. Initial failure locations were similar in each set of tests, as were the 10% failure patterns. Failures progressed much more quickly in the Type I tests than the Type IV tests.

In order to determine the condition of the wing five minutes after first failure, the progression of failure drawings for Type I and Type IV tests were examined. For Type IV tests, it was found that there were no substantial differences between the condition of the wing at first failure, and five minutes after first failure. For Type I

tests, however, wings were on average 40% failed five minutes after first failure. Therefore, early detection of Type I failure is far more critical than in the case of Type IV failure, due to the rapid progression of failure of Type I fluid.

Type IV full-scale tests were performed in 1996/97 using exclusively Union Carbide Ultra + fluid. It is difficult to predict how fluids other than Ultra + would perform and behave on aircraft wings, since no other fluid was tested. Inadequate Type IV fluid applications do occur. The progression of failure on aircraft wings would probably change for fluids which flow differently, since they would provide more complete coverage, even in the event of an inadequate fluid application. Fluid manufacturers such as Octagon claim that their Type IV fluid does flow better than others, but documentation or test results that confirm this claim are not available.

Results from this section show that fluid type has little or no effect on the pattern of progression of failure. Failures, as expected, do progress more rapidly in Type I tests than Type IV tests. It is also possible that fluid failure patterns would change if Type IV tests were conducted with fluids other than Ultra+. In order to fully determine the differences in Type IV fluid performance and behaviour, further full-scale testing using the different Type IV fluids would be required.

4.1.1.9 Effect Of the Quantity of Type IV Fluid Applied

The relationship between the quantity of Type IV fluid applied to a wing and the pattern of progression of wing failure is examined in this section. The tests chosen for this comparison were ID # 18 and ID # 19. Both tests were conducted on Fokker 100 aircraft in the same tailwind condition, and Type IV fluid was used on both wings. The amount of fluid applied to each wing, however, was different. On the starboard wing (ID # 18), 55 litres of Type IV fluid were applied, while on the port wing (ID # 19), 115 litres of Type IV were used (see Figure 4.3). No other set of tests was conducted in 1996/97 in similar tailwind or headwind conditions, using different amounts of Type IV fluid.

Holdover time results from Tests ID # 18 and ID # 19 show some differences. Three conditions were evaluated for the two tests; 10% wing failure; 25% wing failure; and condition of wing after 60 minutes. 10% wing failure occurred after 42 minutes in ID # 18 (rate 14.8 g/dm²/hr), and 31 minutes in ID # 19 (rate 22.4 g/dm²/hr). Since the rates of precipitation were significantly different, a calculation of the snow accumulation up to the 10% failure time in each test was computed. The results show that 12% more snow fell during the 31 minutes to 10% wing failure in ID # 19, than in the 42 minutes to 10% wing failure in ID # 18. The wing 25% failure times of 52 minutes (ID # 18) and 51 minutes (ID # 19) were similar. The rate of precipitation, however, was substantially higher in ID # 19. A comparison of the failure contour drawings for each test revealed that 65% of the total wing area had

failed after 60 minutes in ID # 18, compared to only 35% in 60 minutes in ID # 19. The rate of precipitation for the 60-minute period was also higher in ID # 19.

Fluid thickness measurements were taken at three different predetermined locations on the wing surface at different times during the tests. Results from these measurements show that film thickness levels were higher in ID # 19.

The comparison of results from ID # 18 and 19 show that the quantity of Type IV fluid applied to a wing appears to effect the pattern of progression of failure.

Since this statement is based on the outcome of only one set of related tests, more testing would be required to conclusively determine what the effects are.

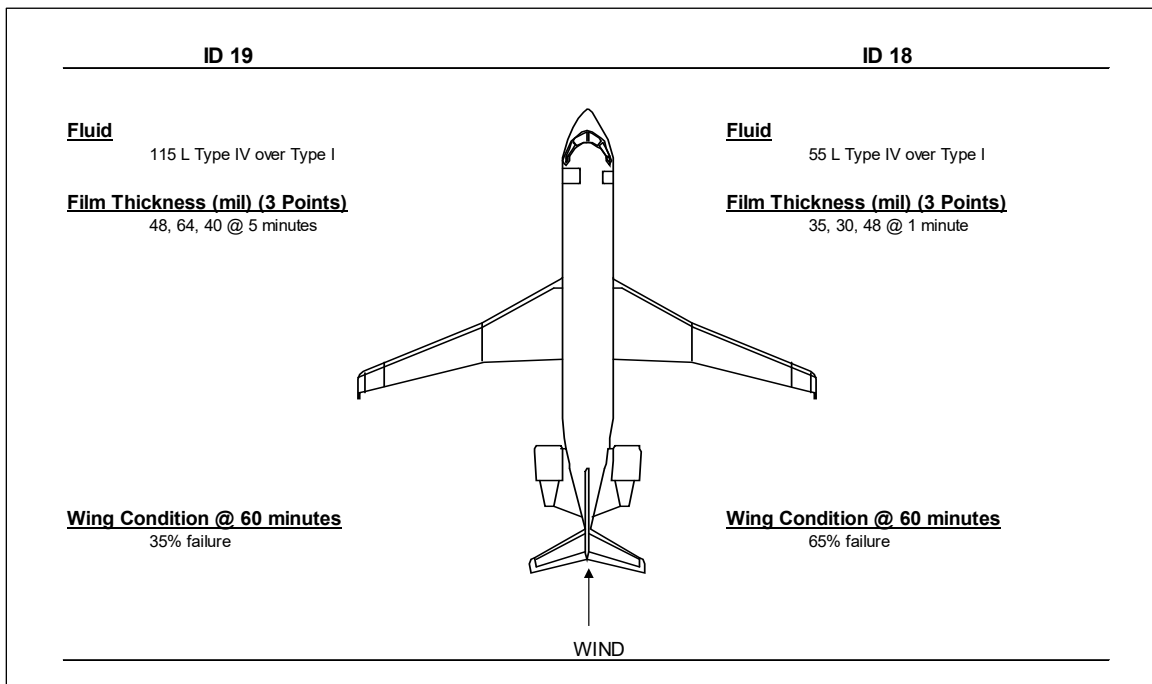


Figure 4.3: Observed Rate of Wing Failure for Different Fluid Quantities

4.1.1.10 Effect of Engines On/Off on The Progression of Failure

Three ATR 42 turboprop tests were conducted in 1996/97. The durations of the tests were short, due in large part to very high rates of precipitation. As a result, the test results were inconclusive, because proper observation of the progressions of failure was impossible. The effects of propeller wash on the progression of failure of the ATR 42 wing were not determined, since wing failures occurred prior to the initial inspection of the wing, following engine shutdown.

4.1.2 Validity of the Representative Surface

The representative surfaces on aircraft wings are intended to assist flight crews in the identification of fluid failures. In this section, the validity of the representative surfaces on the aircraft used in full-scale testing is discussed.

The current methodology used to delimit the representative surface is useful. Thickness tests conducted in 1995/96 (see TP 12900E) on slatted winged aircraft showed that the leading edge experienced the lowest values of fluid film thickness in all tests conducted with Type IV fluid. No other area of the wing experienced equivalent reduction of fluid thickness, which led to the conclusion that any area selected to serve as representative must include the leading edge.

The next most critical areas with respect to fluid thickness are the flaps, ailerons and spoilers of the trailing edge. There is merit in their inclusion as a component of the representative surface, as these surfaces may be more visible to an observer from inside the cabin. Also, since it has been shown that hard-winged aircraft experience the majority of failure on the trailing edge, reference to the trailing edge is also significant.

Boeing 737

The representative surface on the Boeing 737 tested is located on the inner wing, inboard of the engine, and spans the leading edge and mid-wing (see Photos 5.17 and 5.18 of Appendix F; and Figure 2.5). The section of the representative surface on the leading edge does not show a high occurrence of early failures, due to the hard wing design of the Boeing 737, inboard of the engine (as shown in Figure 3.18 and Figure 3.22). In fact, when first failure on the wing was declared, only 12% of tests showed failures on this section of the representative surface. When 10% of the wing had failed, failures were present on this section of the representative surface in only 30% of tests.

The representative surface on the mid-wing section exhibited little or no early failures. The representative surface on the Boeing 737 as tested does not include the trailing edge, although the trailing edge shows moderately high occurrence of early failures. At wing first failure, 19% of tests conducted on the Boeing 737 have failures present on the trailing edge, below the current representative surface (see Figure 3.18). When 10% of the wing has failed, the occurrence of failure on the trailing edge, below the representative surface, increases substantially to 69% of all tests (see Figure 3.22).

The selection of the most appropriate representative area for aircrew reference should reflect those surface areas that would be expected to fail earliest. Based on the occurrence of failure charts in Figure 3.18 and Figure 3.22, the most suitable location for the representative surface on the Boeing 737 would be just outboard of

the engine pylon, and would span the entire chord of the wing. At this location, the leading edge exhibited failures in nearly 40% of tests at wing first failure time. When 10% of the wing had failed, the occurrence of failure on the leading edge at this location was 100%.

Fokker 100

The representative surface of the Fokker 100 wing is located on the outer wing section, outboard of the second flap fairing, and spans the mid and trailing edge sections of the wing (see Figure 2.5).

Due to the hard wing design of the Fokker 100, the trailing edge is the most failure-sensitive area of the wing. The trailing edge section of the representative surface has a 100% occurrence of early failures (see Figure 3.17 and Figure 3.21).

Based on the high occurrence of failures, the current location of the Fokker 100 representative surface is valid. It should be noted that the representative surface is located far from the fuselage, and failure detection in adverse conditions could be difficult. It is expected that this will be resolved in the 1997/98 test season.

McDonnell Douglas DC-9

The representative surface on the McDonnell Douglas DC-9 at the time that tests were performed in 1995/96 was located on the inner mid-section of the wing, and did not extend to the leading and trailing edges. Results of tests conducted in previous years showed that the representative surface for this aircraft type was not a conclusive representation and that, in the majority of cases, wing first and 10% failures occurred elsewhere (see Figure 3.19 and Figure 3.23).

When 10% of the McDonnell Douglas DC-9 wing had failed, the highest occurrence of failure was located on the leading edge outer section, followed by the aileron on the trailing edge (Figure 3.23). The outer leading edge position, due to the consistent presence of early failures, would be ideal for representative surface placement. Further testing would be required to determine if significantly improved visibility of the representative surface from the cabin would be achieved if the representative surface was positioned in closer proximity to the fuselage. Resolution of this uncertainty is expected to be forthcoming in the 1997/98 test season.

4.1.3 Sensor Placement

In this section, possible sensor locations on the leading edge, trailing edge and mid-wing sections for the various aircraft types used in the course of full-scale testing are examined. In addition, an evaluation has been carried with respect to the positioning of the sensors at locations delineated by the representative surface.

All the observations in this section, which pertain to point detection sensor placement, are based on the use of early fluid failure locations as a criterium for determining ideal point detection sensor locations. Other criteria might dictate more suitable locations for sensor placement.

4.1.3.1 Leading edge

Boeing 737, leading edge

The following observations pertain to sensor positioning on the leading edge of Boeing 737 aircraft:

- First failures occur primarily on the aileron and on the leading edge mid-section (see Figure 3.18);
- Leading edge failure was invariably present when 10% of the Boeing 737 wing had failed. At this time, the mid-wing leading edge exhibited failure in every test, and the outer wing leading edge showed failure in the majority of tests (see Figure 3.22). Failures were imminent in the unfailed outer wing leading edge sections at the time of 10% failure. The inner wing leading edge shows much lower occurrences of failure, due to the hard wing design of the Boeing 737, inboard of the engine; and
- Wing sample data, collected at points on the leading edge in the minutes following the time when 10% of the wing had failed, were compared to samples taken elsewhere on the wing at the same time. For example, sample data collected on the mid-wing mid section in the minutes following 10% wing failure had fluid freeze points well below ambient temperatures. This indicates that the fluid at this location was still providing a protective film layer to the wing. Samples collected at two leading edge locations had fluid freeze points near ambient temperatures, suggesting that failures were present or imminent. Freeze points on the mid-wing leading edge were closer to ambient temperatures than on the outer wing leading edge, which indicates that failures had progressed further on the mid-wing section of the leading edge.

The results show that the leading edge mid-section would be the most suitable leading edge location for sensor placement on Boeing 737 aircraft, due to its consistent occurrence of failures at the time of 10% wing failure. The least suitable section of the leading edge for sensor placement would be the inner section.

Fokker 100, leading edge

The following observations pertain to sensor positioning on the leading edge of Fokker 100 aircraft:

- Because of the hard wing design of the Fokker 100, failures initiate primarily from the trailing edge;
- Only 2 of 13 tests conducted on Fokker 100 aircraft exhibited failures on more than 10% of the leading edge at the time when 10% of the entire wing had failed (see Figure 3.24). It should be noted that both were Type IV tests with only slightly more than 10% leading edge failure;
- Wing first failure occurred primarily on the trailing edge sections (see Figure 3.17). Some leading edge failure is present at the wing joints;
- Figure 3.21 shows that 10% failures occurred largely on the trailing edge, however leading edge failures are not uncommon. In certain wing grid locations on the leading edge, failures occurred in 38% of all tests. Leading edge failure in Fokker 100 tests normally starts at the wing joints and progresses outward; and
- Wing sample data from leading and trailing edge sample locations were compared. Samples from the leading edge mid-section, taken within minutes of 10% wing failure, had freeze points below those of samples taken at the trailing edge at the same time.

The results show that the trailing edge area would be the most suitable area for sensor placement for detection of first failure of fluids. Consideration of aerodynamic effects of contamination may favour a leading edge placement for sensors. This latter consideration is outside the scope of this report.

McDonnell Douglas DC-9, leading edge

The following observations pertain to sensor positioning on the leading edge of McDonnell Douglas DC-9 aircraft:

- First failures occur primarily on the leading and trailing edges (see Figure 3.19). Failures at this point are spread quite evenly over the whole surface of the leading edge, with the highest occurrence of failure on the leading edge outer section;
- The highest occurrence of failures for the McDonnell Douglas DC-9 wing (see Figure 3.23) at 10% wing failure appear on the leading edge outer section (grids # 47 and # 50). Failures were present in 10 of 11 tests at these locations. In the remaining test, failures at these locations occurred just slightly after the 10% failure of the wing; and
- Since all the McDonnell Douglas DC-9 tests were conducted in 1995/96, no sample data were collected for this aircraft type.

The results of McDonnell Douglas DC-9 tests show that the leading edge outer sections, near the wing tip, would be the most strategic locations for sensor placement.

4.1.3.2 *Trailing Edge*

Boeing 737, trailing edge

The following observations pertain to sensor positioning on the trailing edge of Boeing 737 aircraft:

- The highest occurrence of first failure on the trailing edge occurs on the aileron (see Figure 3.18);
- Figure 3.22 shows high occurrences of 10% wing failures on the aileron of the trailing edge outer section, and on the spoiler panel on the trailing edge inner section; and
- Unfortunately, no samples were collected on either the aileron or spoiler panels for Boeing 737 tests. As a result, no comparison of fluid freeze points was possible for samples collected on these surfaces versus the other wing sections.

Results from the Boeing 737 tests show that the aileron would be the best location for sensor placement on the trailing edge, if a sensor could not be placed on the leading edge. Failures were present on the aileron in 13 of the 16 tests at wing 10% failure time. In the remaining three tests, failures occurred soon after 10% wing failure. Another possible location for placement would be the spoiler on the inner section of the trailing edge, since 10% wing failures occur on this section in 11 of the 16 tests. Once again, in tests that did not show failure at this point, failures occurred soon after.

Fokker 100, trailing edge

The following observations pertain to sensor positioning on the trailing edge of Fokker 100 aircraft:

- First wing failures, and failures when 10% of the entire wing had failed, were almost exclusively located on the trailing edge for the Fokker 100;
- Wing first failures, shown in Figure 3.17, were present in all tests on the aileron. There is also a high occurrence of first failures on the spoilers and flaps for the Fokker 100;
- At the time that failure had progressed to the 10% level, failures were present in all tests on the spoilers, flaps and ailerons of the trailing edge (see Figure 3.21). The wing tip also showed a high occurrence of failures at wing 10% failure time; and
- Fluid samples collected on the aileron, when the wing failure had reached the 10% level, were compared to samples taken on the mid-wing leading edge.

Samples from the aileron, collected within four minutes of 10% wing failure, had freeze points closer to ambient temperatures than those of samples taken on the leading edge. This suggests that when 10% of the Fokker 100 wing has failed, the progression of failures on the aileron were further advanced than on the leading edge.

The information for the Fokker 100 shows that the trailing edge is a far more suitable area on which to place sensors, due to the high occurrences of failure on several different locations of the trailing edge.

McDonnell Douglas DC-9, trailing edge

The following observations were made pertaining to the positioning of sensors on the trailing edge of the McDonnell Douglas DC-9:

- At wing first failure, and when 10% of the wing had failed, the aileron on the trailing edge shows the highest occurrence of failure. This is shown in Figure 3.19 and Figure 3.23;
- The flap and spoiler sections on the trailing edge mid-section and outer section also show high occurrence of failures when the wing has failed to the 10% level; and
- No samples were collected for these tests.

Results of the McDonnell Douglas DC-9 tests show that the most suitable area for sensor placement on the McDonnell Douglas DC-9 trailing edge is the aileron. If trailing edge sensor placement is not possible on the aileron, then the flap and spoiler sections of the trailing edge mid and outer sections are good alternatives.

4.1.3.3 Mid-wing Sections

Mid-wing sections are normally last to fail for all aircraft types used in full-scale testing, and occurrences of first wing failure on these sections was rare. Occurrences of initial failures on the mid-sections were usually simultaneous with initial failures of either leading or trailing edge sections. At 10% wing failure levels, the presence of contamination on the mid-section of the wing was somewhat higher than in the initial failure case, but still far less than contamination levels of the leading and trailing edge sections. For this reason, it is recommended that sensors be placed on either leading or trailing edges (depending on the aircraft type) and not the mid-section.

The statement above is further supported by fluid sampling. Fluid samples from the mid-wing section were compared to samples from the leading edge for Boeing 737 aircraft. The freeze points of samples taken on the mid-wing section within

four minutes of 10% wing failure were below ambient temperatures. The freeze points of samples taken at two leading edge locations within four minutes of 10% wing failure were at, or near, ambient temperatures, suggesting that failures had occurred, or were imminent, at the leading edge sample locations.

Aircraft leading and trailing edges are the most appropriate locations for sensor placement, due to the high occurrences of early failures on these surfaces. The positioning of sensors on the mid-wing section, capable of providing reliable information on contamination located elsewhere on the wing, would be more complex than if the sensor was positioned on the leading or trailing edges.

As such, an algorithm relating to failures on the leading and trailing edges would need to be developed and validated if sensors are to be positioned on the mid-wing. As well, a contamination sensor with sensor head raised above the surrounding wing surface could be developed to artificially stimulate fluid thinning, and thereby emulate fluid conditions actually observed on the leading and trailing edges.

4.1.3.4 Representative Surface

The occurrences of failure on the representative surfaces of the Boeing 737, Fokker 100 and McDonnell Douglas DC-9 are discussed in this section, in relation to the positioning of sensors on these surfaces.

Boeing 737, representative surface

The representative surface on the Boeing 737 wing on the aircraft tested were located on the leading and middle inner sections of the wing (see Figure 2.5). The section of the representative surface on the leading edge does not show a high occurrence of early failures, due to the hard wing design of the Boeing 737 leading edge, inboard of the engine. The representative surface on the mid-wing section showed little or no early failures (see Figure 3.18 and Figure 3.22).

No fluid samples were taken on the representative surface of the Boeing 737, and as such no freeze point comparison with other wing sections was possible.

The representative surface of the Boeing 737 is not the most ideal location for sensor placement, due to the low occurrences of failure. If sensors were placed on this surface, an algorithm would need to be developed in order to predict the state of failure on the wing, based on the condition of the wing on the representative surface.

Fokker 100, representative surface

The representative surface of the Fokker 100 is located on the outer sections of the wing (see Figure 2.5). The sections of the representative surface on the leading edge and wing mid-section showed little in the way of failures. The section of the surface on the trailing edge showed high occurrences of failure.

Samples were collected during the course of full-scale tests on the leading and trailing edges of the representative surface. Samples taken on the trailing edge had higher freeze points in the minutes following 10% wing failure than those taken at locations on the leading edge. This confirms that the trailing edge in the representative surface sees more failure than the leading and mid-sections.

McDonnell Douglas DC-9, representative surface

The representative surface on the McDonnell Douglas DC-9 is located on the inner mid-section of the wing. Results of tests from previous years showed that the representative surface for this aircraft type was not appropriate. In the majority of cases first and 10% failures occurred elsewhere on the wing. No sample data exists for this aircraft type.

Due to the fact that failures, for the most part, are occurring at locations on the wing other than the representative surface, an algorithm would have to be developed to predict the condition of the rest of the wing if sensors were to be positioned on this area.

4.1.3.5 Overall Sensor Placement Summary

The most suitable locations for sensor placement, using a criteria of first location of fluid failure, would be those wing sections where failure occurrences are highest and most consistent. Figure 4.21 (included at the end of this section) shows the preferred locations for sensor placement for Boeing 737, Fokker 100 and McDonnell Douglas DC-9 aircraft. Wing sections were ranked from # 1 to # 7, with # 1 being the best location for sensor placement # 2 being the second best location for sensor placement, and so on.

4.1.4 Holdover Time Correspondence

This section of the report examines the relationship between the failure times for Type I and Type IV fluids on aircraft wings, versus failure times on flat plates. Flat plate tests were conducted simultaneously with aircraft tests during the course of full-scale testing. Plates V and Y were used for Type I fluid, and flat plates W and Z for Type IV fluid. Deicing/Anti-icing fluids used in full-scale tests were Union Carbide Type I (XL54) and Union Carbide Type IV (Ultra +).

4.1.4.1 Comparison of Flat Plates and Wing

Figure 4.4 and Figure 4.5 show aircraft failure times (time to first failure and failure times for 10% and 25% of the wing entire area) plotted, versus the average of the standard fluid plate (V and Y, W and X) failure times. A one-to-one line is also shown on each chart. Best-fit lines, using linear regression methods, were performed with the data points for each aircraft for Type I tests, and appear on the charts. Regression lines were also drawn for Type IV fluid, using only data points from test ID # 17, 19, 24 and 35. Due to the problem of inadequate Type IV fluid application, several Type IV tests (ID # 18, 29, 34) were omitted in the regression analysis. Fluid for these tests was applied using the wand method, which is now widely viewed by the industry as a poor method of application for Type IV fluids. The Type IV fluid application trials conducted at Mirabel Airport on April 9, 1997 (as discussed in Subsection 4.2.2 of this report) were a direct result of this type of poor fluid application, and provide guidance on improved fluid application methods.

Another test (ID # 13) was omitted from the regression analysis due to a reduction in the rate of precipitation following plate failure. Two McDonnell Douglas DC-9 tests conducted in 1995/96, using Ultra Type IV fluid, were combined with the remaining Type IV tests from 1996/97 in order to produce the Type IV fluid regression analyses.

The top chart in Figure 4.4 shows that Type I flat plate failure times were greater than aircraft first failure times. Wing first failure occurs before, or at, plate failure in 84% of the cases. Plate failure time was about 38% longer on average than wing first failure. Best-fit linear regression lines of the Boeing 737 and Fokker 100 data points fall well below the one-to-one line.

The middle chart in Figure 4.4 shows a good correlation between average flat plate failure times and 10% wing failure times for Type I tests, with data points evenly dispersed around the one-to-one line. The wing 10% failure occurs before, or at, plate failure time in exactly 50% of the cases. Plate failure time was about 1% longer on average than wing failure time. Linear regressions for both aircraft reveal a near one-to-one correlation.

The bottom chart in Figure 4.4 shows that average flat plate failure times were inferior to aircraft 25% failure times for Type I tests. The majority of the data points are above the one-to-one line. In fact, wing 25% failure occurs only 22% of the time prior to plate failure. Plate failure time was about 20% shorter than wing failure time. Regression lines for both Boeing 737 and Fokker 100 aircraft are above the one-to-one line.

The top chart in Figure 4.5 shows that flat plate failure times were greater than aircraft first failure times for tests conducted with acceptable Type IV fluid application. In fact, all the data points are below the one-to-one line. Plate failure time was, on average, 80% longer than wing first failure. The aircraft regression line is well below the one-to-one line at wing first failure.

The middle chart in Figure 4.5 shows that flat plate failure times were greater than aircraft 10% wing failure times for tests conducted with acceptable Type IV fluid application. The wing 10% failure occurs before plate failure in 57% of the tests. Plate failure time was, on average, 10% longer than wing 10% failure. The aircraft linear regression falls just below the one-to-one line, suggesting a good correlation.

The bottom chart in Figure 4.5 shows that flat plate failure times were shorter than aircraft 25% wing failure times for tests conducted with acceptable Type IV fluid application. The wing 25% failure occurs after plate failure in all tests. Plate failure time was, on average, 17% shorter than 25% wing failure. The aircraft regression line is above the one-to-one correlation line.

It can be observed from these charts that flat plate holdover times are equivalent to 10% wing failure times for Type I fluids. The charts for Type IV tests show that flat plate holdover times are similar to 15% wing failures, however very good fluid applications would probably reduce this number to 10%. It can thus be concluded that flat plates are good representations of 10% failed wings for Type I and Type IV fluids.

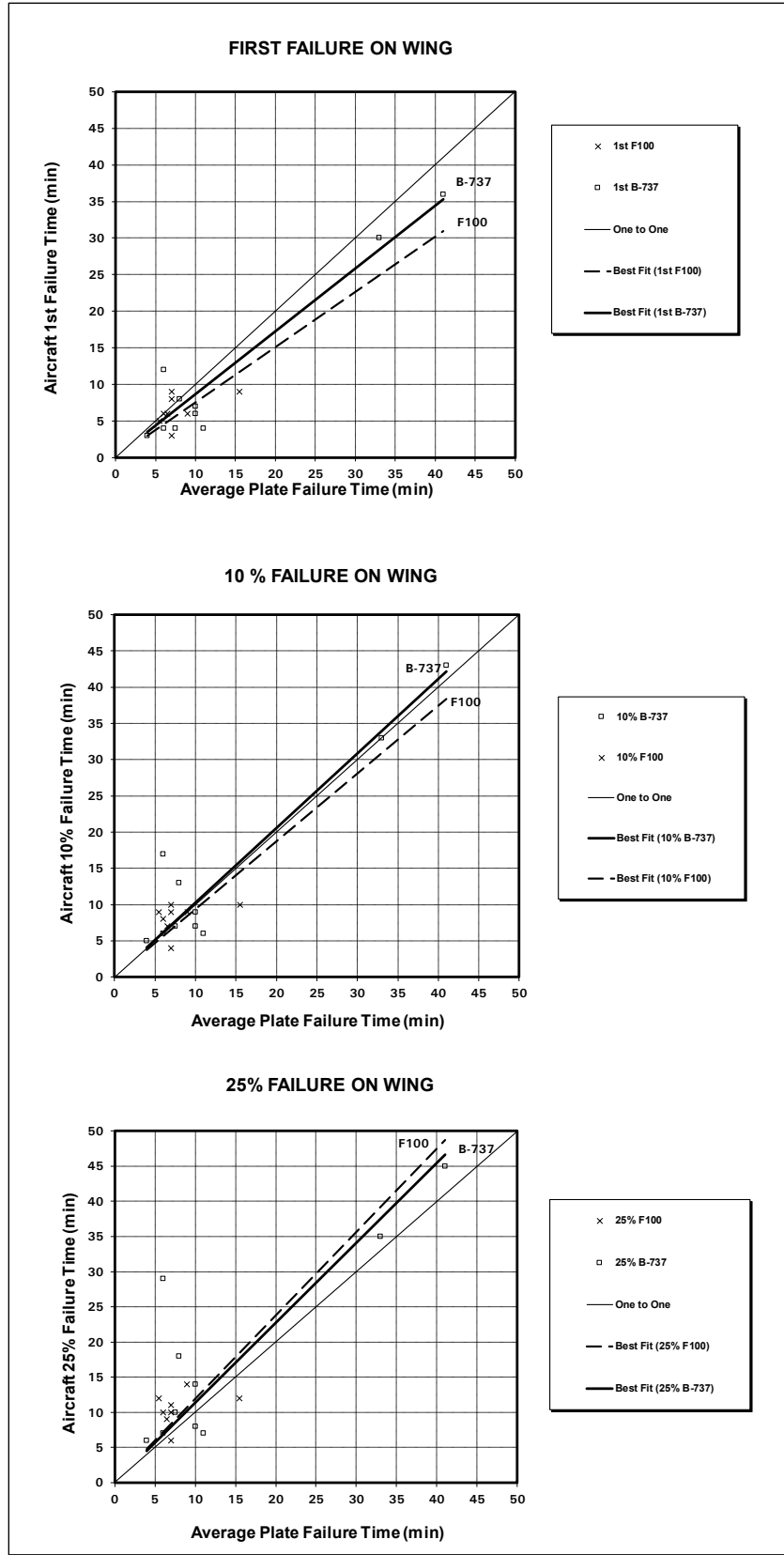


Figure 4.4: Comparison of Wing and Plate Failure Time for Type I Fluid

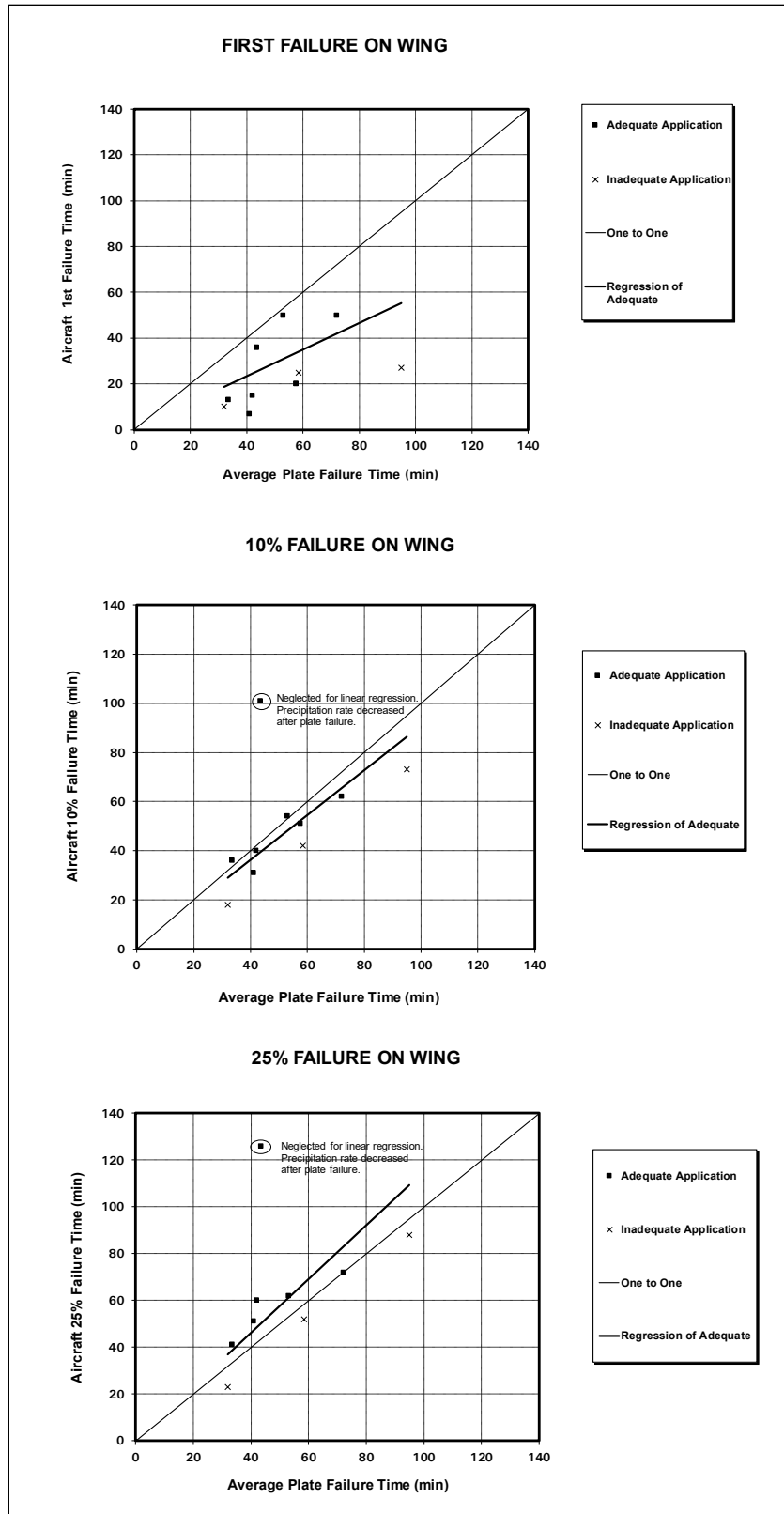


Figure 4.5: Comparison of Wing and Plate Failure Time for Type IV Fluid

4.1.4.2 Comparison of Wing Failure Times to SAE Holdover Times

Figure 4.6 and Figure 4.7 show aircraft failure times (time to first failure and failure times for 10% and 25% of the wing area) plotted, versus the Type I and Type IV fluid holdover time ranges for natural snow conditions, substantiated by flat plate testing. Since Ultra+ was the only Type IV fluid tested during the course of full-scale tests for 1996/97, both the fluid-specific and SAE Type IV holdover time ranges appear on the charts. The charts for Type I tests include only one holdover time range, since individual fluid holdover times do not exist for Type I.

Figure 4.6 shows Type I wing first failure, 10% failure and 25% failure data points plotted versus the 6 to 15 minutes holdover time range for Type I fluid in natural snow conditions. Four full-scale Type I tests experienced first wing failure prior to the holdover time lower limit of 6 minutes. At wing 10% failure, only one data point was below the lower limit. In this case (ID # 32) the wing was in a downwind position, and reached 10% failure in four minutes due to the obvious increase in the rate of precipitation. All the 25% wing failure data points are within, or above, the holdover time range for Type I fluid.

Two full-scale tests were conducted in 1996/97 with Type I fluid in light freezing rain conditions. Charts were not made for these tests, due to a lack of data points. All the points for wing first failure, 10% and 25% failure are above the Type I light freezing rain holdover time range of 2 to 5 minutes.

Figure 4.7 shows Type IV wing first failure, 10% failure and 25% failure data points plotted versus the different SAE holdover time ranges for Type IV fluid in natural snow conditions. The holdover time ranges for Ultra+ have also been included at the top of the charts. Several wing first failure points are below the SAE and fluid-specific holdover time ranges, and most of these result from poor Type IV fluid applications. At 10% and 25% wing failure, three points fall below the lower holdover time limit for Ultra+, however the rate of precipitation for two of the tests was greater than the 10 to 25 g/dm²/hr range used to substantiate Type IV holdover times in natural snow conditions. For the third test, the 10% wing failure time was 31 minutes, which is 4 minutes less than the SAE and Ultra+ lower holdover time limit. The rate of precipitation for this test was 22 g/dm²/hr.

One test was conducted using Type IV fluid in light freezing rain conditions. The wing first failure time of 12 minutes is below the SAE and fluid-specific holdover time ranges. Times for 10% and 25% wing failure fall within the holdover time ranges.

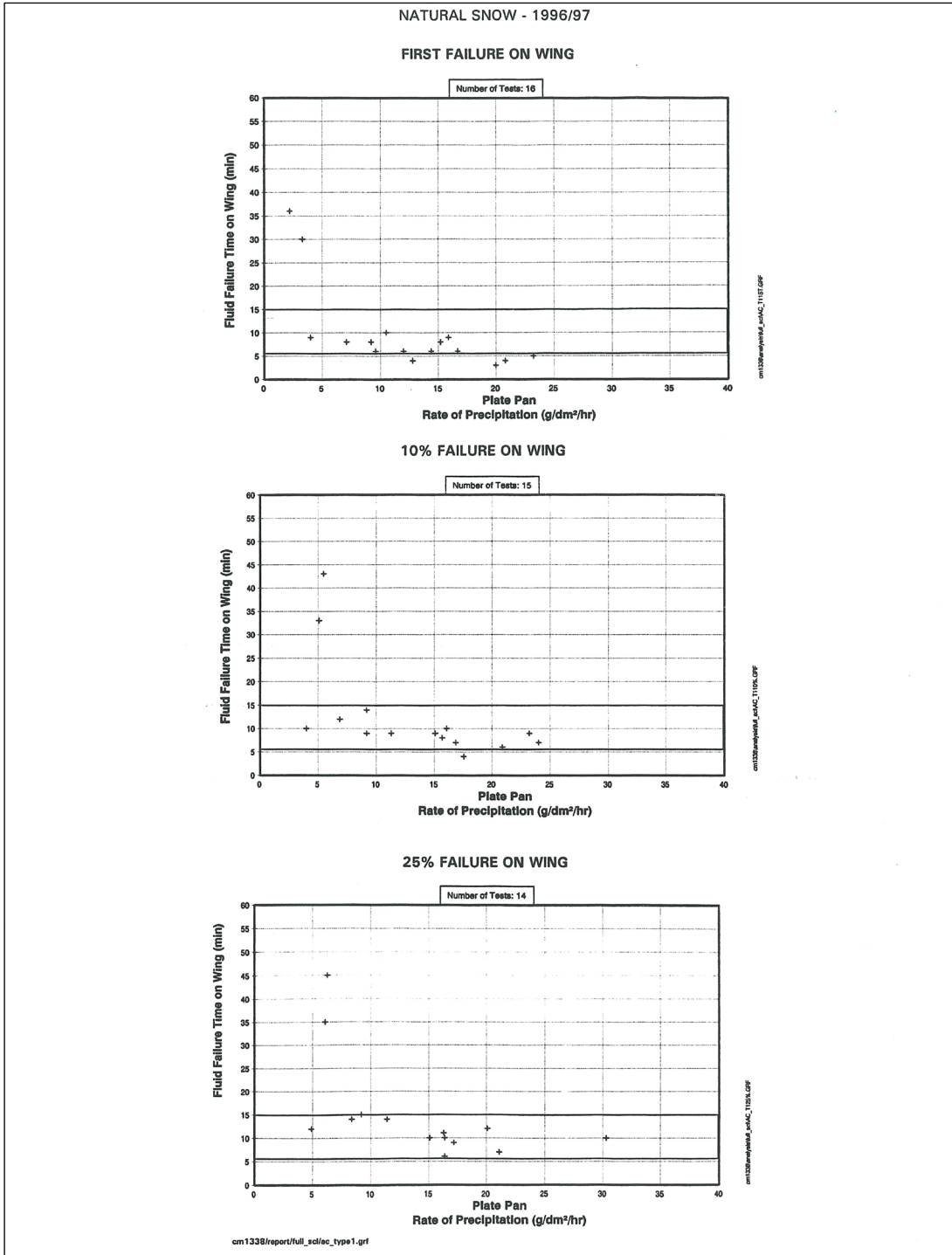


Figure 4.6: Effect of Rate of Precipitation on Failure Time – Standard Type I

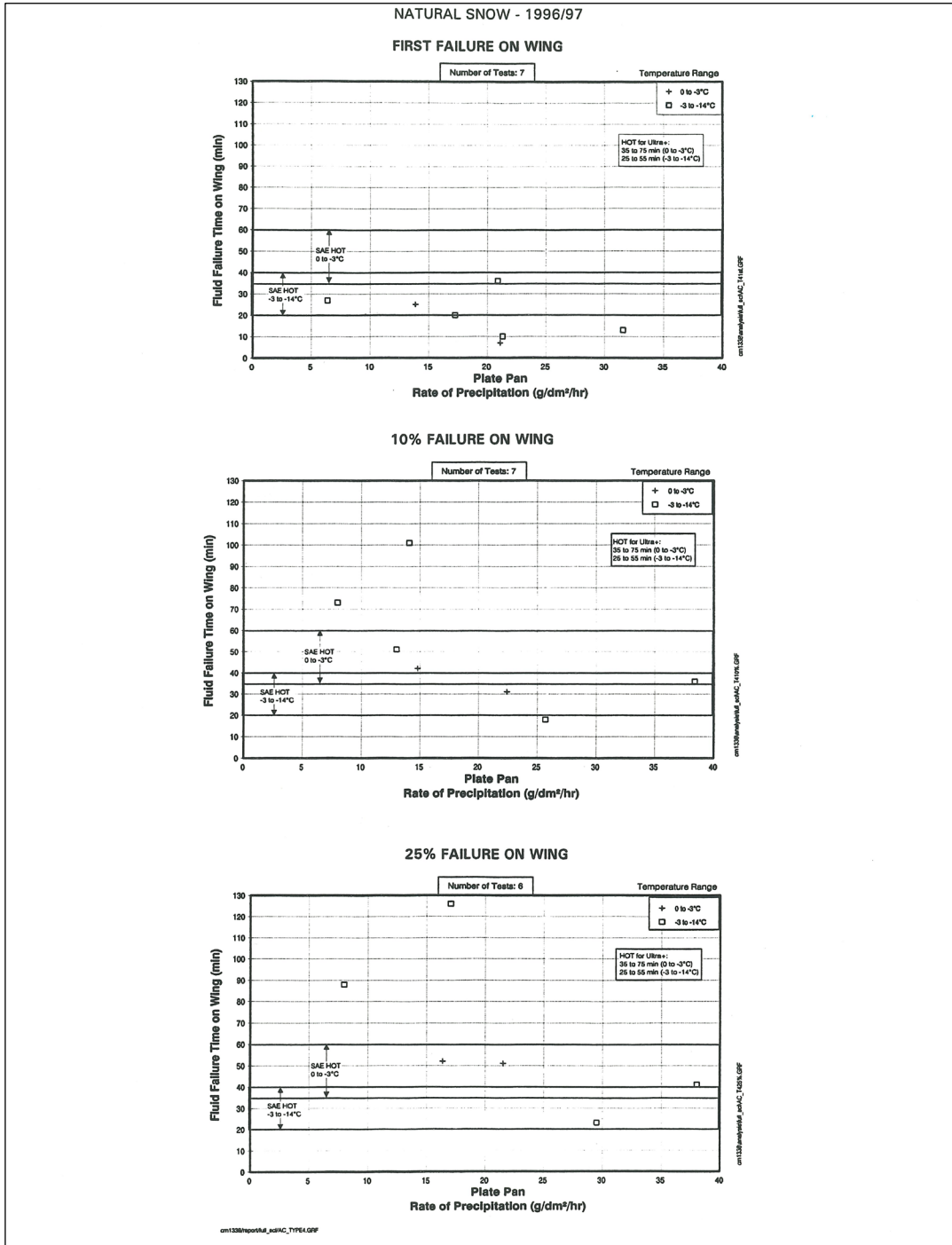


Figure 4.7: Effect of Temperature and Rate of Precipitation on Failure Time – Ultra + Type IV Neat

4.1.4.3 Correspondence of Flat Plate Holdover Times to SAE Holdover Times

A review of flat plate holdover times from full-scale fluid failure trials revealed that all Ultra+ Type IV data points were within the SAE worst case and fluid-specific holdover time ranges. Two XL54 Type I data points (ID # 14, Plate 2 and ID # 20, Plate 1) failed one minute prior to the lower limit holdover time for Type I fluids. The plate failure times are shown in Table 3.1.

4.1.4.4 Condition Of the Wing at the Occurrence of Plate Failure

Full-scale wing failure contours were examined to determine what percentage of wing failure corresponds to plate failure for different fluid types. Boeing 727 tests conducted by United Airlines in 1992/93 were used for this analysis, along with APS Aviation's 1995/96 and 1996/97 tests on McDonnell Douglas DC-9, Boeing 737 and Fokker 100 aircraft. At plate failure time for each test, the percentage of wing failure was calculated using the individual contour drawings. The results were separated by aircraft and fluid type, and are shown in Figure 4.8 to Figure 4.10.

Figure 4.8 shows that in half the Type I tests, the percentage of wing failure at plate failure time was between 6 and 10%. With the exception of two tests conducted in ice pellet conditions where the wings had completely failed prior to plate failure, the average wing failure for the remaining 24 Type I tests was 9.5%. Figure 4.9 shows that the majority of Type II tests showed less than 10% wing failure at plate failure. The average percentage of wing failure was 12% for the eight tests. Failure percentages for Type IV tests in Figure 4.10 show that all tests with good Type IV fluid application had less than 15% wing failure at plate failure time. The average percentage of wing failure at plate failure time was 11% for these tests.

The percentage of wing failure versus plate failure charts confirm the results obtained from previous comparisons: flat plates are good representations of 10% failed wings for Type I and Type IV fluids.

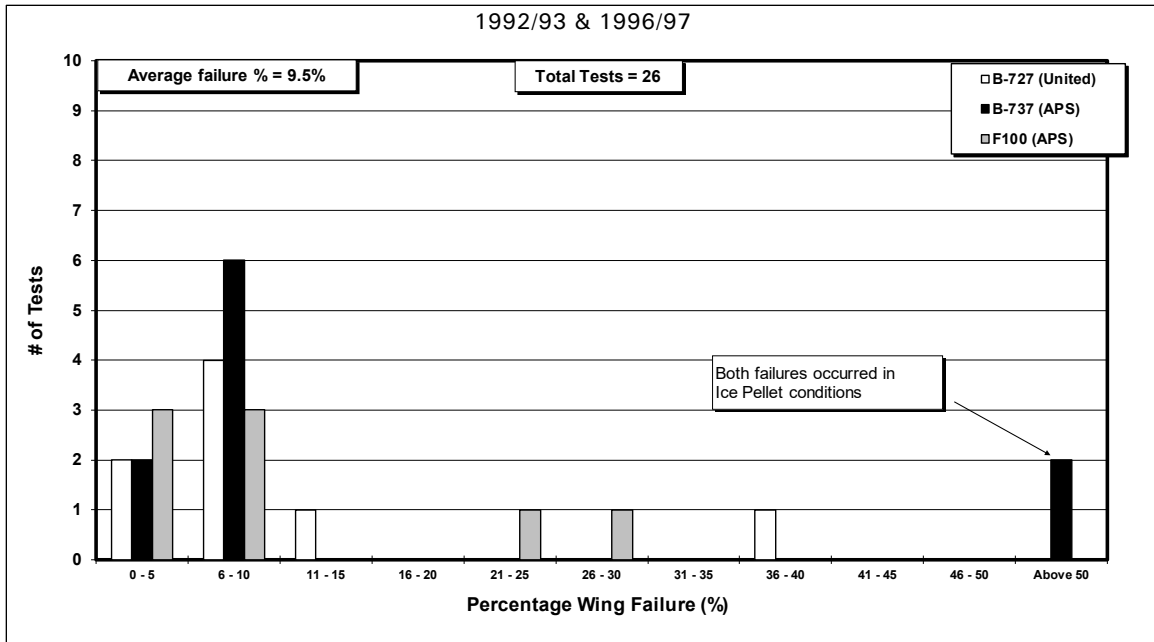


Figure 4.8: Condition of the Wing at Occurrence of Plate Failure, Type I Fluid

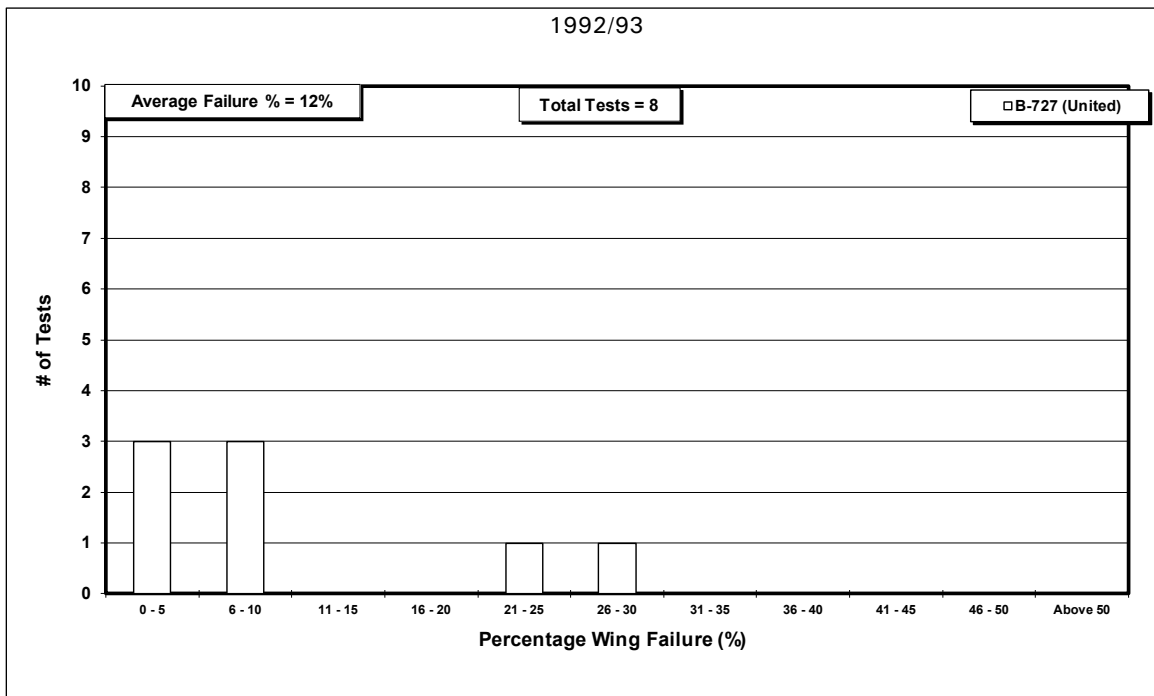


Figure 4.9: Condition of the Wing at Occurrence of Plate Failure, Type II Fluid

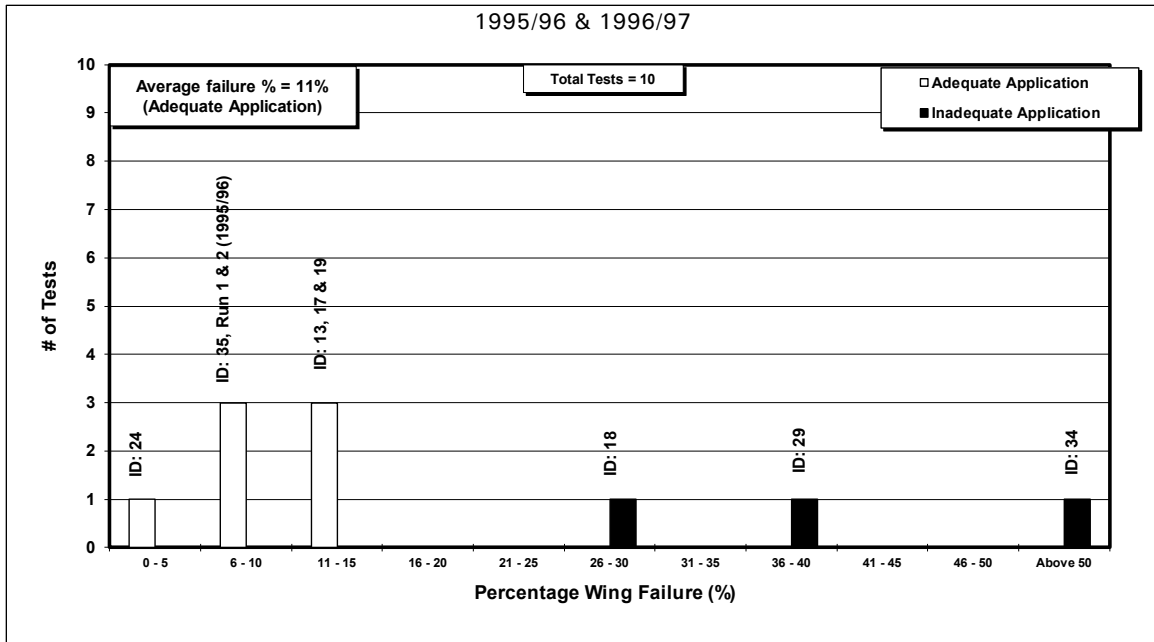


Figure 4.10: Condition of the Wing at Occurrence of Plate Failure, Type IV Fluid

4.1.4.5 Comparison of Flat Plates with Wing Ailerons and Spoilers (Fokker 100)

Full-scale tests on Fokker 100 aircraft were studied in order to determine the relationship between flat plate failure times and wing aileron and spoiler failure times. Failure drawings of the 13 Type I and Type IV Fokker 100 tests conducted were examined to determine failure times for the different wing sections. Aileron and spoiler failures were called when 50% of the individual areas had failed. One-to-one charts for Type I and Type IV fluids were prepared for comparison to flat plates, and appear in Figure 4.11.

Figure 4.11 shows strong correlations between flat plate failure times and spoiler and aileron failure times. Data points are almost evenly distributed above and below the one-to-one line for both fluid types. Although they do not show on the charts, a linear regression analysis was performed with the aileron and spoiler data points and, in every case, the regression lines fell just below the one-to-one correlation lines.

The results show that flat plates are good representations of Fokker 100 ailerons and spoilers, particularly for Type IV fluids. Therefore, it can be expected that holdover time ranges, substantiated by flat plate testing, would be similar for these surfaces.

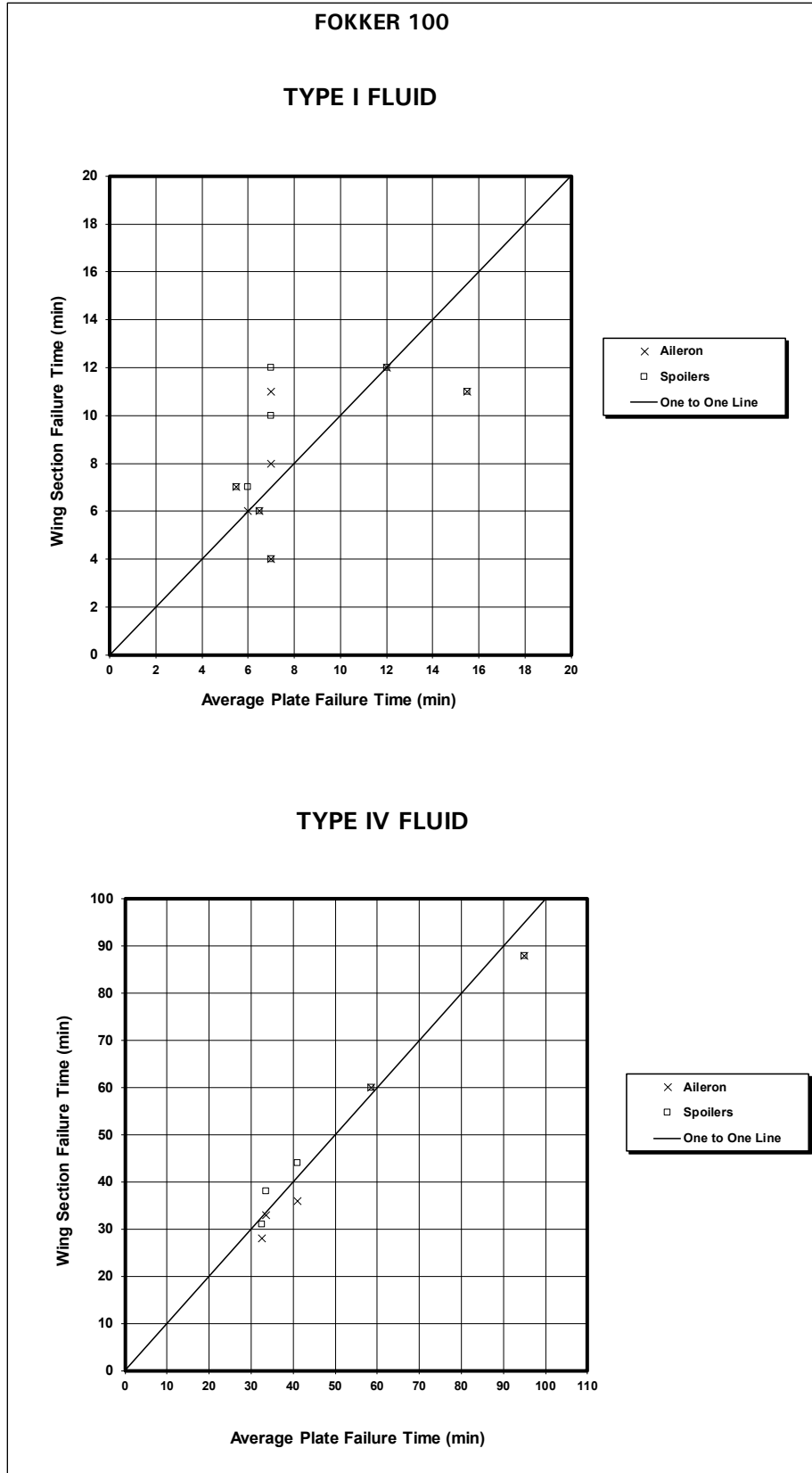


Figure 4.11: Aircraft Aileron and Spoiler Failure vs Average Plate Failure

4.1.5 Appearance of Fluid Failure

This section discusses the appearance of fluid failures on various aircraft wings, in different conditions. During the course of standard flat plate testing, it was observed that the appearance of failed fluid varied with the fluid type, precipitation type, rate of precipitation and temperature. The photographs, videotapes and failure contour drawings from 1995/96 full-scale tests on McDonnell Douglas DC-9 aircraft, and 1996/97 full-scale tests on Fokker 100 and Boeing 737 aircraft, were reviewed in order to determine if similar differences in failure appearance exist on aircraft wings.

4.1.5.1 Freezing Drizzle and Light Freezing Rain

During the course of flat plate testing, it was observed that freezing drizzle and light freezing rain failures were not always easily identifiable. In some cases, visual inspection alone was not sufficient for detecting failures. An object, such as a pencil, was used to determine the presence of ice adhering to the individual cross hairs on the flat plate. The same is true for tests on aircraft wings.

Full-scale tests in light freezing rain conditions were conducted in 1995/96, and in 1996/97. Figure 4.12 describes the test conditions for the 1995/96 trials on McDonnell Douglas DC-9 aircraft. The test temperature on this occasion was constant at -1°C . Artificial lighting was used in order to view the failures, and was positioned in ideal locations around the wing surfaces. Photos and video coverage of the fluid behaviour were taken during the tests.

The top photograph in Photo 4.1 shows the condition of the fluid on the wing prior to failure. The green dye of the Ultra fluid provided confirmation at the start of the test that fluid was present. The bottom photograph was taken on the opposite wing, which was not protected with fluid. Ice on the wing surface occurred soon after the freezing rain started. The detection of ice in this photo is difficult, due to a lack of contrast between any two areas on the wing surface. Although the wing has failed, this lack of contrast could lead to the false belief that there is fluid on the wing, when viewing the surface from a distance.

Photo 4.2 clearly shows Type IV fluid failure on the wing leading edge. In the top photograph, the fluid failures were simple to identify because the failed area was matted, in contrast to the adjoining shiny part of the leading edge. Similarly, the contrast between the fluid on the mid-wing sections and the failed leading edge provided easy failure identification. The bottom of Photo 4.2 shows a close-up view of the failure on the McDonnell Douglas DC-9 leading edge.

Figure 4.13 illustrates the general test conditions for the 1996/97 light freezing rain tests. Freezing rain tests were conducted on one occasion using a Boeing 737 aircraft. The ambient temperature for the first test on this occasion was -3.5°C

(2:00 AM), and increased steadily throughout the course of the test period. The final test, which started at 3:48 AM, was conducted at 0.5°C.

In Photo 4.3, the Type IV failures on the leading and trailing edges are clearly visible. The ambient temperature for this test was -3°C. Tactile tests also revealed the presence of ice adhering to the wing at this time (25% wing failure). The leading edge failures in the top photographs in Photo 4.2 (McDonnell Douglas DC-9 test) and Photo 4.3 (Boeing 737 test) show notable similarities. A Type I test, conducted following the Type IV test at the same temperature, also revealed similar failures.

The Type I leading edge failure in the top of Photo 4.4 does not resemble previously shown failures. The ambient temperature for this test had increased to -1.5°C. The difference in failure appearance may be related to the warmer test temperature, the Type I fluid used versus the Type IV in the previous photographs, or an increase in the rate of precipitation since the last Type I test. In the bottom photograph, 80% of the wing surface has failed.

The location shown in the photograph has also failed, although the failure is not apparent. Tactile tests revealed that ice was indeed adhering to the wing at this location, and water spots were also found to be resting on top of the ice. The American quarter in this photo was used as a scale to measure contamination size.

In Photo 4.5, the Type I fluid on the wing sections in both pictures appears to have failed. Tactile tests, however, revealed only liquid. Although no failures were present in the trailing edge photograph in Photo 4.5, some spots closely resemble the failed trailing edge in Photo 4.3. The same is true for the close-up in Photo 4.5, which bears a striking resemblance to the close-up in Photo 4.4, but once again ice was not present, due to the ambient temperature for the final test, which had just risen above 0° C.

It can be concluded from these photographs that the appearance of failure in freezing drizzle and light freezing rain can be deceiving. The ambient temperature appears to have a direct effect on the appearance of failure in these conditions. The difficulties in determining failures in these conditions stresses the importance for the advancement of research related to the operational use of wing sensors and ice detection cameras.

APS Aviation has photo and video records available on CD-ROM of all full-scale tests conducted, and these records could be used for training purposes.

Since Ultra+ was the only Type IV fluid used this year during the course of full-scale testing, it should be noted that different results were seen during flat plate tests with Type IV fluids from other manufacturers. Union Carbide Ultra+ and Hoechst Type IV fluids thinned and froze to the plate at failure at most temperatures. At -10°C, Octagon and Kilfrost Type IV fluids failed when a sheet of ice formed on top of the

fluid. Flat plate tests using Type I fluid in freezing drizzle or rain ended with ice adhering to the plates. This ice had to be removed with a scraper following each test.

Date:	February 28, 1996
Aircraft Type:	McDonnell Douglas DC-9 Series 30
Airline:	Air Canada
Fluid Type:	Type IV Ultra over Type I XL54
Precipitation Type:	Light Freezing Rain
Precipitation Rate:	Approximately 15 g/dm²/hr
Wind Speed:	15 kph
Aircraft Orientation:	Nose into wind
OAT:	-1°C (constant)

Figure 4.12: General Conditions For 1996 Light Freezing Rain Tests

Date:	February 21, 1997
Aircraft Type:	Boeing 737
Airline:	Canadian Airlines
Fluid Type:	Type IV Ultra+ over Type I XL54 or Type I XL54
Precipitation Type:	Light Freezing Rain
Precipitation Rate:	Approximately 20 g/dm²/hr
Wind Speed:	8 kph
Aircraft Orientation:	Nose into wind
OAT:	2:00AM = -3.5°C 3:00AM = -2.5°C 3:30AM = -1.5°C 3:45AM = 0°C 4:00AM = 0.5°C

Figure 4.13: General Conditions For 1997 Light Freezing Rain Tests

4.1.5.2 Natural Snow

Natural snow tests conducted on flat plates showed that failures occurred when the fluid had thinned, and snow started to accumulate on the plate. Failures also occurred due to snow bridging, which occurs especially in high rate conditions when snow starts to rest on top of the fluid (the fluid can no longer absorb the snow at the rate it is falling). Certain Type IV fluids, such as Kilfrost and Octagon, see high occurrences of snow bridging-type failures in all rates of precipitation. In all natural snow cases, regardless of the method of fluid failure, an accumulation of snow was apparent in the failed areas.

Snow failures on aircraft wings are shown in Photo 4.6. The top picture shows a Type I failure, two minutes following failure at the leading edge location. Because the fluid has thinned, the surface of the wing is quite dry of fluid, and snow crystals have accumulated on the wing. The bottom picture on the page shows a Type IV failure, one minute following failure at the mid-wing location. In the Type IV failure, snow crystals have started to accumulate, although it appears to be much more slushy than the Type I failure. This is common for Type IV failures in natural snow conditions.

Snow bridging failures are shown in Photo 4.7. Since no full-scale tests were conducted with Type IV fluids other than Ultra + , pictures of other fluids were taken from flat plate tests at Dorval Airport. The fluid used in this test was Kilfrost Type IV Neat. The rate of precipitation for this test was 15 g/dm²/hr. It can be seen that white snowflakes are resting on the green fluid and are no longer being absorbed. The plate was called failed at the 15 cm (6") line just prior to these photographs, even though there still seems to be a substantial amount of fluid on the plate under the snow.

Type I and Type IV natural snow failures normally did not adhere to the flat plate surfaces, and could easily be removed with a squeegee following plate failure. If natural snow failures were allowed to remain on the plates for extended periods of time following failure, they would solidify, and their removal would involve some scraping.

It should be noted that all full-scale and flat plate tests were performed using artificial illumination (floodlights, spotlights) placed at ideal locations. Without this lighting, which is probably the case in most operational conditions, failure detection would have been substantially more difficult.

Preliminary tests from a previous report were aimed at comparing the failure calls of observers located inside and outside the aircraft cabin. Although the tests were conducted in the most ideal conditions, results still showed that the inside observer could not distinguish fluid failures as easily as the outside observer. Since it was

shown earlier in this section that the appearance of failures can be deceiving, even to the outside observer in certain conditions, it can be assumed that the inside observer would even have a more difficult time determining failures based on the appearance of the fluid from inside the cabin. In order to properly compare the failure calls and fluid appearance observations of inside and outside observers in operational conditions, more full-scale testing would be required.

4.1.6 Depiction of Fluid Roughness

At the request of the Transportation Development Centre of Transport Canada, APS Aviation endeavoured to depict the roughness of a failing Type I deicing fluid. The overall objective was to determine the aerodynamic effects of contaminated Type I fluid on the lift generated by a Fokker 100 aircraft wing.

Eight full-scale tests were conducted by APS Aviation during the 1996/97 test season, using Fokker 100 aircraft sprayed with Type I deicing fluid. The tests were performed on two different nights, under natural snow conditions. Rates of precipitation were measured with plate pans, and ranged from 4 to 23 g/dm²/hr. The temperature varied from -1°C to -4°C, and wind speeds were between 7 and 20 kph. Tests were conducted in tailwind, headwind and crosswind conditions, and fluid failure contours were drawn by wing observers for each test. Videotape and photo records of fluid and failure patterns were also recorded.

In order to produce a model of Type I fluid failure progression for a Fokker 100 wing, the failure contours for each of the eight tests were examined. Video and photo records were used for support. The contours revealed similar patterns of failure up to the point where 20% of the total wing area was contaminated. Photo 4.8 shows views of the trailing edge failure pattern. With the exception of some scattered leading edge failure at the wing joints, the bulk of the contamination at the 20% wing failure point was located on the flight control surfaces of the trailing edge. First wing failure occurred on the top areas of the spoiler panels and ailerons. Failures on the bottom areas of the same surfaces ensued, followed by the flap sections closest to the fuselage, the leading edge wing joints, the central flap sections, and the outer portions of the ailerons.

Using the failure progression pattern, the degree of fluid contamination within each of the failed sections was determined. Test photographs of the different wing sections were enlarged, to expose the density and height of contamination peaks within each square inch of the failed areas at the 10% and 20% wing failure times (see Photo 4.9). Failure density was obtained by drawing a one square inch box on the enlarged photograph, and then counting all the contamination peaks within.

Peak heights were determined in comparison to the size of the American quarter (1.5 mm). The failure progression contours, along with the various degrees of contamination within each of the sections, are shown in Figure 4.14.

The fluid roughness data were sent to the National Research Council in Ottawa, where simulated aerodynamic analyses were performed. Computer simulations were conducted, using APS Aviation's figures, to determine at which point contamination density and size affect the lift generated by the wing. Results from these tests will be published by the National Research Council.

Aerodynamic lift is most strongly influenced by leading edge failure. Since the majority of the failures present on the Fokker 100 fluid roughness model are located on the trailing edge, it would be useful to produce similar models for aircraft on which fluid failure patterns occur primarily on the leading edge, such as the Boeing 737 or the McDonnell Douglas DC-9. Models could also be produced at different wing failure conditions (first wing failure, 10%, 25 %, 50%), and for different fluid types.

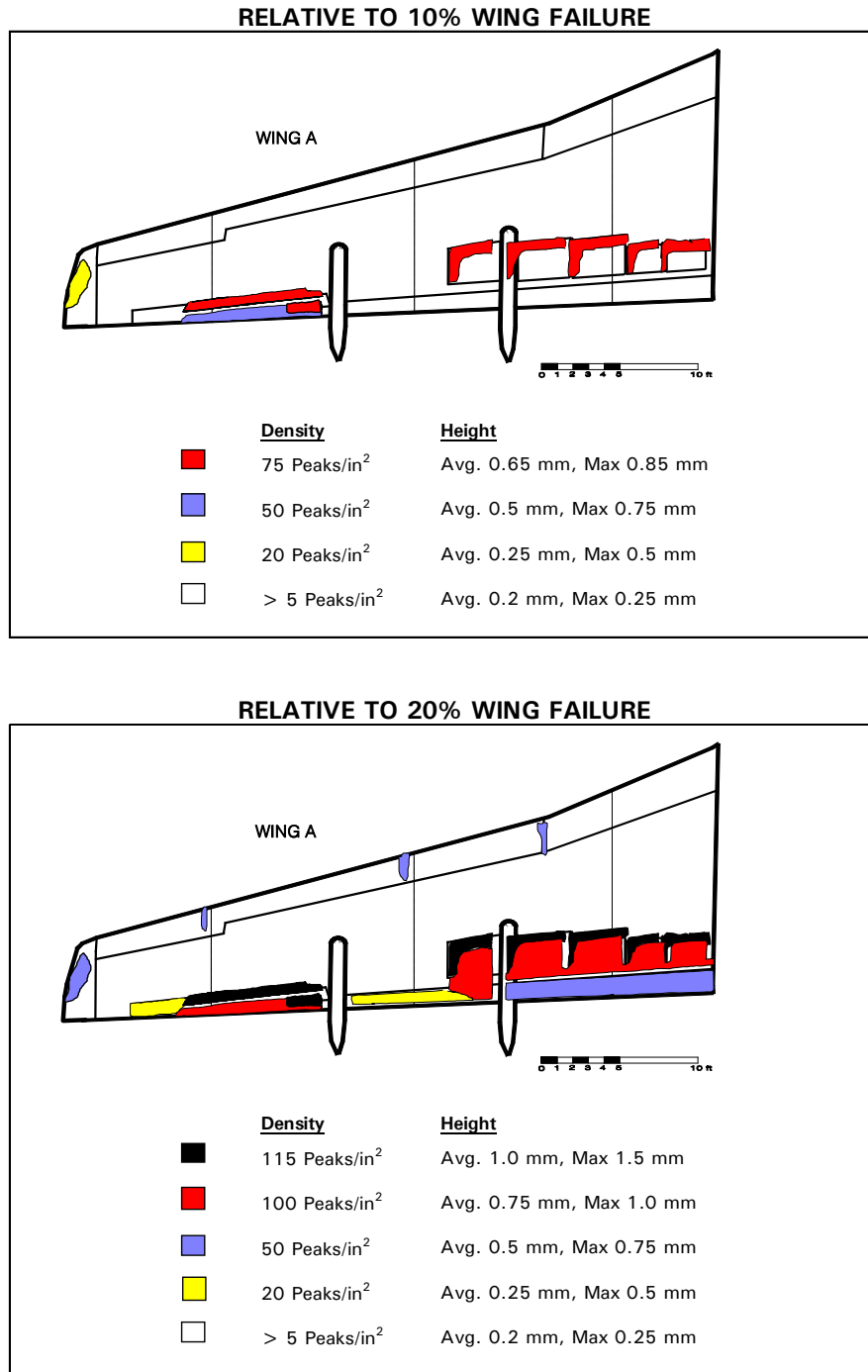


Figure 4.14: Depiction of Type I Fluid Roughness on Fokker 100

4.1.7 Documentation of Wing Area Visible to Flight Crew

Industry regulations for deicing require the flight crew to perform pretakeoff visual inspections under specific circumstances. Visual inspection of flight surfaces from the inside of an aircraft has some natural limitations associated with it, which for some aircraft includes a restricted view of the wing surface. The purpose of this activity was to document, through a series of photographs, the area of the wing that is visible to the flight crew.

Airlines at Montreal International Airport (Dorval) cooperated to allow access to a number of aircraft during ground time, while the cabin was free of passengers.

Photos were taken to illustrate the extent of the visible portion of the wing as it appeared from a number of windows. From the flight deck, photos were taken from the side window, both in the open and closed position. In the passenger cabin, photos were taken from windows located at the wing leading edge, trailing edge and at the over-wing exit.

For high wing aircraft, photos of the wing upper surface were taken from the open passenger door at the rear.

During the photo sessions, the wings were observed with the naked eye, and with the assistance of field binoculars (7X magnification) in order to explore the value of an optical aid.

A record was maintained of the operator, aircraft type and fin number, date, and seat row number where photos were taken.

Photo documentation was developed for four aircraft types; Boeing 737, Airbus A320, ATR 42 and Fokker F28. The Boeing 737 was photographed on two occasions. One of those occasions was during a snow storm, when the aircraft returned to the gate following deicing, due to an unserviceability. That circumstance enabled photography of views of the wing with contaminated fluid, and illustrated the reduced visibility caused by snow and deicing fluid adhering to the cabin windows.

A catalogued series of photos was developed, and is presented in Appendix F.

4.2 Fluid Thickness

This section will provide a detailed analysis of observations that relate to the fluid thickness trials.

4.2.1 Fluid Thickness Measurements

This subsection will present and analyse procedures and results associated with the measurement of fluid thickness on different aircraft types.

4.2.1.1 Fluid Thickness on Jet Aircraft (Boeing 737)

Fluid thickness trials on jet aircraft were limited to the Boeing 737, and to a single operator. During trials conducted on January 16 and January 22, 1997, it was observed that the Type IV fluid was unusually pale and thin. Samples were submitted to the fluid manufacturer for analysis, and prior to further trials on January 25, Union Carbide advised that the fluid was Ultra (not Ultra+), and that it had undergone partial decomposition through repeated thermal cycling. The remaining Ultra fluid contained in the operator's reservoir was disposed of and replaced with new Ultra+ fluid, which was used for subsequent trials on January 25 and February 21, 1997.

The design of fluid tankage on the deicing vehicles used by this operator situates the Type IV tank beside the heated Type I tank, sharing a common metal wall, which results in heat transfer to the Type IV fluid. This situation is thought to be common in the industry. It results from the adaptation of deicing vehicles, which were originally designed for delivery of Type I fluids, to dispense Type IV fluid.

The significance of heating Type IV fluids was investigated separately by applying heated Type IV fluids onto flat plates. This investigation is fully documented in Transport Canada report, TP 13131E, *Aircraft Ground De/Anti-icing Fluid Holdover Time Field Testing Program for the 1996/97 Winter*.

Relevant results from that study are presented in Figure 4.15, which presents four charts showing film thickness values for four brands of Type IV fluid. In each chart, the fourth set of bars represents thickness values for unheated neat Type IV fluid applied over heated Type I fluid. The fifth set of bars represents thickness for heated neat Type IV fluid applied over an application of heated Type I fluid.

The impact of heating Type IV fluid is striking. Thickness values for some heated Type IV fluids approach those offered by Type I fluids. Heated fluid film thickness measurements showed reductions of up to 80% relative to those for unheated fluids.

Figure 4.16 provides fluid thickness profiles along the chord of the wing for all tests in this series. The illustrated values for fluid thickness on plates is an average of values measured over all trials in the series. Measures of fluid thickness during the earlier trials (ID # T3 and ID # T4) reflect the deteriorated quality of fluid, resulting in reduced fluid thicknesses.

Trial ID # T5 also shows low values for fluid thickness, despite the fact that fresh fluid was used. This was a result of unsatisfactory spray application, and the test was halted after a short period. It should be noted that a wide range in the quality of fluid application was observed during these and other trials on aircraft, leading to the decision to conduct separate fluid application trials.

Trial ID # T6 was conducted with fresh Ultra+ fluid, and with a satisfactory spray application.

Trial ID # T11 was also conducted with new Ultra+ fluid. Application of fluid in this trial was of excellent quality, and provided a very consistent layer of fluid over the entire wing surface.

The rates of fluid thinning for the final two trials (ID # T6 and ID # T11) were similar to those seen in the 1995/96 study and showed fluid thickness stabilization in about 15 minutes. The fluid profile over the wing chord behaved as expected, with thickest fluid (2 to 3 mm) located on the high point of the wing, where the slope is lowest. As the slope of the wing profile increases (toward the leading and trailing edges), the fluid thickness decreases. The minimum thickness (0.5 mm) was observed on the nose of the leading edge.

Figure 4.17 shows the fluid thickness profile for the ID # T11 Boeing 737 trial, along with profiles for McDonnell Douglas DC-9, Canadair Regional Jet and Airbus A320 aircraft reported in the 1995/96 study.

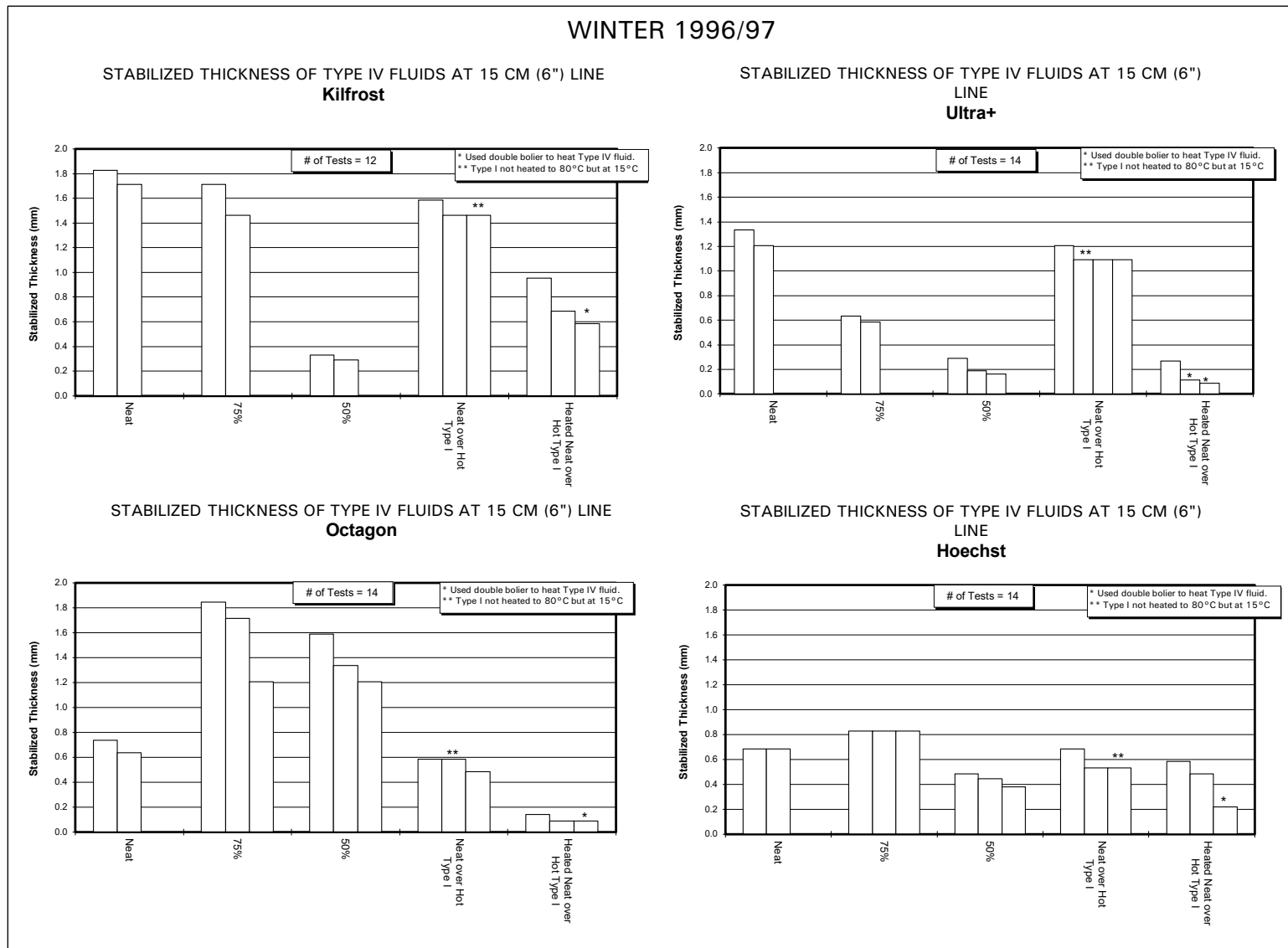
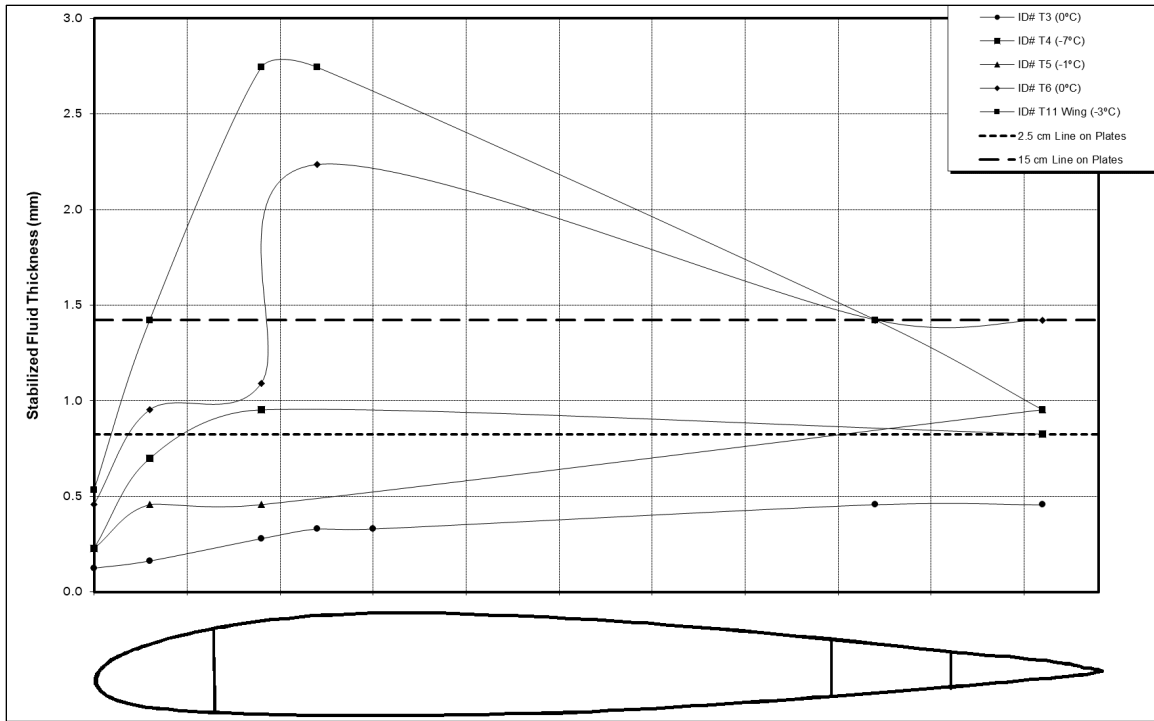


Figure 4.15: Film Thickness of Various Type IV Fluids



**Figure 4.16: Type IV Fluid Thickness (Stabilized) Profile – No Precipitation
Ultra + over XL54 on Boeing 737 Wing, Ultra + on Plates
Winter 1996/97**

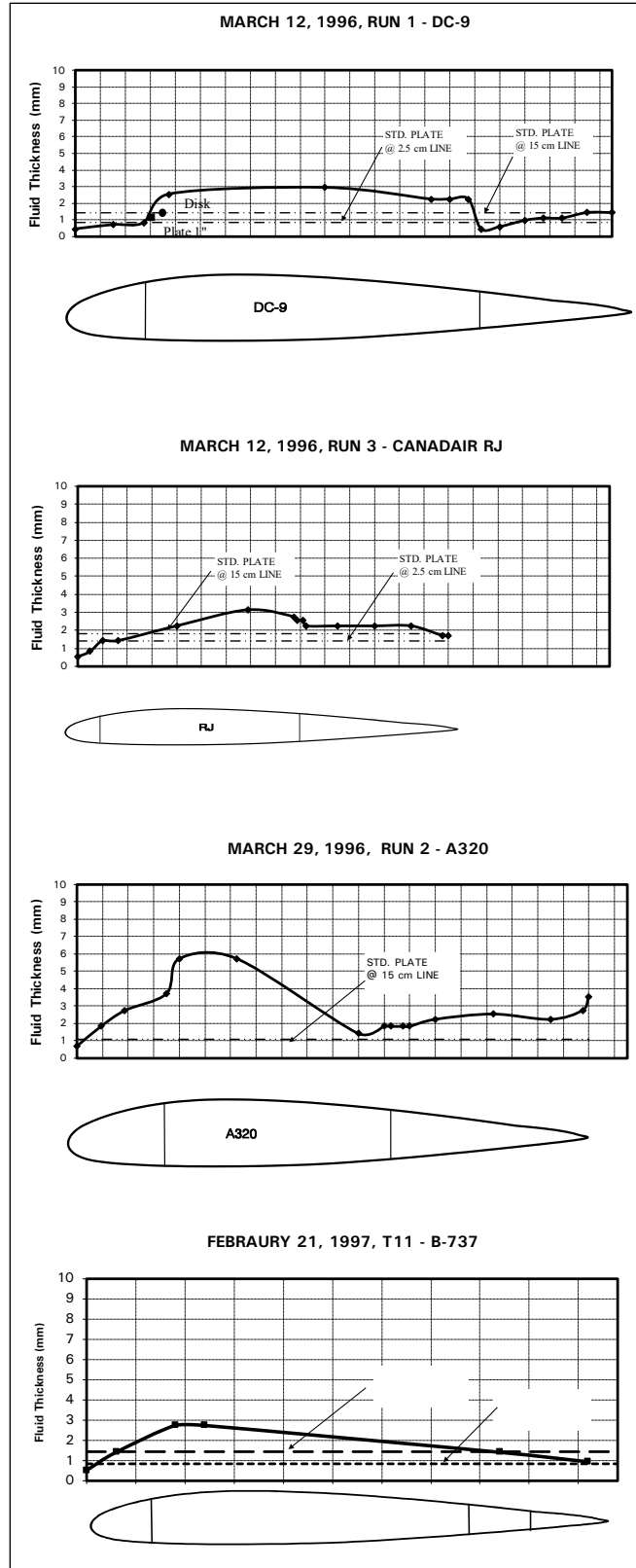


Figure 4.17: Type IV Fluid Thickness (Stabilized) Profile of a DC-9, RJ, Airbus A320, and Boeing 737

4.2.1.2 Fluid Thickness on Propeller Aircraft (ATR 42, DHC Dash 8)

Usable fluid thickness data were produced only from the trials on the ATR 42 aircraft.

For both Type I and Type IV fluid, the profile of fluid thickness along the top of the wing indicates that the propeller wash causes the fluid layer in the core of the propeller blown area (points 18, 19, and 20 in Figure 3.31) to become thinner. In the case of Type I fluid, the fluid layer appears to be blown laterally, forming a ridge of thicker fluid at the edge of the blown area, directly behind the propeller perimeter (points 14 and 15 in Figure 3.31). After running for five minutes, a very thin film of Type I fluid was still present just behind the propeller.

Type IV fluid in the core of the blown area (points 18, 19, and 20 in Figure 3.32) also demonstrated thinning. This fluid does not appear to pile up at the edge of the propeller wash area, as did the Type I fluid. Thickness measurements before and after propeller operation at points 15 and 17, just inside the blown area, are similar to values at points well outside the blown area (points 9, 12, 13, and 14 in Figure 3.32).

Photo 4.10 and Photo 4.11 provide a visual comparison of the layer of Type IV fluid on the wing, before and after operation of the propeller. The glossiness of the fluid, apparent in the before photo, has disappeared in the after photo, where the thinning of the fluid layer is quite apparent. Photo 4.12 provides an image of the wing at the boundary of the propeller wash area, and shows the thinning of fluid directly behind the propeller. This is further illustrated in Photo 4.13.

The profile of fluid thickness across the wing chord (Figure 4.18) is similar to fluid profiles on jet aircraft (Figure 4.16). This wing chord on the ATR 42 is well outside the area blown by propeller wash.

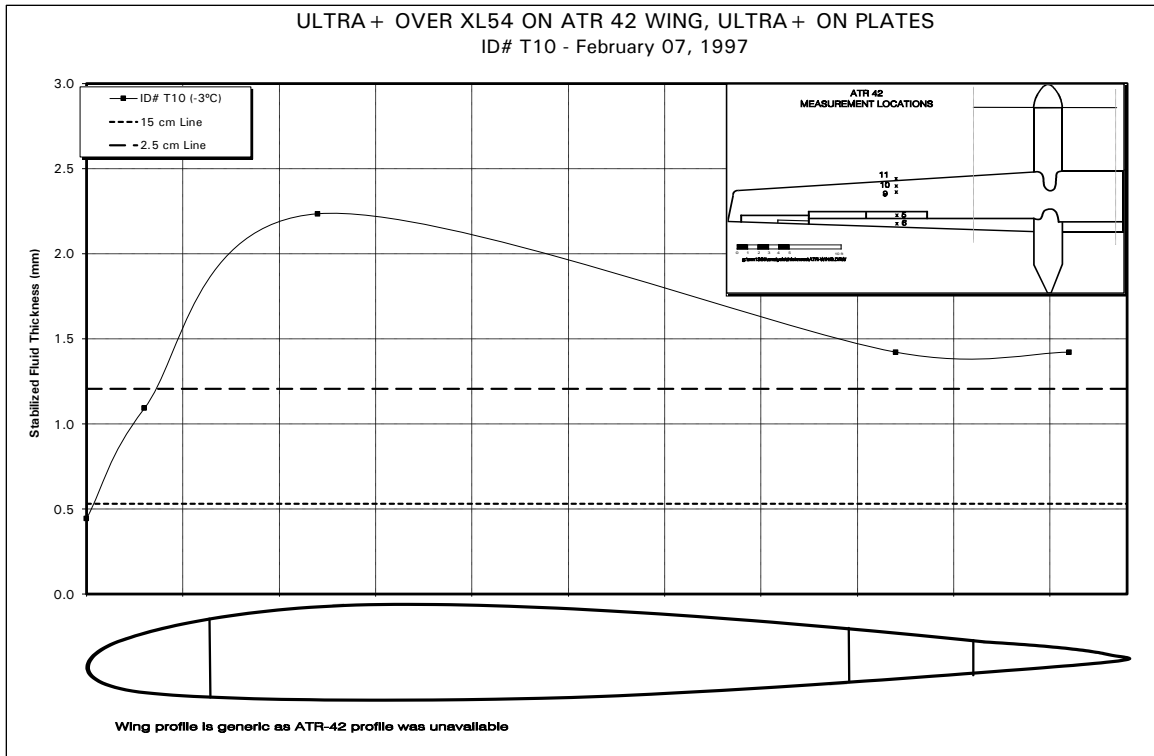


Figure 4.18: Type IV Fluid Thickness (Stabilized) Profile – No Precipitation

4.2.2 Fluid Application Techniques

This subsection will discuss and analyse procedures and results associated with the techniques of applying fluids.

4.2.2.1 General

Aircraft deicing trials conducted during this test season and during previous seasons, exhibited a marked variation in the quality of Type IV fluid application from test to test. This appeared to be influenced by the equipment in use (in particular, the fluid delivery nozzle), and by operator technique. Figure 4.19 presents fluid thickness profiles for Type IV fluids applied by three separate crews (all of whom are employees of the same operator), subjected to the same training program and procedures, and using the same equipment and fluid. The results differ significantly.

In an effort to assess the quality of fluid application during trials, fluid thickness was measured at six reference points distributed along the wing leading edge, during fluid failure trials on February 21 and March 6, 1997. Results of these measurements were deemed to be representative of the quality of the fluid application over the entire wing, and are shown in Figure 4.20. The thickness measurements at the six

locations from fluid failure trial ID # 27 are very consistent, and reflect earlier comments on the high quality of fluid application for thickness trial ID # T11, conducted by the same spray technician during this test session. A Task Force Tips nozzle was in use by this operator.

Fluid applications for fluid failure trials ID # 29, 34, and 35 were performed by a different operator, using a wand to apply Type IV fluid. The same spray technician performed spray operations for all three trials during a single test session. A notable variation in fluid thickness existed among the six reference locations in each trial, as well as between trials.

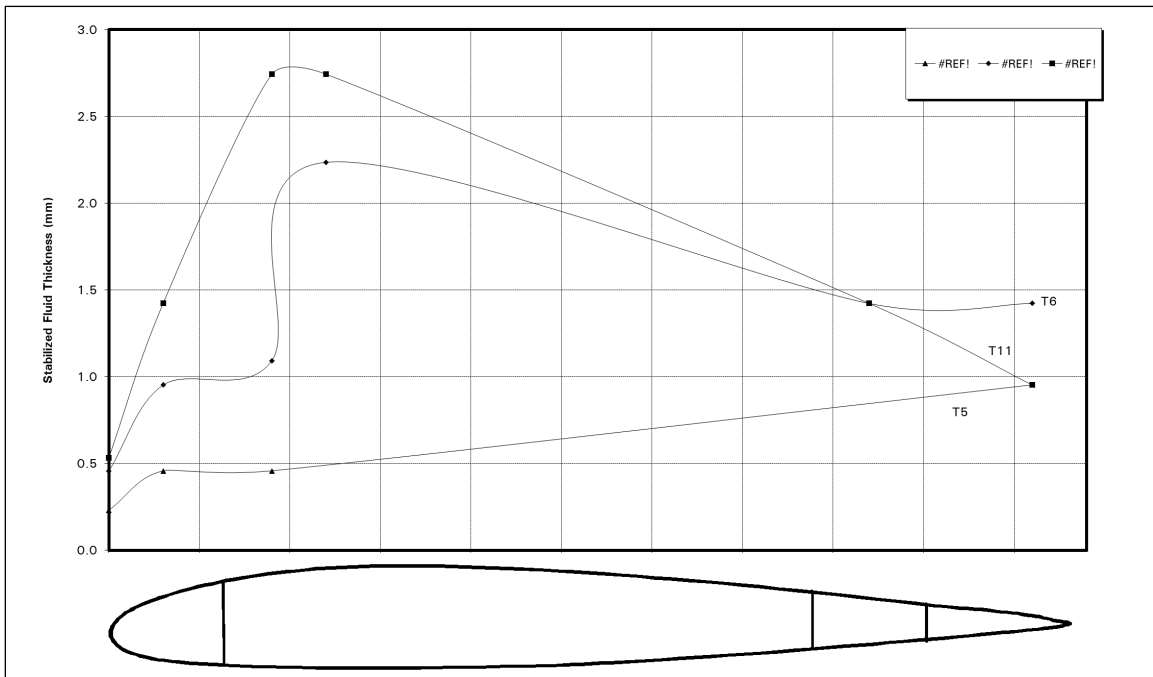


Figure 4.19: Thickness Profile for Three Crews

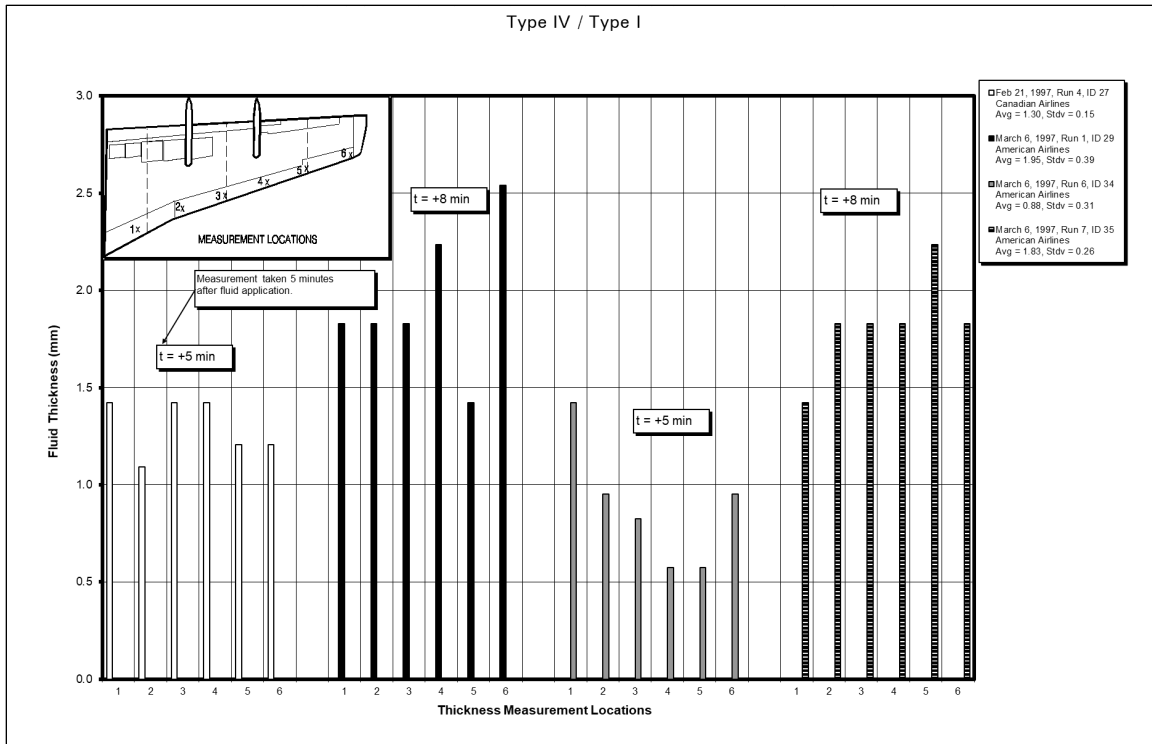


Figure 4.20: Consistency of Fluid Thickness on Leading Edge

4.2.2.2 Fluid Application Trials at Mirabel

This subsection details tests which were conducted on three different nozzle types at Mirabel Airport.

4.2.2.2.1 Test ID T18 Nepiro Nozzle – Standard Operation

The Nepiro nozzle used in this trial did not perform as well as expected. The operator described this nozzle as the standard, and most effective, hand-held nozzle for application of Type II and Type IV fluids, however the measured fluid thickness, and the consistency of the applied layer of fluid, was inferior to some later trials. As this was the first trial in the session, results may have been influenced to some extent by anxiety on the part of the person applying the fluids.

4.2.2.2.2 Test ID T19 Akron Nozzle – Standard Operation

The Akron nozzle is used by many operators for spraying Type I fluids. Some deicing trucks, which have been modified to pump Type IV fluid in addition to Type I, continue to be fitted with only one fluid line and nozzle. This nozzle was observed in

use for spraying Type IV fluids during trials in previous seasons, and generally resulted in a low-quality application, with ridging of fluid caused by fluid pressure.

In this trial, the nozzle was adjusted to provide a wide fan-shaped spray pattern, and the nozzle was positioned close to the wing surface. Special attention was given to leading edge coverage, with the spray fan overlapping the leading edge.

The resultant layer of fluid was quite consistent, without dark and light areas, and with film thickness meeting fluid manufacturers guidelines of 1 to 3 mm.

4.2.2.2.3 Test ID T20 Elephant β Standard Nozzle – Adjusted to A Narrow Stream

The operator reported that the Elephant β standard nozzle is normally used for hard-to-reach areas, such as the wing root or tail. In those applications, the spray nozzle is adjusted to a narrow stream.

In this trial, the narrow stream setting was used to spray nearby areas of the wing in order to simulate the observed practice of spraying with a concentrated, high flow stream.

This method of application caused the fluid spray to splash off the top of the wing, and resulted in very inconsistent coverage. Patches of thick fluid were interspersed with areas of very thin film, and thickness measurements were unreliable, due to the patchiness of the fluid layer.

4.2.2.2.4 Test ID T21 Elephant β Optional Nozzle – Standard Operation

The optional Type IV nozzle on the Elephant β is the standard nozzle used by this operator for applying Type IV fluid. Following standard operator's procedure, special attention was given to leading and trailing edges, with the spray fan overlapping the edge of the wing. The gentle spray delivered by this nozzle resulted in an even coverage of good thickness. The fluid volume sprayed was about $\frac{1}{2}$ the volume sprayed in the trial using the Akron nozzle.

4.2.2.2.5 Test ID T22 Elephant β Optional Nozzle – Continuous Spraying to Achieve Maximum Thickness of Fluid Film

In this trial, the operator was asked to continue spraying until the maximum possible thickness of fluid was reached. The resultant fluid layer was of exceptional consistency and good thickness. It is interesting to note that the thickness for this trial was exceeded by the best application observed during actual field trials (ID # T11).

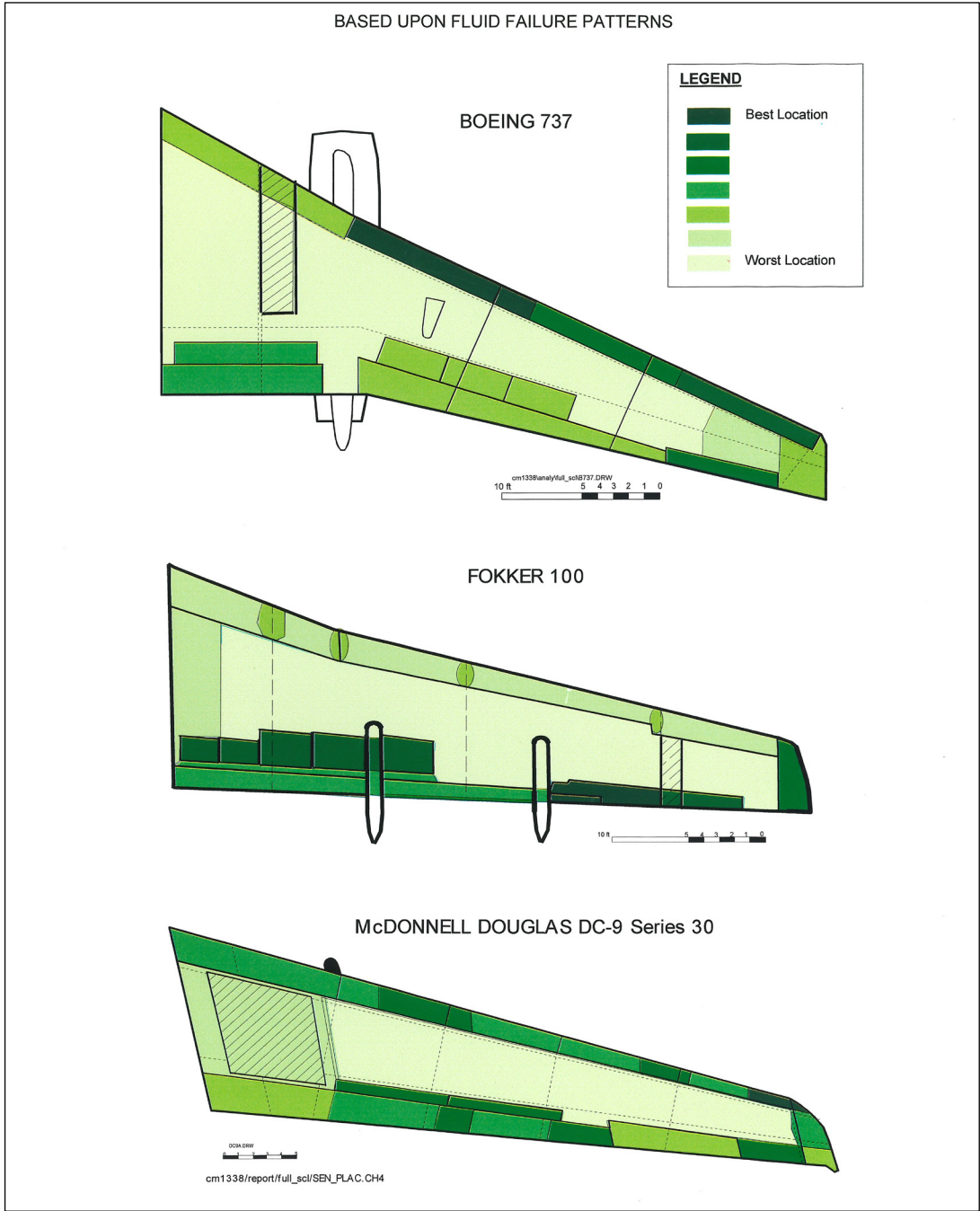
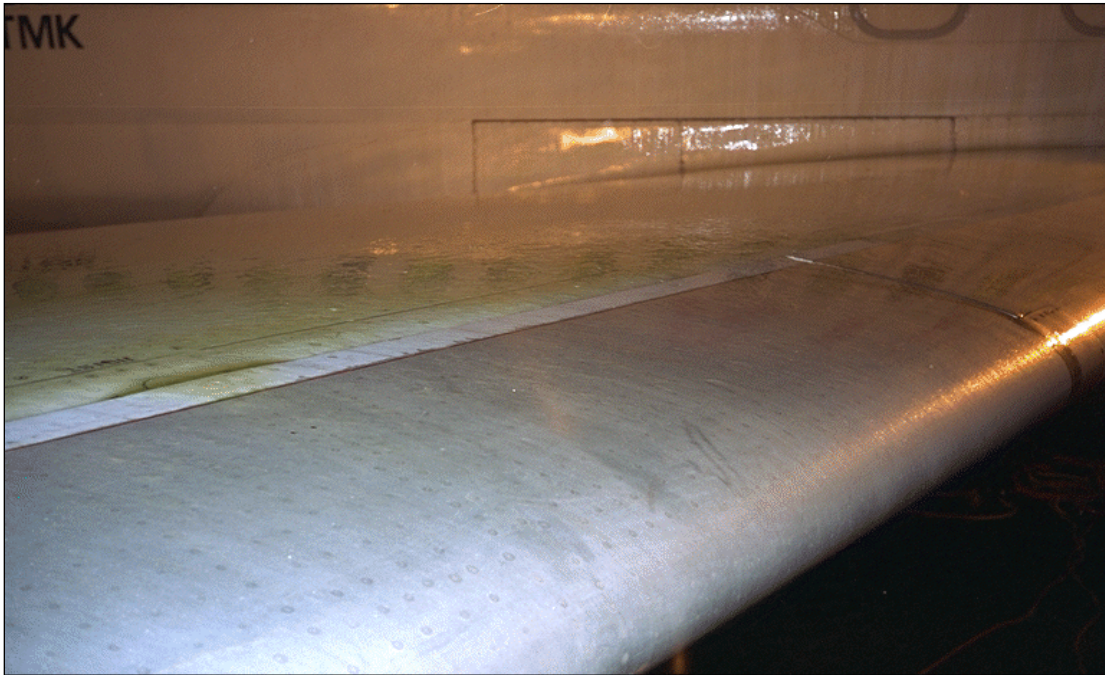


Figure 4.21: Preferred Locations for Sensor Placement

Photo 4.1: McDonnell Douglas DC-9 Wing Surface During Freezing Rain Tests at Dorval (Feb. 28, '96)

Prior to Failure (Type IV Fluid)



After Failure (no fluid was applied)

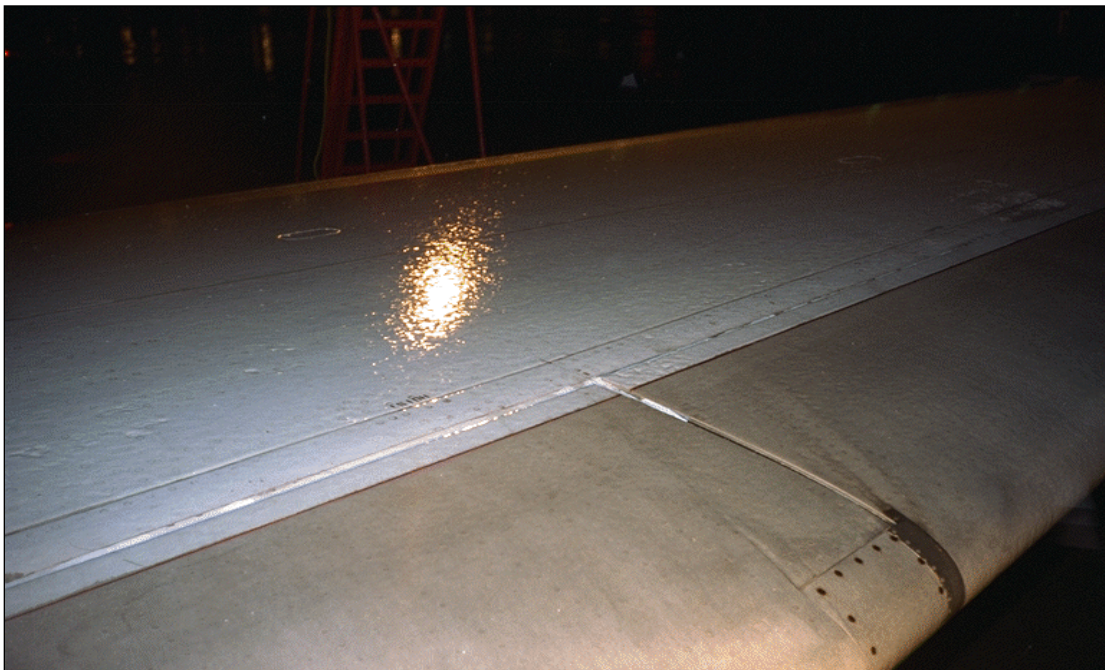
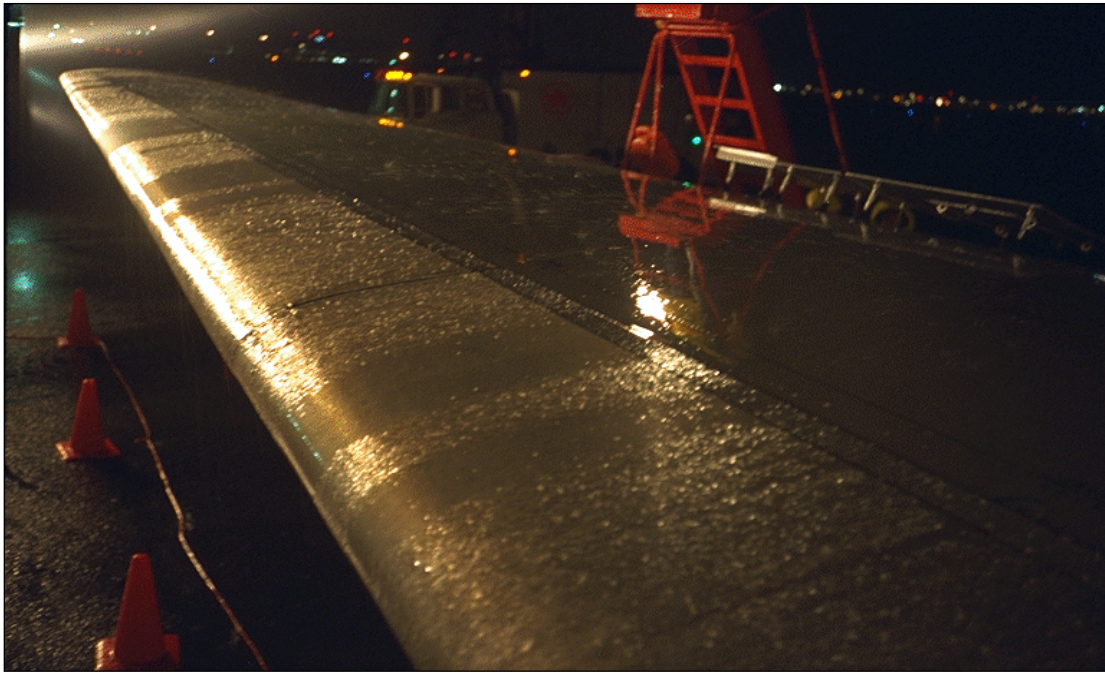


Photo 4.2: McDonnell Douglas DC-9 Wing Surface During Freezing Rain Tests at Dorval (Feb. 28, '96)

During Failure



Close-up of Failure on Leading Edge

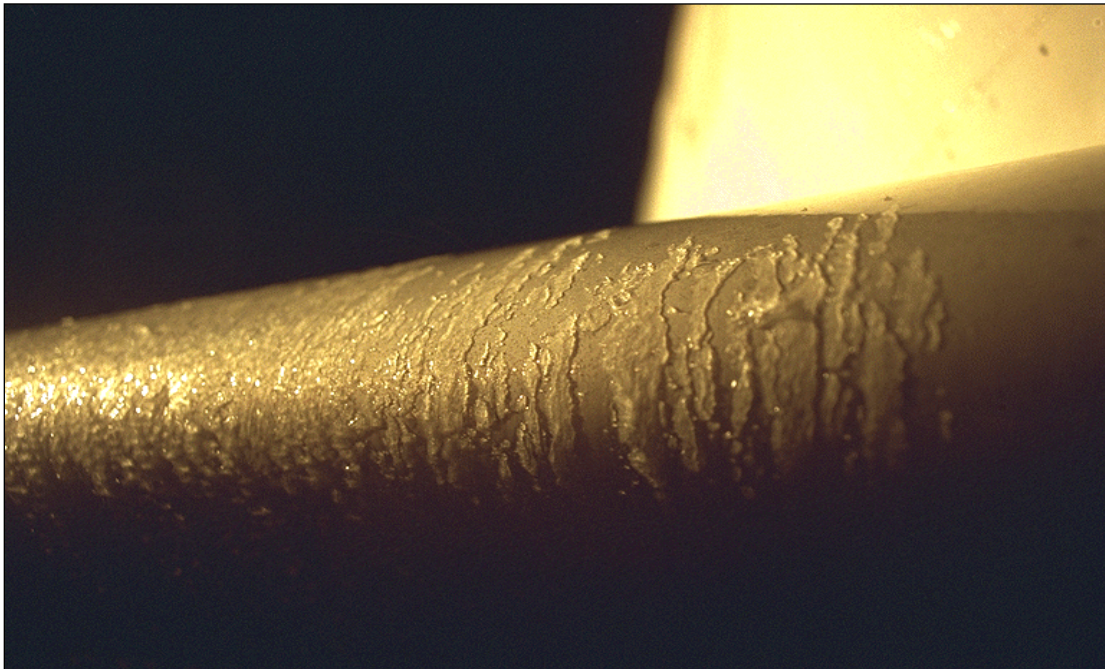


Photo 4.3: Type IV Freezing Rain Failures on Boeing 737 Wing

Outside Air Temperature: -3°C

Type IV fluid failure during ZR- is clearly visible on LE & TE.
 $t = 2:45 \text{ AM (+ 1 hr)}$, $T = -3^{\circ}\text{C}$, 25% of fluid on wing was failed.



ID # 24, Rate = $2 \text{ g/dm}^2/\text{hr}$, calm wind, Feb. 21, 1997, Ultra +

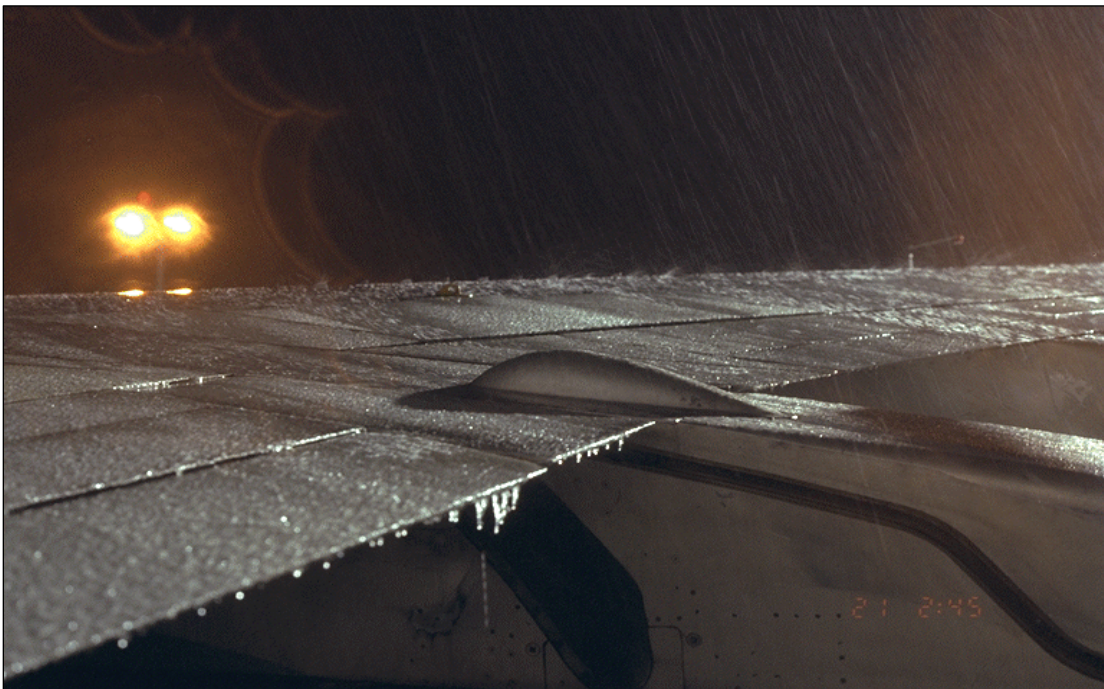


Photo 4.4: Type I Test, Light Freezing Rain Precipitation

OAT = -1.5°C, ID # 26, Rate = 25 g/dm²/hr, calm wind, Feb. 21, 1997, XL54
Type I Failure on Leading Edge



t = 3:26 AM, entire wing failed

Type I Failure on Main Wing which is not Apparent



t = 3:18 AM, 80% of wing failed

Photo 4.5: Type I Test on Boeing 737

OAT: 0.5°C

Trailing Edge Looks Failed (Overall Shot)



ID # 28, calm wind, Feb. 21, 1997, XL54, t = 4:01 AM

Detail and Tactile Check Shows Water



ID # 28, calm wind, Feb. 21, 1997, XL54, t = 4:03 AM

Photo 4.6: Comparison of Type I and Type IV Failure

Detailed View of Type I Failure



ID # 33, March 6, 1997, Fokker 100, 20 kph, t = 3:42 AM, failure occurred at 3:40 at this leading edge location

Detailed View of Type IV Failure



ID # 34, March 6, 1997, Fokker 100, t = 4:11 AM, 10% wing failure time was 4:10 AM, mid-wing, location 4

Photo 4.7: Snow Bridging Failures

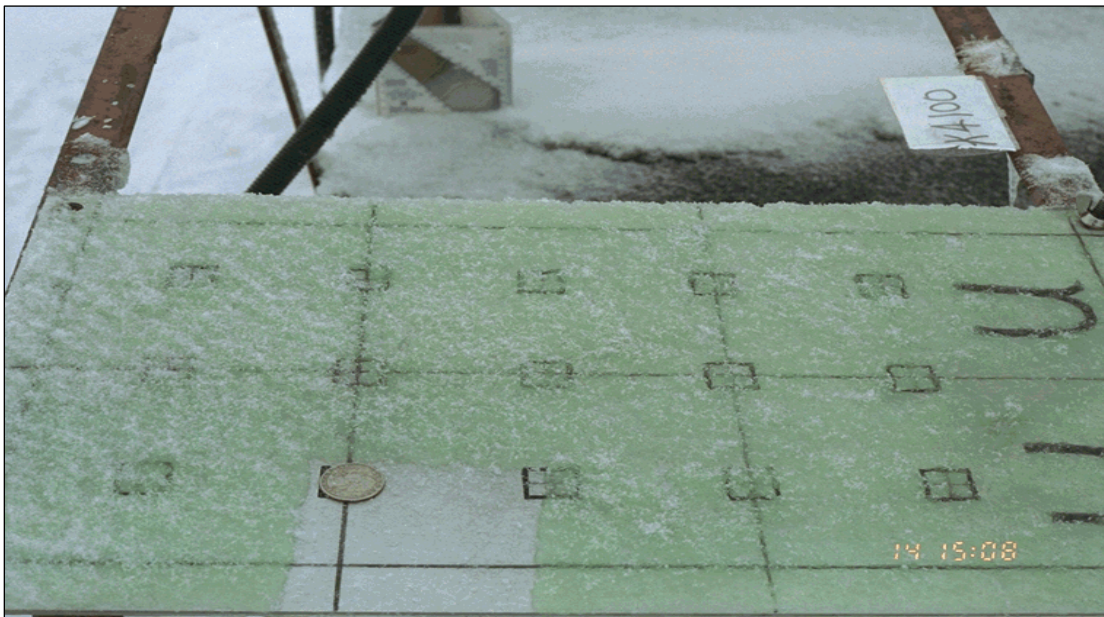
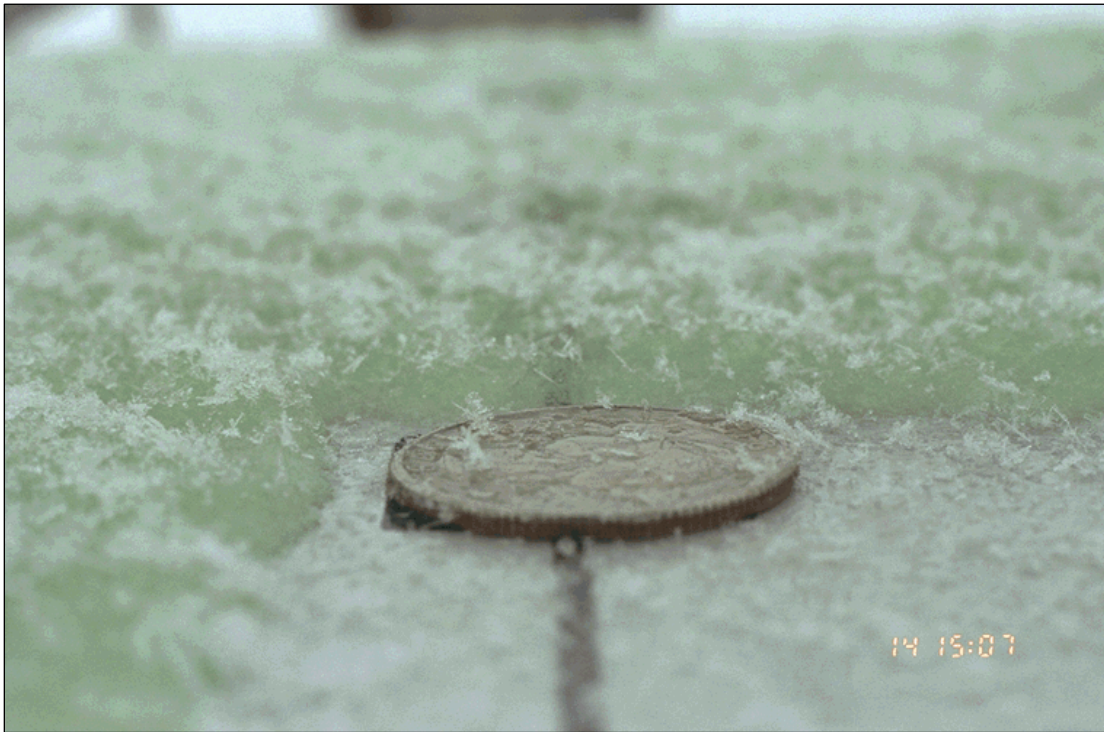


Photo 4.8: Fluid Failure Patterns on Fokker 100 Trailing Edge

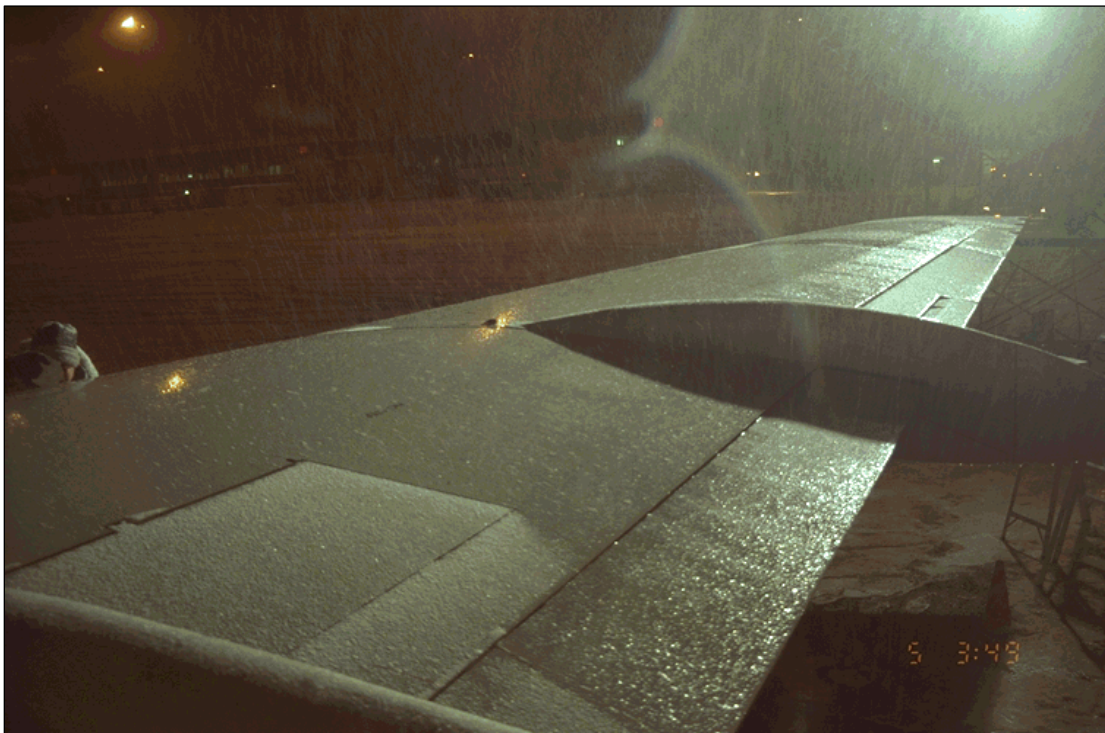


Photo 4.9: Examples of Photographs Used to Calculate Contamination Peak Height and Density

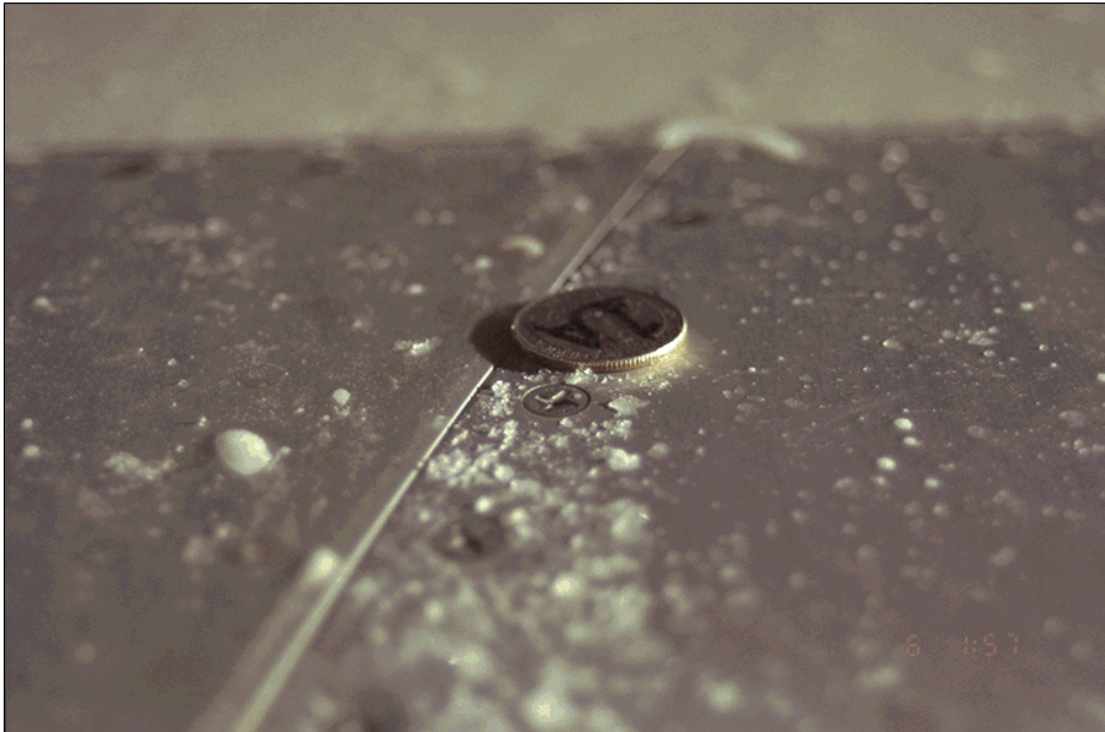


Photo 4.10: Appearance of Fluid Layer Prior to Propeller Run



Photo 4.11: Appearance of Fluid Following Propeller Run



Photo 4.12: Appearance of Fluid at Edge of Propeller Wash Area

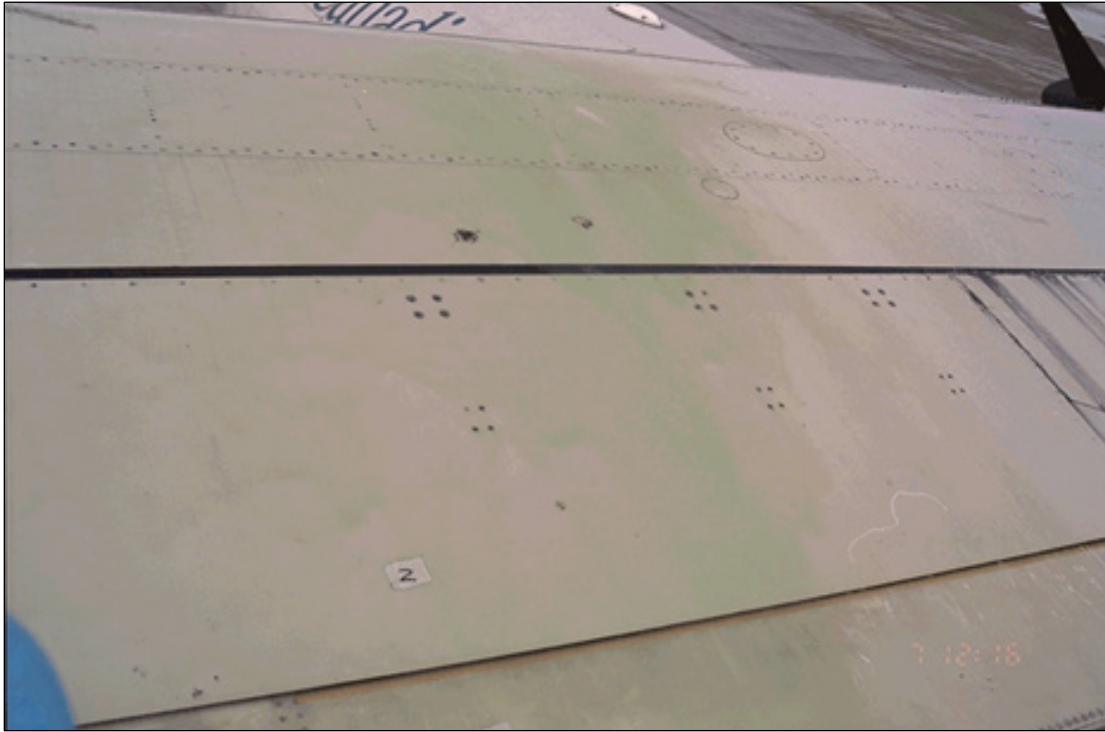


Photo 4.13: Appearance of Fluid in Propeller Wash Area



This page intentionally left blank.

5. DISCUSSION AND CONCLUSIONS

The following section is a point by point discussion of conclusions which resulted from testing, and is based on a thorough analysis of the data collected at that time.

5.1 Progression of Failure

i. Effect of aircraft type

Aircraft type, and more particularly wing design, do affect the progression of failure. Flight control systems such as ailerons, flaps, slats and spoilers are well defined sections of the aircraft wing, bounded by discontinuities. These discontinuities interrupt the flow of fluid onto the control surfaces from the main wing section and thus lead to local thinning and subsequent fluid failure at these locations. In general, the leading and trailing edges fail first, depending on aircraft type and wing design, followed by the mid-wing sections. This reflects the general reduction in fluid thickness at the leading and trailing edges due to gravity flow accelerated by dilution due to precipitation.

For aircraft with hard wing design, such as the Fokker 100, initial failures primarily occurred on the trailing edge, at the highest points of the ailerons and spoilers.

Aircraft with moveable surfaces on both the leading and trailing edges, such as the Boeing 737 and McDonnell Douglas DC-9, exhibited high occurrences of first failures and 10% failures, on both the leading and trailing edges, due to surface discontinuities at the control surfaces in these sections. Leading and trailing edge sections were the first to reach 100% failure, followed by the mid-wing sections.

ii. Effect of crosswind

On jet aircraft, downwind wings always failed prior to upwind wings in crosswind conditions. In fact, the downwind wing reached 10% wing failure, on average, 50% sooner than the upwind wing. For the Boeing 737, the outer section of the downwind wing failed first, and the inner section of the upwind wing failed first. Fokker 100 failures did not progress differently on upwind and downwind wings, however, the failure of the downwind wing for this aircraft type was still substantially accelerated by the crosswind.

Aircraft with high wing configurations are less likely to show pronounced failure differences between wings. For turboprop aircraft, results related to wind orientation were inconclusive at the time of report preparation.

iii. Comparison of tailwind and headwind

The first failure locations observed in tests conducted in tailwind and headwind conditions were different. In tailwind conditions, first wing failure occurs on the trailing edge, while in headwind conditions, leading edge failure was always present at the time of first failure. Failure progression is similar following first failure, regardless of the wind direction.

iv. Effect of wind speed

The effect of wind speed on the progression of failure was not determined, due to the insufficient number of tests.

v. Effect of precipitation rate, precipitation type and temperature

Several variables, such as precipitation type, rate of precipitation, and temperature were found to have an insignificant effect on the location of fluid failure and the progression of failure. These same variables do, however, effect the rate at which failures occur.

vi. Effect of fluid type

Although fluid type does not affect the pattern of progression of failure, failures progress more rapidly in Type I tests than in Type IV tests. This is demonstrated in the results from the examination of wing conditions five minutes after first failure. Type IV tests showed little or no difference in wing condition between first failure, and five minutes following first failure. For Type I tests, wings were 40% failed, on average, at five minutes following first failure.

vii. Effect of quantity of fluid

The quantity of Type IV fluid applied to a wing has an influence on the pattern of progression of failure. Failure progression is influenced by inadequate Type IV fluid application because failures often tend to initiate and propagate from the areas of light fluid application. Inadequate fluid application also results in reduced wing holdover times.

viii. Effect of propeller wash

The effects of propeller wash on the progression of failure for turboprop aircraft were not determined, due to the lack of adequate data.

5.2 Validity of the Representative Surface

The leading and trailing edges are the most failure-sensitive areas of aircraft wings, due to the interruption of fluid flow across the discontinuities associated with the slats, flaps, ailerons and spoilers. As a result, it would appear that any area selected to serve as representative should consider inclusion of the leading and trailing edges.

Because of the observed tendency of fluid to pool at the mid-chord section of the Boeing 737 and McDonnell Douglas DC-9, the representative surfaces should not include these areas.

The current location of the representative surface on the Fokker 100 as provided by Fokker proved valid.

5.3 Point Sensor Placement

The discussion related to point sensor placement is based on the use of early fluid failure locations as a criterion for determining ideal point sensor locations. Other criteria might dictate more suitable locations for sensor placement.

Sensor placement is most suitable on surfaces which display consistent failures. However, because many of these surfaces are located on moveable parts, sensors may have to be placed elsewhere on the wing. In this case, an algorithm for the sensor could be developed to predict the condition of the fluid on the wing, based on the condition of the fluid over the sensor head.

- The results of Boeing 737 tests showed that the leading and trailing edges would be good locations for sensor placement. The mid-wing leading edge has the highest occurrence of early failures and, as such, constitutes the best location for sensor placement. The outer sections of the leading edge and the aileron would also be acceptable locations. The middle of the wing exhibited the smallest occurrence of early failures, and is not considered to be an appropriate location for sensor positioning.
- The results of Fokker 100 tests illustrate that the best locations for sensor positioning (based on early fluid failure) are situated on the trailing edge, in particular the aileron and the spoiler panels. If sensor placement is required on the leading edge, sensors should be positioned in close proximity to the wing joints, since leading edge failures often propagate from these areas. The middle of the wing is not a suitable location for sensor placement on this aircraft.
- Sensor positioning on the McDonnell Douglas DC-9 is most appropriate on the outer wing leading edge, near the wing tip. The aileron is the next best location. In general, the entire leading and trailing edges would be suitable, since occurrences of early failures on these surfaces are common. Once again, the middle of the wing is the least suitable location for sensor positioning.

For reasons of safety, multiple sensors should be placed on each wing, in locations prone to failure. In crosswind conditions, upwind wings fail more slowly than downwind wings, therefore it is important that sensors be placed symmetrically on each wing of the aircraft.

5.4 Holdover Time Correspondence

Results from tests for Type I fluids conducted in 1996/97 show that flat plate holdover times correlate with observations of fluid failure patterns on aircraft wings when 10% of the wing area is covered with failed fluid. These results support previous APS Aviation findings from tests conducted in 1994/95 (1) and United Airlines tests in 1992/93 (3).

Results from Type IV anti-icing fluid tests conducted in 1996/97 show that flat plate holdover times are equivalent to failure levels on the wing approaching 15%. This number would appear to be reduced to 10% if all Type IV fluid applications were in accordance with fluid manufacturer specifications.

The results of a comparison of data points from Type I fluid on aircraft tests to the holdover time ranges substantiated by flat plate testing showed that all but one of the 10% wing failure points (conducted in natural snow and light freezing rain) were within, or above, the holdover time ranges for Type I fluid. The data point below the holdover time limit was a downwind test, and as a result, the wing probably experienced an increased rate of precipitation. This confirms, once again, that flat plates are good representations of 10% failed wings for Type I fluid.

The same comparison, for Type IV aircraft tests, showed that two 10% wing failure points were slightly below the holdover time ranges for Type IV fluid. In both cases, the fluid application was far from uniform. With proper fluid application, both points would probably be within, or above, the holdover time ranges, and would suggest a good correlation between flat plates and 10% wing failure.

Flat plates are good representations of Fokker 100 ailerons and spoilers. Holdover times of these surfaces are similar to those substantiated by flat plate testing.

5.5 Appearance of Fluid Failure

The tests conducted in the past year lead to the conclusion that the appearance of fluid failure can vary under different conditions. Tests performed in freezing drizzle and light freezing rain demonstrated that failure detection in these conditions can be difficult, and that the appearance of failure seems to be affected by the ambient temperature. The appearance of Type I and Type IV failures, in natural snow tests

on aircraft wings, was also shown to be different. The difficulty in determining failures particularly in freezing rain conditions emphasizes the importance of advancing research related to the operational use of wing surface sensors, and remote ice detection sensors.

Photo and video evidence of full-scale tests were recorded and are available on CD ROM for training purposes.

5.6 Evaluation of Roughness

A method was developed to evaluate the roughness of a failing fluid at different points during the failure process. Photo and video procedures were amended during the 1996/97 test season to enable close-up photography of wing failures. Photo and video evidence of all stages of testing have been documented by APS Aviation, and could be used in the production of future roughness models.

A roughness model was developed and provided to the National Research Council, where analyses of the effects of the roughness due to the failed fluid were performed. Computer simulations were conducted to evaluate the aerodynamic lift penalties related to the density and size of the contamination on the wing surface, and the results of these studies will be published by the National Research Council.

5.7 Pilots' Field of View

A catalogued series of photos of areas of the wing that are visible from the aircraft, was developed for the Boeing 737, Airbus A320, ATR 42, and Fokker F28 aircraft, and is presented in Appendix F.

Photos to date illustrate that viewing from any single window in the aircraft has limited effectiveness, but that moving to another location can provide a view of the remainder of the wing. During deicing, cabin windows frequently become covered with fluid and adhering snow, which can obscure visibility.

The use of binoculars provided a much enhanced view of details on the wing surface.

5.8 Fluid Thickness Measurement

The rate of Type IV fluid thinning was similar to that observed during previous winter tests, reaching a stable thickness in about 15 minutes.

The fluid profile over the Boeing 737 wing was similar to that of other jet aircraft measured in the previous study.

Heating of Type IV fluid was observed in deicing vehicles having fluid storage tanks sharing a common metal wall. During flat plate tests, heating has been observed to have a detrimental effect on fluid thickness for some brands of Type IV fluid.

On propeller aircraft, both Type I and Type IV fluids thin significantly in the core of the propeller blown area. Type I fluid is blown laterally, and forms a ridge of thicker fluid on the wing surface in the area directly behind the limit of the propeller circumference.

Application of ice-phobic products on wing surfaces, such as Ice Ex II, appears to cause rapid run-off and beading of Type I fluid. The interaction of an ice-phobic treated surface with various fluids, and the consequential influence on overall anti-icing protection, requires investigation.

Fluid thickness measurements were not obtained on Canadair Regional Jet, Fokker 100 or DHC Dash 8 aircraft. Previous preliminary trials on the Canadair Regional Jet aircraft had indicated that fluid on the leading edge thinned very rapidly to an exceptionally thin layer, leading to recommendations of further investigation, which have not yet been satisfied due to non-availability of aircraft during periods of freezing precipitation.

5.9 Fluid Application Techniques

The quality of the application of Type IV fluid varied greatly among various spray technicians. This is believed to be a problem common throughout the aviation industry, and not confined to one airport, nor to the operators who cooperated in these trials.

The detrimental influence of poor quality of spray application, characterised by non-uniform initial thickness distribution, on resultant holdover times was observed and noted.

Trials on fluid application showed that the quality of fluid application is very sensitive to spray technique. Depending on the spray technician, acceptable results can be achieved with a standard Type I nozzle, and unacceptable results can be provided with a nozzle designed specifically for Type II and Type IV fluids.

Trials demonstrated, in general, that the closer the nozzle is to the wing surface, the better the result achieved. The most consistent fluid applications were achieved

through adjusting the nozzle to provide a wide fan-shaped spray pattern, with low fluid flow. Good driver/sprayer coordination is essential.

In order to obtain the best end result, the spray technician must accommodate wind speed and direction by locating and adjusting the nozzle accordingly. This technique appears to be best learned through experience, and is dependant upon the spray technician having a clear understanding of the nature of Type IV fluid, and of the application result desired.

Training, specific to application of Type IV fluid, is needed, and should include educating spray technicians on the peculiarities of Type IV fluids, and how they provide anti-icing protection.

A video presentation on quality of fluid application has been received with interest, and a number of copies of the video have been provided to carriers, ground handlers, fluid manufacturers, and equipment manufacturers upon their request.

5.10 Test Methodology

Initial test methodology proved to be fundamentally sound. Certain refinements were found to be necessary during the actual conducting of tests. These have been recorded to support the evolution of test procedures for future test programs.

This page intentionally left blank.

6. RECOMMENDATIONS

The following section provides a series of detailed recommendations based on testing results and conclusions, some of which were discussed at length in the previous section of this report.

6.1 Progression of Failure

Thickness tests, conducted in 1995/96 on the Canadair Regional Jet (see TP 12900), indicated that fluid appeared to thin very rapidly on the leading edge, and recommended further tests to investigate this phenomenon. These tests were not conducted during the 1996/97 winter due to non-availability of the aircraft.

Results from the single test session, conducted on a high wing turboprop aircraft (the ATR 42) in 1996/97, proved to be inconclusive.

All failure progression tests conducted thus far have employed the same brand of Type IV fluid.

It is recommended that:

- Further failure progression tests be conducted, on the Canadair Regional Jet, and on either the ATR 42 or the DHC Dash 8;
- Further failure progression tests be conducted using other brands of Type IV fluid, in order to identify any differences in fluid performance and behaviour on aircraft wings;
- For future tests conducted in crosswind conditions, the effective rate of precipitation on both wings should be measured; and
- Since it has been shown that crosswind conditions and wing dihedral affect the progression of failure, future crosswind tests should be performed on a high-wing aircraft with anhedral wings, such as the BAe 146.

6.2 Location of Representative Surface/Sensor Placement

The factors derived from aircraft full-scale fluid failure and fluid thickness testing which are relevant to decisions governing the placement of representative surfaces on aircraft wings are: failures normally initiate and progress from the leading and trailing edges; downwind wings fail prior to upwind wings in crosswind conditions; and, the best location for representative surfaces are aircraft specific.

It is recommended that:

- Both the leading and trailing edge be considered in the determination of the representative surface; and
- If point detection sensors are installed on an aircraft, sensors should be positioned on both wings.

6.3 Value of Ice Sensors in the Deicing Operation

Tests on wing surfaces demonstrated that failure detection is very difficult in certain conditions.

It is recommended that:

- Research related to the operational use of wing contamination sensors and ice detection cameras be continued; and
- A series of tests should be conducted to examine the condition of aircraft wings at the hold point, just prior to entering the take-off runway, during snow storms and other natural freezing precipitation events.

6.4 Appearance of Fluid Failure

Difficulties encountered in fluid failure detection for certain freezing precipitation conditions indicate this aspect to merit further investigation. Pilots and ground staff require better information and training on the recognition of visual clues to fluid failure.

It is recommended that:

- A series of tests on flat plates be conducted in order to document the appearance of fluid failure, and the physical condition of the fluid; and
- An educational document be developed, based on the results of the foregoing tests and results from tests in previous programs, to train and educate both pilots and ground deicing staff. This document could form the basis of a computer-based training module.

6.5 Evaluation of Roughness

A fluid roughness model was developed for the Fokker 100 aircraft, an aircraft where fluid failures are concentrated on the trailing edge. A model for aircraft that experience failures on the leading edge would be useful. Models for upwind and downwind wings in crosswind conditions could also be considered.

It is recommended that:

- Additional fluid roughness models be developed for aerodynamic evaluation by the National Research Council of Canada;
- Development of these models should consider failures at different levels of progress (wing first failure, 10%, 25%, 50%); and
- Development of these models should also consider failures on upwind and downwind wings in crosswind conditions.

6.6 Pilots' Field of View

Photo documentation of pilots' field of view proved useful in understanding the challenge of identifying fluid failures from inside the aircraft.

It is recommended that:

- Photo documentation be developed on additional aircraft types. This documentation should include the appearance of aircraft wings in lighting conditions which are typical of that experienced while holding prior to take-off during snowfall and other freezing precipitation events.

6.7 Fluid Thickness Measurement

It is recommended that:

- Fluid thickness measurements be conducted on the Canadair Regional Jet, Fokker 100, and DHC Dash 8 aircraft;
- Interaction of ice-phobic products with deicing and anti-icing fluids be investigated for overall impact on wing protection; and
- Thickness measurements be conducted on other commercial brands of Type IV fluid which are applied on aircraft wings.

6.8 Fluid Application Techniques

It is recommended that:

- Deicing operators be encouraged to continue improving the quality of Type IV fluid application. This may be achieved by providing advice to the aviation community on the detrimental influence of poor fluid application, and by providing support material for training;
- Use of ice detection cameras (such as the Spar/Cox camera) be investigated, and its use encouraged in the training of spray technicians during qualification programs;
- Investigation be conducted to determine how to best use icing sensor cameras (such as the RVSI and Spar/Cox camera) to support and confirm the quality of the fluid application during line operations; and
- Operators be made aware of the detrimental influence that heating exerts on the fluid thickness values (and holdover time) of some brands of Type IV fluid.

6.9 Evolution of Test Methodology

The test procedures proved to be fundamentally sound. Some refinements were found to be necessary, and these are documented in this report. It is recommended that:

- Procedures for future tests address challenges, and incorporate the refinements and enhancements identified in this report; and
- As a means of reducing the costs related to the full-scale test program, the feasibility of conducting future full-scale tests on aircraft wing sections should be explored.

REFERENCES

1. D'Avirro, J., *Aircraft Full-Scale Test Program for the 1995-1996 Winter – Type IV*, APS Aviation Inc., Transportation Development Centre, Montreal, October 1996, TP 12901E, 50.
2. Boutanios, Z., D'Avirro, J., Dawson, P., *Aircraft Full-Scale Test Program for the 1994-1995 Winter*, APS Aviation Inc., Transportation Development Centre, Montreal, December 1995, TP 12595E, 90.
3. Chan, G., Cleary, C., D'Avirro, J., Foo, H., *Aircraft Ground De/Anti-icing Fluid Holdover Time Field Testing Program for the 1992-1993 Winter*, APS Aviation Inc., Transportation Development Centre, Montreal, October 1993, TP 11836E, 122.
4. D'Avirro, J., *Aircraft Ground De/Anti-icing Fluid Holdover Time Field Testing Program for the 1995-1996 Winter*, APS Aviation Inc., Transportation Development Centre, Montreal, November 1996, TP 12896E, 171.
5. Chaput, M., D'Avirro, J., Dawson, P., Hanna, M., Peters, A., *Aircraft Ground De/Anti-icing Fluid Holdover Time Field Testing Program for the 1996/97 Winter*, APS Aviation Inc., Transportation Development Centre, Montreal, October 1997, TP 13131E, 234.
6. D'Avirro, J., Dawson, P., *Evaluation of Fluid Thickness to Locate Representative Surfaces*, APS Aviation Inc., Transportation Development Centre, Montreal, October 1996, TP 12900E, 109.

This page intentionally left blank.

APPENDIX A

TERMS OF REFERENCE – WORK STATEMENT

TRANSPORTATION DEVELOPMENT CENTRE

WORK STATEMENT

**AIRCRAFT AND FLUID HOLDOVER TIME TESTS FOR WINTER 96/97
(Short Title: Winter Tests 96/97)
(November 1996)****1 INTRODUCTION**

Following the crash of a F-28 at Dryden in 1989 and the subsequent recommendations of the Commission of Inquiry, the Dryden Commission Implementation Project (DCIP) of Transport Canada was set up. Together with many other regulatory activities an intensive DCIP research program of field testing of deicing and anti-icing fluids was initiated with guidance from the international air transport sector through the SAE G-12 Committee on Aircraft Ground De/Anti-icing. As a result of the work performed to date Transport Canada and the US Federal Aviation Administration (the FAA) have been introducing holdover time regulations and the FAA has requested that the SAE, continue its work on substantiating the existing ISO/AEA/SAE Holdover Time (HOT) tables (DCIP research representing the bulk of the testing).

The times given in HOT Tables were originally established by European Airlines based on assumptions of fluid properties, and anecdotal data. The extensive testing conducted initially by the DCIP R&D Task Group and subsequently by Transport Canada, Transportation Development Centre (TDC), which has taken over the functions of the DCIP, has been to determine the performance of fluids on standard flat plates in order to substantiate the times, or if warranted, to recommend changes.

DCIP has undertaken most of the field research and much other allied research to improve understanding of the fluid HoldOver Times. Most of the HOT table cells been substantiated, however low temperatures have not been adequately explored and further tests are needed.

The development of ULTRA by Union Carbide stimulated all the fluid manufacturers to produce new long lasting anti-icing fluids defined as Type IV. All the Type IV fluids were upgraded in early 1996 and therefore all table conditions need to be re-evaluated and the table revised if necessary. Certain special conditions for which advance planning is particularly difficult such as low temperatures with precipitation, rain or other precipitation on cold soaked surfaces, and precipitation rates as high as 25 gm/dm²/hr need to be included in the data set. All lead to the need for further research.

Although the Holdover tables are widely used in the industry as guides to operating aircraft in winter precipitation the significance of the range of time values given in each cell of the table is obscure. There is a clear need to improve the understanding of the limiting weather conditions to which these values relate.

An important effort was made in the 94/95 and 95/96 seasons to verify that the flat plate data were representative of aircraft wings. Airlines cooperated with DCIP by making aircraft and ground support staff available at night to facilitate the correlation testing of flat plates with performance of fluids on aircraft. An extension of this testing was to observe patterns of fluid failure on aircraft in order to provide data to assist pilots with visual determination of fluid failure failure, and to provide a data to contamination sensor manufacturers. The few aircraft tests made to validate the flat plate tests were inconclusive and more such tests are needed. Additional tests testing with hot water and with hot air for special deicing conditions were not completed. All these areas are the subjects for the further research that is planned for the 96/97 winter.

2 PROGRAM OBJECTIVE (MCR 16)

Take an active and participatory role to advance aircraft ground de-icing/anti-icing technology. Develop international standards, guidance material for remote and runway-end de-icing facilities, and more reliable methods of predicting de-icing/anti-icing hold-over times.

3 PROGRAM SUB-OBJECTIVES

- 3.1 Develop reliable holdover time (HOT) guideline material based on test information for a wide range of winter weather operating conditions.
- 3.2 Substantiate the guideline values in the existing holdover time (HOT) tables for fluids that have been qualified as acceptable on the basis of their impact on aircraft take-off performance.
- 3.3 Perform tests to establish relationships between laboratory testing and real world experience in protecting aircraft surfaces.
- 3.4 Support development of improved approaches to protecting aircraft surfaces from winter precipitation.

4 PROJECT OBJECTIVES

- 4.1 To complete the substantiation of holdover time tables and evaluate those parameters that may reduce holdover times for currently available and properly qualified, SAE deicing and anti-icing fluids (Types I,II,III and IV).
- 4.2 To collect weather data on winter storms at airports and to assess the precipitation, wind and temperature values that bound the holdover time ranges given in the tables.
- 4.3 To develop a procedure for evaluating fluid dry out characteristics and to determine the dry-out characteristics of fluids.
- 4.4 To determine the influence of fluid type, precipitation and wind on location and time to fluid failure initiation, and also failure progression on service aircraft .

5. DETAILED STATEMENT OF WORK

5.1 Planning and Preparation

5.1.1 Program management

The work shall be broken down into the distinct areas of activity consistent with the project objectives.

A detailed workplan, activity schedule, cash flow projection, project management control and documentation procedure shall be developed and delivered to the TDC project officer for approval within one week of effective start date.

5.1.2 Coordination

Prepare, plan, and coordinate with personnel from TDC, airlines, airport authorities, fluid manufacturers, Instrumentation suppliers, and the National research Council of Canada (NRC) with respect to site requirements and test procedures; training of test personnel; conduct of dry-run(s) under no-precipitation conditions; and conduct of tests.

5.1.3 Safety of Personnel and Aircraft

Planning shall include precautions to ensure safety of personnel, and safety (freedom from damage) of aircraft.

A safety officer shall be nominated to prepare an appropriate plan, and monitor its implementation.

Conduct of tests shall respect OSHA standards, Quebec CSST standards and applicable sections of the Canadian and Quebec labour codes. Where exceptions are taken due to the nature of the work, e.g. emplacement of power and instrumentation cables in the work area, test personnel shall be made aware of potential hazards.

Within the work area, comprising the de-icing pad and access ways, test personnel shall co-ordinate their movements and be made aware of all other operations taking place. Movement of airline equipment - aircraft, tow trucks, de-icing trucks, shall have precedence over test personnel activities. Care shall be taken to ensure that mobile equipment, such as inspection platforms, lighting stands etc. are not in contact with aircraft surfaces. Potential contact points for such equipment shall be padded. Movements of visitors and personnel not directly involved in tests at any given time shall be tightly controlled, with safety as the governing criteria. Obtain 'Airport owners and operators premises and products liability insurance' to indemnify and hold harmless the airport and the operators against any claim arising.

5.2 Substantiation of HoldOver Time Tables

5.2.1 Site preparation.

Set up experimental sites and install sensors as inspection aids to provide consistent plate failure conditions under field and laboratory conditions.

5.2.2 Completion of substantiation of existing Type I and Type II SAE holdover time tables at very low temperatures.

Conduct flat plate tests under conditions of natural snow precipitation to substantiate the existing Type I holdover time table at temperatures below -10°C . Tests shall be conducted at temperatures as low as possible. Tests shall be conducted with at least two different manufacturers fluids, one propylene glycol and one ethylene glycol.

Conduct flat plate tests under conditions of natural snow precipitation to confirm the existing Type II holdover time table at temperatures between -14°C and -25°C , and to substantiate the existing Type II holdover time table at temperatures below -25°C . Tests shall be conducted down to the lowest temperatures experienced in the field consistent with maintenance of a 7°C buffer for each fluid tested. Tests shall be conducted with at least three different manufacturers fluids.

Planning shall be based on conduct of tests at Dorval Airport, Montreal. consideration shall be given to conduct of alternate test sites where the required test conditions may occur more frequently.

5.2.3 Evaluation of HoldOver Time performance of qualified Type III fluids; and Creation of a generic Type III Holdover time table.

Conduct flat plate tests under conditions of natural precipitation and in the laboratory to establish the holdover time performance of qualified Type III fluids.

Create a generic Type III HoldOver Time table in consultation with TDC.

5.2.4 Substantiation of Type IV fluids.

Conduct flat plate tests under conditions of natural precipitation and in the laboratory to substantiate the performance of new Type IV fluids over the full range of Holdover time characteristic conditions. Four new Type IV fluids are presently anticipated.

5.2.5 Review of 'Buffer' Temperatures

Note: The guidelines for holdover times given in the SAE Tables call for the freezing points of fluid mixtures to be at least 10°C (18°F) for Type I, and 7°C (13°F) for Type II below the ambient air temperature.

Review, from an operations standpoint, the components which contribute to these requirements including the effects of imprecise initial fluid mixture strength, discrepancies between nominal ambient temperature and actual temperature at the aircraft, discrepancies between ambient temperature and wing temperature, and possible precipitation accumulation where applicable. An independent reviewer will conduct a separate review of 'Buffer' temperatures oriented towards an evaluation of the properties of de/ant-icing fluids.

Prepare recommendations in cooperation with the independent reviewer and with TDC for possible revisions to the buffer temperatures for frost removal, for aircraft protection at very low temperatures, and to the 'lowest operational use temperature'.

5.2.6 Preparation of HoldOver Time Tables

Prepare draft revised Holdover Time tables for discussion at SAE Holdover Sub-committee meetings. Prepare presentation material for dissemination at SAE G-12 Committee meetings.

5.2.7 Presentation of findings

Participate at the SAE meeting to be held in Pittsburgh in June 1997, and present the results of the HoldOver Test work conducted during the winter season 1996/97.

5.3 Assembly of Weather Data

Assemble weather data from READAC, field measurements, and other data sources taken over several seasons for winter storms at airports for assessment of the precipitation, wind and temperature values that correspond to the limiting values given in the holdover time tables.

Data shall be assembled in a coherent electronic format, for use by others, to establish the combinations of precipitation, wind and temperature values that delimit holdover times.

5.4 Fluid Dry-Out Characteristics

5.4.1 Development of a Potential Test Procedure

Identify a potential procedure for testing the dry out characteristics of fluids using a simulated winter climb-to-altitude environment.

Base the procedure on use of a de-pressurization chamber such as that available at the Centre de Recherche Industriel du Québec (CRIQ), or equivalent.

The procedure shall take into account action to be taken in the event that pressure and temperature cannot both correspond to a typical aircraft ascent path.

5.4.2 Characteristics of Fluids

Describe the dry-out characteristics of sample qualified Type II fluids to provide a benchmark for comparative evaluation of new fluids.

Determine the dry out characteristics of Type II and Type IV fluids.

Photographic coverage shall be provided where appropriate.

5.4.3 Acceptance Criteria

Review with aircraft operators the effects of contamination (e.g. residual grease, dirt, and ice) in 'aerodynamically quiet areas' on aircraft critical surfaces such as flap tracks, etc. Report on the significance of such contamination as it affects equipment operation, and as it affects maintenance.

Develop a tentative fluid dry-out acceptance criteria in conjunction with TDC.

5.4.4 Review and Coordination Meetings

Participate in review and coordination meetings with TDC and with the Université du Québec à Chicoutimi, Anti-icing Materials International Laboratory (AMIL) where similar work is being undertaken.

5.5 Aircraft Full Scale Tests

5.5.1 Purpose of tests

Conduct full scale aircraft tests:

- to generate data which can be used to assist pilots with visual identification of fluid failure failure;
- to assess a pilot's field of view during adverse conditions of winter precipitation for selected aircraft;

- to assess whether Representative Surfaces can be used to provide a reliable first indication of anti-icing fluid failure;
- to explore the potential application of point detection sensors to warn the Pilot in Command (P.I.C.) of an 'unsafe to take-off condition';
- to obtain failed fluid contamination distributions and profiles which can serve as inputs to a theoretical program designed to assess the effects of such contamination on possible aircraft take-off performance; and
- to compare the performance of de/anti-icing fluids on aircraft surfaces with the performance of de/anti-icing fluids on flat plates.

5.5.2 Test Locations

Conduct tests at Dorval International Airport, Montreal and Pearson International Airport, Toronto using aircraft made available by airlines. Contingency plans shall be made to conduct tests at alternative sites: Ottawa, Uplands Airport; Quebec City, Ancienne Lorette Airport.

5.5.3 Facilities to be Provided

Provide all necessary equipment and facilities for conduct of the tests. Negotiate provision of ancillary equipment and services where possible with the pertinent airlines. Notify TDC of such arrangements. Equipment shall include lighting fixtures as necessary, observation platforms, vehicles, storage facilities, office facilities and personnel rest accommodation. Additional facilities and test equipment, if required, may be requested subject to agreement by all parties involved.

5.5.4 Test Plans

Prepare Test Plans for full-scale aircraft tests to include the following:

- a) A detailed statement of work for each of the participants;
- b) A specific test plan, for review by all parties, which will include as a minimum:
 - Schedule and sequence of activities;
 - Detailed list of responsibilities;
 - Complete equipment list;
 - List of data, measurements and observations to be recorded; and
 - Test procedures.
- c) A list of test activities including:
 - Visual and Instrumented Data Logging;
 - Monitoring and recording environmental conditions, including:
 - Air temperature,
 - Wing surface temperature at selected locations,

- Wind velocity and direction, and
- Precipitation type and rate;
- Record of aircraft and plate orientation to the wind; and
- Use of instrumentation to determine the condition of the fluid.

d) Data to be acquired from the tests including:

- Identification of fluid failure criteria;
- Location of first point of fluid failure on the wing, and subsequent failure progression;
- Correlation of fluid failure time to environmental conditions;
- Correlation of fluid failure times on flat plates and aircraft; and
- Behaviour of fluid on the "representative" surface.

Develop a procedure for concurrent comparison testing of fluids under conditions of natural freezing precipitation on flat plates and on aircraft.

Present plans for review and approval by the TDC project officer.

Present the approved program to the airline involved prior to the start of field tests.

5.5.5 Test Scheduling

Schedule tests on the basis of forecast freezing precipitation.

Notify the airline in advance of the desired test set-up, including aircraft orientation with respect to the forecast wind direction, sequence of fluid applications, and any additional services requested.

Confirm that the de-icing equipment used for the tests is equipped with a nozzle suitable for the application of the pertinent fluids. Application of fluids will be by airline personnel.

5.5.6 Personnel and facility preparation

Recruit and train local personnel who will conduct test work.

Secure necessary approvals and passes for personnel and vehicle access for operation on airport airside property.

Provide all equipment and all other instrumentation necessary for conduct of tests and recording of data.

Arrange (with the cooperation of TDC) for deicing equipment and aircraft to be made available for the tests .

Arrange for the provision of fluids for spraying an aircraft. Where possible fluids shall be supplied by the original fluid manufacturer to the operators on a replacement basis either directly or through intermediaries.

Arrange for spray application during the initial tests to be observed by the fluid manufacturer's representative for endorsement.

5.5.7 Aircraft, De-Icing Pads and Crews

Planning shall be based on the following aircraft and facilities:

<u>Aircraft</u>	<u>Airline</u>	<u>Test Locn.</u>	<u>De-Icing Pad</u>	<u>De-Icing Crew</u>
Fokker 100	American	Dorval	West	American
Canadair RJ	Comair	Dorval	West or East	Delta
Boeing 737	Canadian	Dorval	South or East	Canadian
ATR 42	Cdn. Regl.	Dorval	East	-
D-H DASH-8	Cdn. Regl.	Toronto	N/A	-

(or Ottawa)

5.5.8 Dry Runs

Conduct a 'dry run' for test team personnel to ensure familiarity with their requested roles. Dry runs shall be scheduled as early in the winter season as can reasonably be achieved and shall be scheduled at the participating airline's convenience. Operations shall include Type I and Type IV fluid applications and re-orientation of the aircraft.

5.5.9 Full-Scale Tests

Conduct 8 full all-night test sessions.

Note: In general, aircraft will be made available for testing outside regular service hours, i.e. available between 23:00 hrs. and 06:00 hrs. Subject to weather conditions additional test sessions may be requested.

Tests shall be conducted under the following conditions:

- Aircraft orientations: Headwind, Crosswind, Tailwind
- Precipitation: Snow, Freezing drizzle (If possible)
- Fluids: Type I (Predominantly), Type IV
- Engine Operations: Anticipate dry run & full scale tests with engines running for Turbo-prop aircraft.

The following matrix of tests is anticipated:

<u>Aircraft</u>	<u>No. of Tests</u>	<u>A/C Orient's*</u>	<u>Comments</u>
Fokker F-100	1	T, C, H	Dry Run
Fokker F-100	2	T, C, H	Test F-100 & RJ in common if possible
Canadair RJ	2	T, C, H	
Boeing 737	2	T, C, H	
ATR 42	1	T, C, H	Engines running
D-H DASH-8	1	T, C, H	Engines running

Total Tests 8 + 1 dry run

T = Tail Wind, C = Cross- Wind, H = Head Wind

5.5.10 Priority of Tests

Initial planning for tests shall be based on the matrix of tests covered by items 5.5.7 and 5.5.9, above.

Plans shall be made such that the number of tests with each aircraft and sequence of tests can be easily revised.

5.5.11 Aircraft Orientation and Fluid Application:

Tests shall be conducted in the following sequence: Tail to wind, Cross wind, Head wind.

For tests with Tail to wind and Nose to wind, Type I fluid shall be applied to the port wing, and Type I fluid followed by Type IV fluid shall be applied to the starboard wing in a standard 2-step application procedure. Tests with Type I fluid, only, shall be repeated without change in aircraft orientation until failure of the Type IV fluid.

For cross-wind tests both wings shall be treated with Type I only and observations of fluid behaviour made through to failure of the fluid on both wings.

Under conditions of light precipitation when the expected time to failure of the Type IV fluid is judged to be 'excessive' the Type IV test shall be aborted, and the aircraft re-orientation shall proceed for further Type I tests.

Under conditions of heavy precipitation when the expected time to failure of the Type IV fluid is judged to be 'short', Type IV test(s) shall also be conducted in a cross-wind, with the same fluid application to both wings.

A maximum of three (3) Type I tests and one Type (IV) test are contemplated for each orientation, on a given test night.

5.5.12 Tests with Turbo-Prop Aircraft.

True functional tests with Turbo-prop aircraft; DeHavilland Dash 8 and ATR-42, require that the engines should be running.

Gather available information applicable to the ground operations of these aircraft in regular service. Based on observation and the observations of others, assess the influence of propeller 'wash' on fluid flow-back patterns, and on precipitation behaviour, particularly under cross wind conditions.

Only one test series, each, shall be conducted with these aircraft, and particular consideration shall be given to safety. In the event of conflict between access for data gathering to obtain required test results and safety considerations, safety shall govern.

5.5.13 Test Measurements

Make the following measurements during conduct of each test:

Contaminated thickness histories at points on wings, selected in cooperation with TDC.

Contamination histories at points on wings to be selected in cooperation with TDC.

Location and time of first failure of fluids on wings -

Concurrent measurement of time to failure of fluids on flat plates; plates to be mounted on standard frames and on aircraft wings at agreed locations.

Pattern and history of fluid failure Progression.

Wing temperature distributions.

Amount of fluid applied in each test run, and fluid temperature

Meteorological conditions.

5.5.14 'Clean' Fluid Thickness Measurements

In the event that there is no precipitation at the time of the dry run, or during full scale tests, advantage shall be taken to make measurements of fluid thickness distributions on the wings. These measurements shall be repeated for a number of fluid applications to assess uniformity of fluid application.

5.5.15 Pilot Observations

Contact airlines and arrange for pilots to be present during tests to observe fluid failure and failure progression. Record pilot observations for later correlation with aircraft external observations.

5.5.16 Remote sensor records

Record the progression of fluid failure on the wing using RVSI and/or SPAR remote contamination detection sensors.

5.5.17 Videotape Records

Make videotape records of tests. Provide professional video tape coverage for at least two overnight test sessions.

5.5.18 Return of equipment

Return any equipment obtained from airlines for use during the tests to its original condition at the end of the test program.

5.5.19 Assembly and analysis of results

Assemble and analyze all results.

5.6 Fluids Physical Properties Measurements

In concert with the testing of fluids on flat plates undertaken in task 5.2 and the testing of fluids on aircraft undertaken in task 5.5, an independent researcher will conduct tests to determine the physical properties of the pertinent fluids.

Participate in a meeting with the researcher, to be called by TDC, to clarify roles and responsibilities and to establish priorities.

One of the flat plates to be used for flat plate measurements of fluid behaviour in all tests shall be fitted with a C/FIMS sensor. Make this plate available to the independent researcher for dedicated tests upon request. Make additional plates available for dedicated tests as requested by TDC.

5.7 Coordination with NRC

TDC will arrange with NRC to make the CEF cold chamber facility available for controlled environment testing as given in "Detailed statement of work". Co-ordinate with NRC for conduct of tests.

5.8 Presentations of test program results

5.8.1 Preliminary Findings

Prepare and present preliminary findings of test programs involving field tests with aircraft to representatives of Transport Canada and the Airlines involved at end of the test season, but no later than May 30 1997.

5.8.2 SAE G-12 Committee

Prepare and present, in conjunction with Transport Canada personnel, winter test program results at the SAE G-12 Committee meeting in Pittsburgh in June 1997.

5.8.3 Test Program Data

All data from tests shall be assembled in electronic format; a backup of all data files will be stored on a dedicated PC and presented to TDC. The data files will be updated on an ongoing basis throughout the test period. Graphic presentation material shall be supplied to facilitate data display.

5.9 Reporting

Reporting shall be in accordance with section 10 "Reporting", below. Separate final reports shall be issued for each area of activity consistent with the project objectives.

6. ROLE OF OTHER PARTIES

Agreements as and when needed will be made by Transport Canada with the following airlines: Air Canada, American Airlines, Comair, Canadian Airlines International Ltd., and Canadian Regional Airlines Ltd. to provide aircraft, equipment and facilities for conduct of tests as outlined in the 'Detailed statement of work'. Direct contact with appropriate personnel of the airlines is encouraged, however TDC shall be advised of all such contacts.

APPENDIX B

PROCEDURES FOR CONDUCTING TESTS ON JET AIRCRAFT

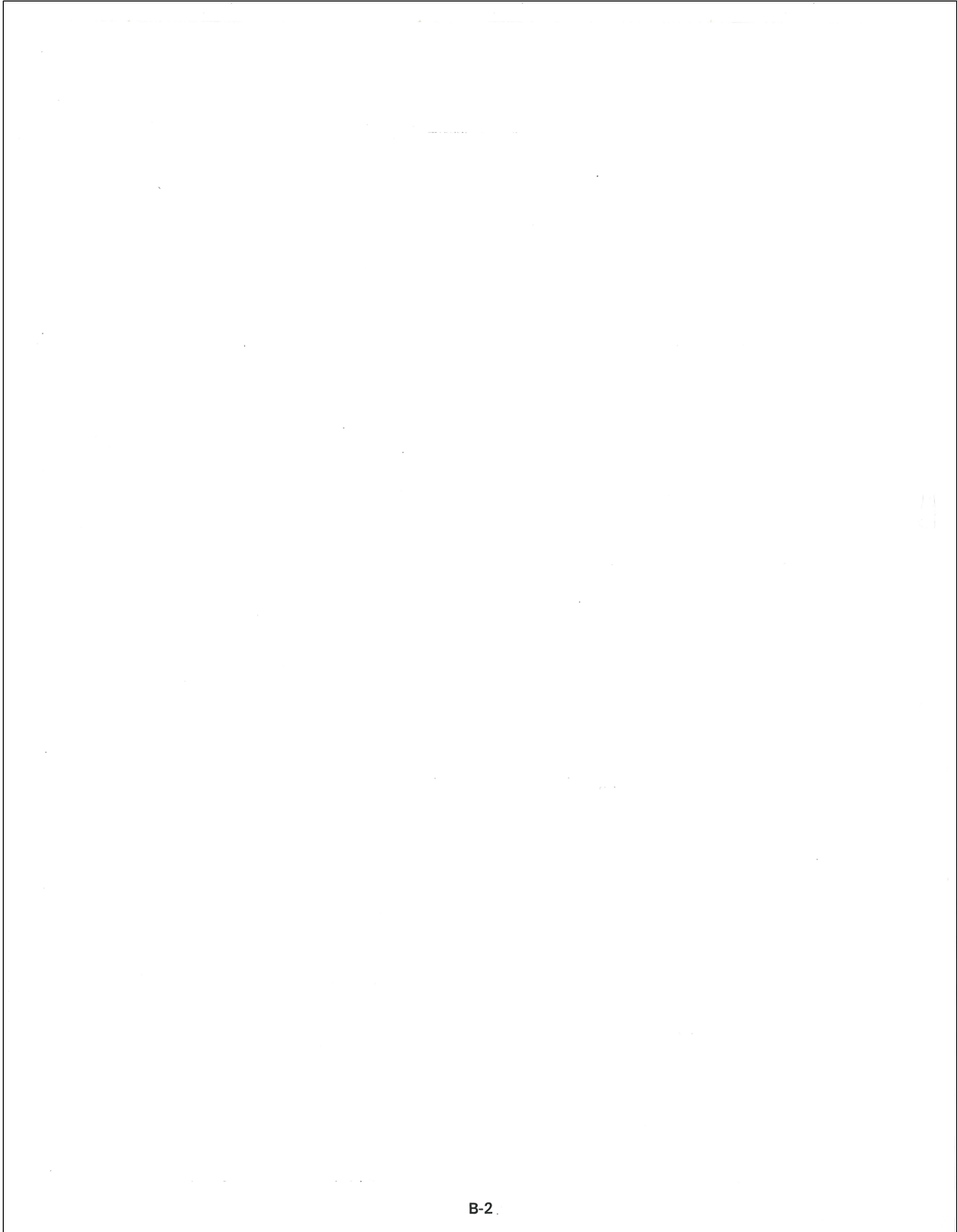
CM1338.001

**EXPERIMENTAL PROGRAM
FOR SIMULTANEOUS AIRCRAFT VS PLATE TESTING
1996 - 1997**

APS Aviation Inc.

January 20, 1997
Version 3.5

B-1



B-2

EXPERIMENTAL PROGRAM - Simultaneous Aircraft vs Plate Testing

**EXPERIMENTAL PROGRAM
FOR SIMULTANEOUS AIRCRAFT VS PLATE TESTING
1996 - 1997**

This document provides the detailed procedures and equipment required for the conduct of simultaneous aircraft vs plate testing for the 1996/97 winter season. The document is a revision to the documents used for testing during the 1994/95 and 1995/96 winters.

1. PURPOSE OF TESTS

Background: Fluid holdover time tables used by pilots after de/anti-icing have been developed and substantiated based upon tests conducted by APS on standard flat plates inclined at 10°.

Primary Objectives:

1. Correlation of fluid performance on flat plates with fluid performance on aircraft. Are the holdover time tables applicable to the aircraft being tested?
2. Location of Point of first fluid failure. Where should the focus of visual inspection be?
Is the point of first failure consistent, regardless of wind direction?
3. Distribution of (levels of) contamination at time of first failure. Would a sensor at a specific location predict fluid failure (wherever it might occur)?
4. Location, distribution and profile at first failure.

Secondary Objectives:

1. Determination of *clean* fluid thickness distributions on wings.
2. Determination of *contaminated* fluid thickness distributions on wings.

Applications: To determine whether an array of point detection fluid integrity sensors, with an appropriate algorithm, can provide a reliable warning of an *unsafe to take-off* condition.

To determine where pilots should concentrate visual inspection at the end of the holdover time, and to determine the extent of fluid failure during 15-minute periods following first failure.

EXPERIMENTAL PROGRAM - Simultaneous Aircraft vs Plate Testing

2. AIRCRAFT/AIRLINE, TEST LOCALE, AND TEST SET-UP

Airline: American/Delta/Canadian/Canadian Regional/Inter-Canadian

Aircraft: Fokker F-100/Canadair RJ/B-737/ATR-42/DHC-8

Locale: Primarily Dorval Airport, possibly Toronto or Ottawa

Test Set-up:

- Aircraft out-of-service, over-night tests based on predicted precipitation - 24 hours notice
- Aircraft cabin accessible for simulated pilot inspection of critical surfaces.
- Aircraft parked at pre-determined orientation prior to start of test. Re-orientation required during each test.
- At completion of tests (prior to first airline use in the morning), aircraft to be de-iced and returned to *service* condition.

Test Period (nominal): 15 December 1996 - 15 April 1997
except period December 23, 1996 - January 2, 1997. A total of 10 one-night test sessions is anticipated, plus a *dry* run.

3. TEST PROGRAM

Attachment I provides a list of tests to be conducted on a typical evening. Aircraft will be initially positioned, and re-positioned following individual tests, and towed away at the end of each one-night test session. Up to ten one-night overnight test sessions are planned. A matrix of tests is anticipated based on: head-wind, cross-wind, and tail-wind orientations. De-icing (Type I), and De-icing/Anti-icing (Type IV) fluids available by the airline will be applied to the wing. Tests will be conducted during snow, freezing drizzle and freezing rain precipitation.

4. EQUIPMENT

Test equipment required for the tests is provided in Attachment II. Details and specifications for some of the equipment is provided in the experimental plan developed for Dorval's standard flat plate testing "Experimental Program for Dorval Natural Precipitation Testing 1996/97" (*FPTP*).

EXPERIMENTAL PROGRAM - Simultaneous Aircraft vs Plate Testing

5. PERSONNEL

Up to fourteen personnel are required to conduct tests for each occasion. A description of the responsibilities and duties of each of the personnel is provided in Attachment III. Depending upon the weather forecast at the site, the number of personnel may be reduced or increased. Figure 1 shows a schematic of the positioning of the test personnel. Ground support personnel from the airlines will be available to apply fluids, position the aircraft and facilitate the inspection of the critical aircraft surfaces.

6. SUMMARY OF PROCEDURE AND MEASUREMENTS

The test procedure is included in Attachment IV. The following observations are anticipated: Trained observer assessment of wing condition from outside the aircraft. Fluid condition histories at selected points on the wings during the tests, with emphasis on condition of fluid at anticipated sensor locations at time of first fluid failure (wherever that might be).

Fluid thickness histories: advantage will be taken of occasions when precipitation stops during the night to take thickness measurements on uncontaminated fluids.

Video-record coverage of the tests will be made.

7. DATA FORMS

The data forms are listed below:

●	Figure 3	General Data Form (every test)	T7
●	Figure 3a	General Data Form (once per session)	T6
●	Figure 4	Aircraft Data Form	T2/T4/T8
●	Figure 5	Fluid Sampling Data Form	T10/T12
●	Figure 6	Fluid Thickness Data Form	-
●	Table 1	Holdover Time Data Form	T3
●	Table 2	Meteo Data Form	T1

8. ROLES OF PARTICIPATING AGENCIES

APS: To coordinate and conduct tests.
 TDC: Funding of program. Findings and reports will be made available to the aviation community.

Airlines: Provide aircraft, spray vehicles, personnel.
 Others: Union Carbide will provide fluid samples; Optima will collect fluid samples to support APS.

EXPERIMENTAL PROGRAM - Simultaneous Aircraft vs Plate Testing

9. PROPOSED NOTICE PROCEDURE

Notice given

I) Potential for testing	24 to 48 hrs before
ii) Day of testing - Monitoring throughout day	By 4:00 pm
iii) Day of testing - Confirm or cancel (if possible)	By 8:00 pm
iv) Proceed to Gate B2/De-icing Pad	10:00 pm
v) Preparation/Briefing	10 to 11:00 pm

Listing of potential participants

- | | |
|---|--|
| <ul style="list-style-type: none"> ● AlliedSignal ● UCAR ● Optima ● TDC ● ATAC ● Sypher Mueller | <ul style="list-style-type: none"> ● UQAC ● Airline contacts ● ADM, re: snow removal ● Air Traffic Control ● Canadair ● Hudson General |
|---|--|

10. EQUIPMENT AND SERVICES REQUESTED FROM AIRLINES

Airlines are requested to make available aircraft for Transport Canada to implement the above test program.

Aircraft to be initially positioned, re-positioned following individual tests, and towed away at end of each one-night test session.

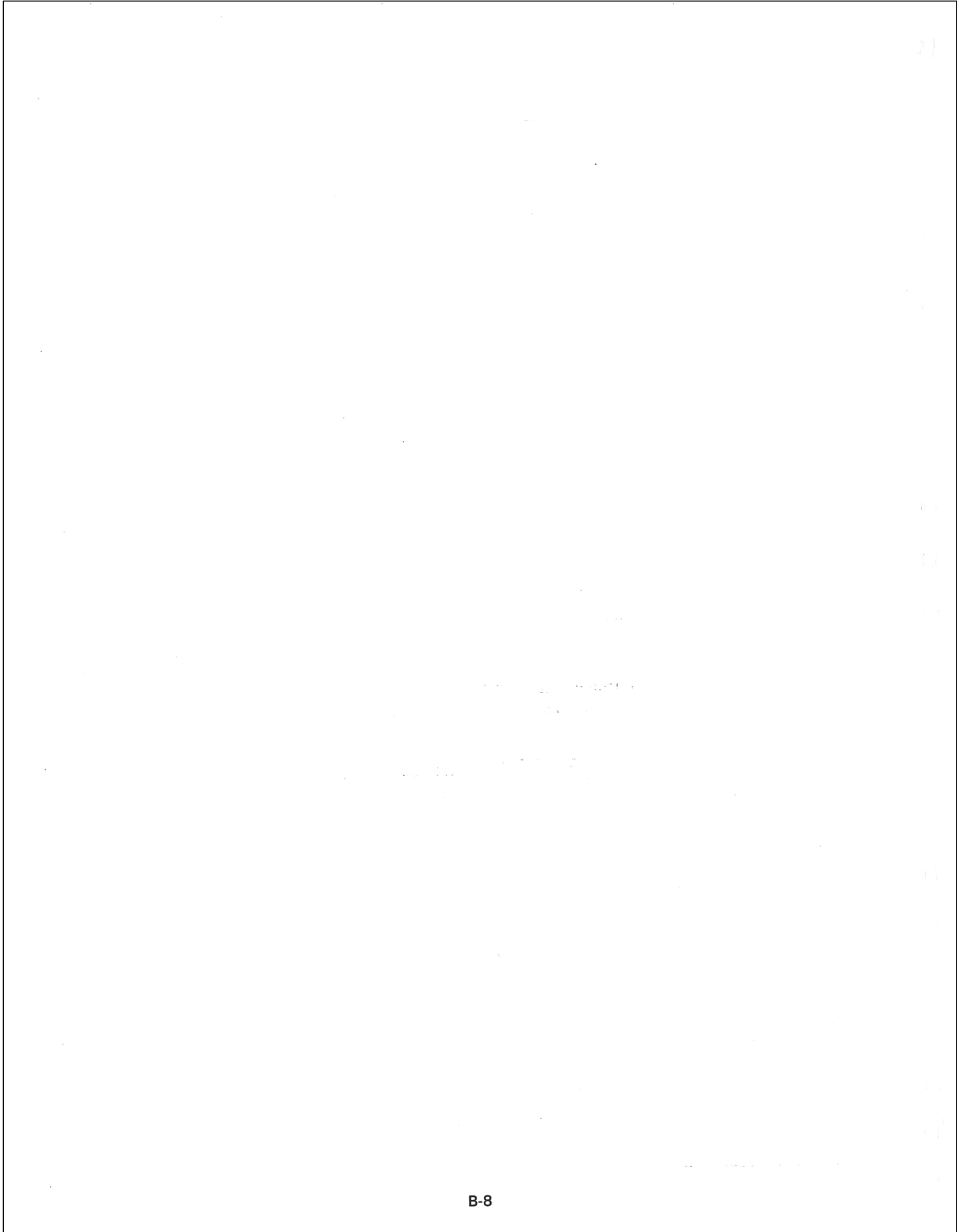
Airlines are requested to provide a de/anti-icing truck with crew for fluid application in accordance with the above program.

Direct cost of crew to be borne by contractor. Credits for fluids will be given to the airlines by the fluid manufacturer.

ATTACHMENT I
**TEST PLAN FOR
 SIMULTANEOUS AIRCRAFT vs PLATE TESTS AT YUL**

OCCASION	RUN #	FLUID ⁽¹⁾ TYPE	A/C ORIENTATION
1	1	I / IV	Tail
1	2	I	Tail
1	3	I	Tail
1	4	I / IV	Cross
1	5	I / IV	Cross
1	6	I	Cross
1	7	I	Cross
1	8	I / IV	Head
1	9	I	Head
1	10	I	Head

⁽¹⁾ Selection of fluid is dependent upon precipitation rate.



B-8

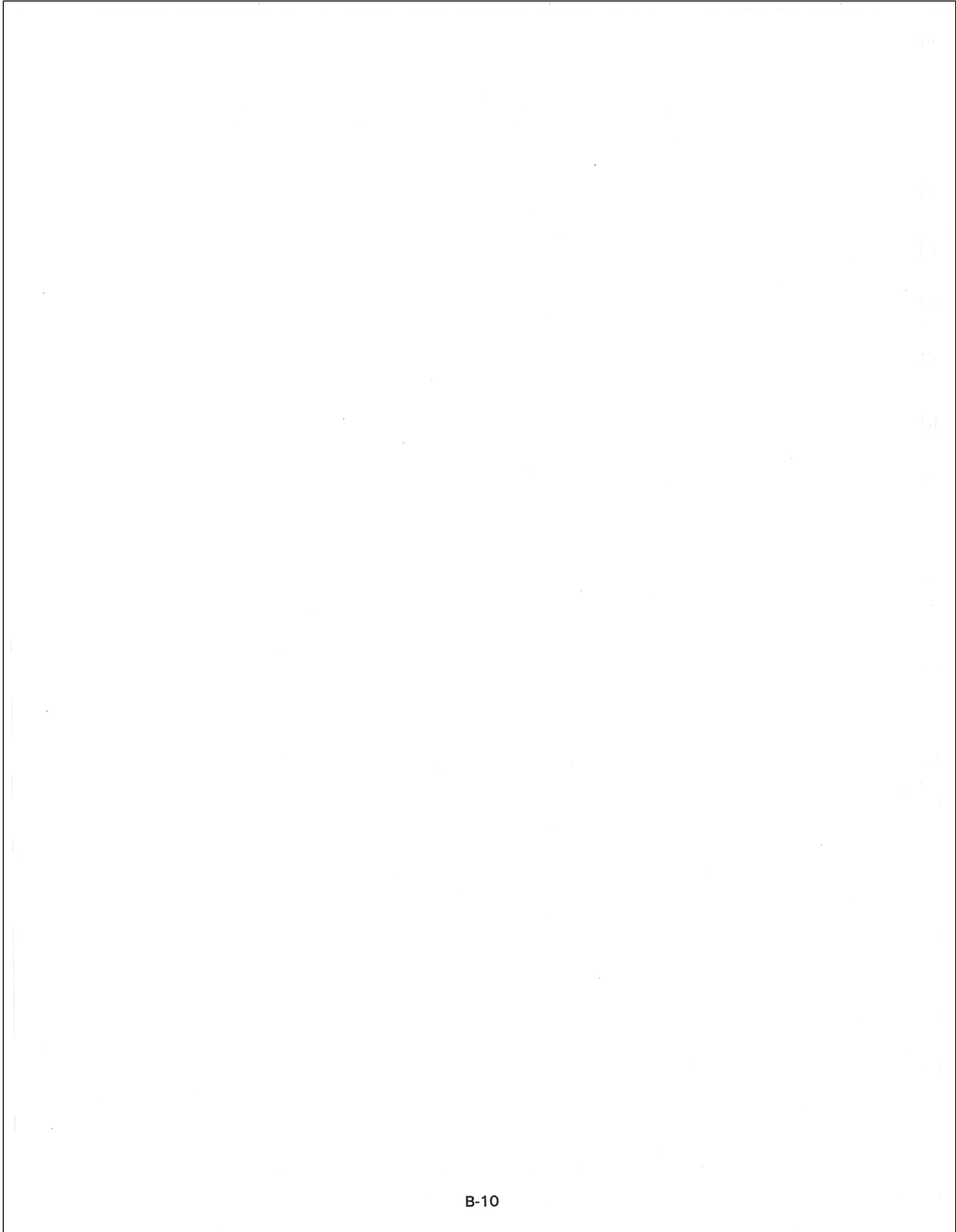
ATTACHMENT II
SIMULTANEOUS AIRCRAFT vs PLATE TESTS
TEST EQUIPMENT CHECKLIST

TASK	Resp.	Status	Pad Location
Logistics for Every Test			
Passes x 2 / Escort x 2			
Rent Van / Rent Generators			
Call Personnel			
Advise Airlines (Personnel, A/C Orientation, Equip)			
Monitor Forecast			
Call potential participants			
Test Equipment			
<i>Stand X 2 Blue detached ones (with plates)</i>			W, E
Tape Recorder with Mic.(voice) x 2			W
Weigh Scale x 2			W
Video Cameras X 3 + 15 batteries + 2 chargers			T
Thickness Gauges x 4 + extensions + wipers			W
Data Forms for plates and general			W
Aircraft Wing Forms			W
<i>XL 54 Fluid for plates (20L)</i>			W, E
<i>Ultra+ Fluid for plates x4 red containers</i>			W, E
<i>Plate Pans X 4</i>			W, E
Compass x 1			W
Video cassettes / films			W
Clipboards			W
Space pens and pencils			W
Paper Towels			W
Rubber squeegees x 2			W, E
Plastic Refills for Fluids and funnels			W, E
<i>Electrical Extension Chords</i>			W, E ?
<i>Lighting x 6 single black & 3 double yellow poles???</i>			W, E
Tools			W
Stop watches			W
<i>Pylons</i>			W, E
Laser Pointers x 3			W
Storage bins for small equipment			W
Temperature Probe x 2			W
VHF radios			W
Flash lights x 4			W
Protective clothing			W
Refractometer + brixometer			W
Tie wraps			W
Tags (Labels) for Fluid designation on stand			W
Scrapers x 2			W
Whistle x 2			W
<i>Rolling Stairs x 6</i>			W, E
Sampling tools x 12 (Putty knives)			W
Sampling containers			W
Tape measure x 4 (2 small, 2 large)			W
Generators			W
<i>Mast lights?</i>			W
Duct Tape			W
Test procedure x 10			W
Photo Camera			O
<i>Step ladders (platforms) x 4 (2 x 6', 2 x 4')</i>			W
Fire extinguisher for trailer			W
Fuel for generator			W
Marker for wing			W
Space heater (Parabolic)			W
Non-slip step-ladder for truck			W
Solvent for wing			W
OTHER TEST EQUIPMENT (1)			
<i>XL 54 Fluids for wings (UCAR)</i>			
<i>Ultra+ Fluids for wings (UCAR)</i>			
<i>Spray vehicle for XL54 x1 (A/L)</i>			
<i>Spray vehicle for Ultra+ x1 (A/L)</i>			
<i>Test Aircraft (A/L)</i>			
<i>Storage Facilities</i>			
<i>Fluid Collection Facilities</i>			
<i>Electrical Power (A/L)</i>			
<i>Airline Personnel</i>			

NB: Items in italics must be moved to the pad for each session.
(1) To be provided by others

E = East
W = West
T = Test Site
O = Office

File:g:\ms1338\procedur\full_scl\CHKLS_AC.XLS
Printed:15/01/97



B-10

 ATTACHMENT III - RESPONSIBILITIES/DUTIES

 ATTACHMENT III
Simultaneous Aircraft vs Plate Tests
Responsibilities/Duties of Test Personnel

Refer to Figure 1 for position of equipment and personnel relative to the aircraft. Also refer to the test procedure (Attachment IV) for more detailed tester requirements.

- Video 1 (V1/V2) -
- One video operator per wing
 - Located on ground (Refer to FPTP)
 - Video aircraft test site
 - Ensure proper plate identification - zoom in and out
 - Picture to be steady and well lit
 - Knowledge of test procedures and end conditions
 - Video application of all fluids
 - Photograph plates and wings
 - Assist in deployment and return of lighting
 - To video wing before and after fluid application, to concentrate on fluid contamination and failure
 - Ensure proper identification of wing

- Meteo/Equipment Tester (T1) -
- Coordinate all equipment (inventory and operation)
 - Record meteo for both stands
 - Rotate and measure plate pan weights
 - Complete and sign data form (Table 2)
 - Measure wing temperatures at beginning of night
 - Ensure power cables and lighting is in place
 - Prepare plate pans
 - Ensure all clocks are synchronized (including video camera)

- Wing/Plate Coordinator (T7) -
- Ensure failure calls on plates and wings are consistent
 - Communicate initial failure to all involved
 - Assist wing and plate observers as required
 - Assist overall coordinator as required
 - Complete and sign general data form (Figure 3) for each test
 - Communicate with samplers T9/T11 critical sampling times
 - Manage and direct equipment deployment and return
 - Assist T1 in coordination of equipment
 - Communicate with cabin observer the spraying of wing A and wing B

ATTACHMENT III - RESPONSIBILITIES/DUTIES

Wing Observers

- (T2/T4)
- Located on ground (rolling stairs) or in cherry picker
 - Communicate with V2
 - Make observations of failures on starboard or port wing
 - Knowledgeable in procedures and calling end conditions

End Condition

- Tester (T3)
- Apply fluids to Stand
 - Located by Test Stand
 - Make observations and call end conditions on test stand
 - Knowledge of procedures for test stands

Overall coordinator

- (T6)
- Team Coordinator
 - Knowledge of test procedures and calling end conditions
 - Responsible for area and people
 - To aid any personnel
 - Coordinate actions of APS team and as required airline personnel
 - Responsible for weather condition observations and forecast, advise tester team
 - Call personnel to conduct tests
 - Ensure that there are no objects on the ground which may cause FOD at end of session.
 - Ensure test site is safe, functional and operational at all times
 - Supervise site personnel during the conduct of tests
 - Review data forms upon completion of test for completeness and correctness (sign)
 - Ensure aircraft positioned appropriately
 - Monitor weather forecasts during test period
 - Ensure fluids are available and verify fluids being used for test are correct
 - Ensure electronic data is being collected for all tests
 - Ensure proper documentation of tapes, diskettes, cassettes
 - Verify test procedure is correct (eg. stand into wind)
 - Ensure all materials are available (pens, paper, batteries, etc.)
 - Ensure all equipment is on
 - Ensure aircraft is not damaged
 - Complete general data form at beginning of night

Sampler

- (T9/T11)
- Knowledge of sampling procedure
 - Collect samples of fluids at predetermined wing - locations and times
 - Prepare sampling containers in advance
 - Prepare self-contained sampling kit in advance
 - Assist in deploying and returning equipment

CM1338\procedur\full_scl\simair3.5
Version 3.5
August 18, 1997

ATTACHMENT III - RESPONSIBILITIES/DUTIES

- Identify sampling positions on aircraft wing
- Map out aircraft with pylons and plan view of aircraft
- Remove marking from wing at end of night with solvent

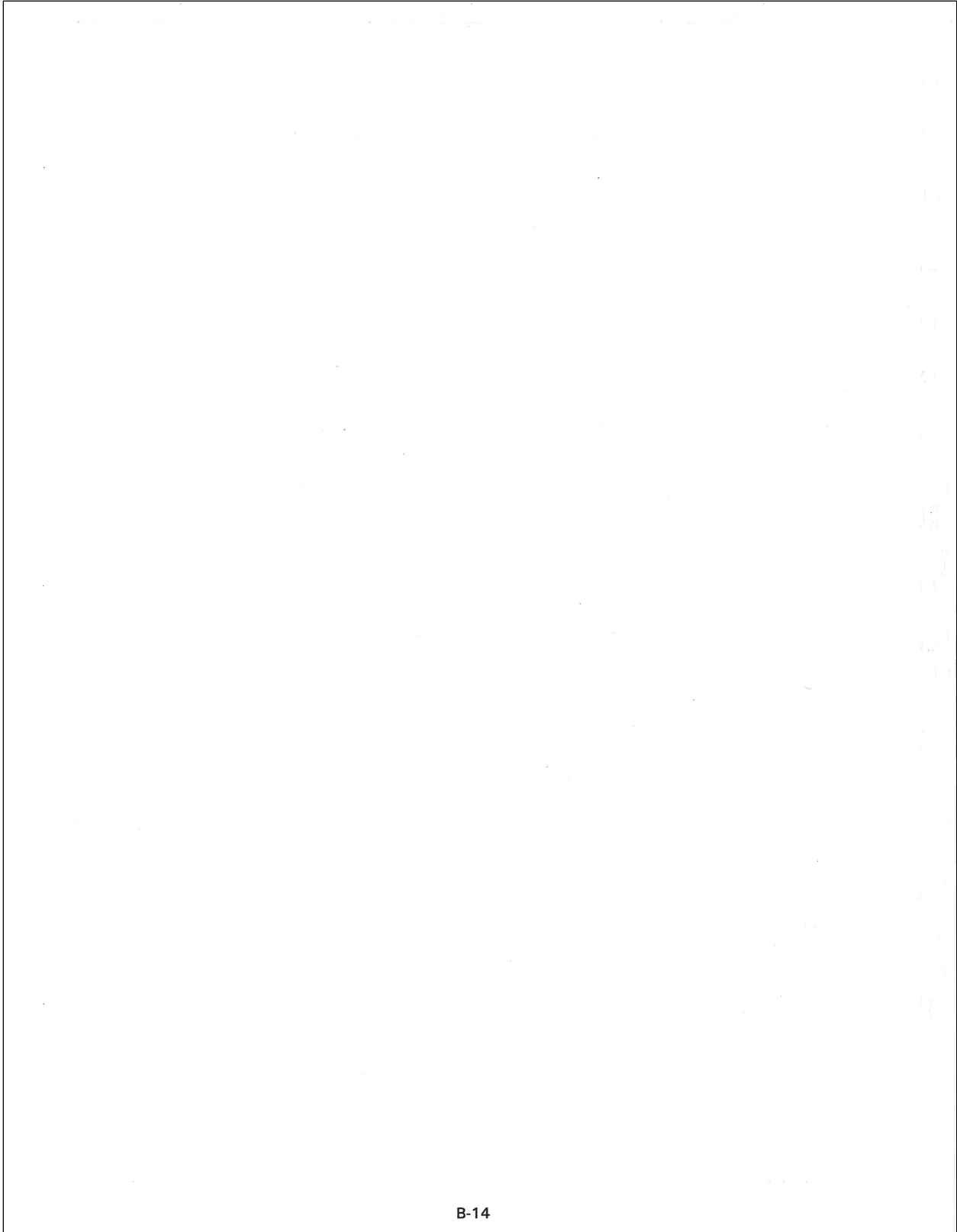
Sampler/Data Logging

T10/T12

- Prepare all data forms in advance
- Prepare and identify all media in advance
- Ensure all data forms and media is returned after every test
- Assist T9/T11 in collection of samples
- Provide all data forms to overall coordinator (T6) for signature
- Complete sampling data form and sign
- Knowledge of sampling procedure
- Assist in identifying sampling positions on wing
- Assist in deploying and returning equipment

Optima Sampler

- One or two additional persons from Optima to collect samples.



B-14

ATTACHMENT IV - TEST PROCEDURE

**ATTACHMENT IV
TEST PROCEDURE****1. Training and Safety**

Training for this experiment will consist of a dry-run in which team members are assembled and duties are assigned to each member. This will allow the team to conduct an experiment in which team members will coordinate their activities to prepare for a systematic and comprehensive execution of a given experimental run and try to determine the logistics of an actual experiment. The dry run will familiarize all test members with the equipment and provide the participating airline with an understanding of the procedure. This procedure will inevitably be streamlined during field testing. Most team members should be familiar with salient aspects of flat-plate testing. They should possess the ability to identify fluid failures, and call end conditions.

Attachment VI refers to Safety Awareness Issues for these tests. Ensure that these are observed and understood.

2. Pre-Test Set-Up

Figure 1 should be consulted in reference to the responsibilities. Also refer to Attachment VII.

1. Arrange favourable aircraft orientation (**leading edge, cross-wind or trailing edge into the wind**) and place pylons below wings to delineate sections.
2. Set-up power cords and generator.
3. Position stairs and lights.
4. Ensure temperature probes and weigh scale are functional.
5. Position flat plate test stand into the wind as per the *FPTP*. Note that this orientation may be different than that of the aircraft.
6. Position pre-filled test fluid containers, squeegees, and scrapers accordingly. (Type I fluids are stored inside at 20°C; Type IV fluids are applied at ambient temperature).
7. Check cameras and recording devices for proper function.
8. Ensure proper illumination of test areas.
9. Establish communication between team members and coordinator.
10. Camera and test personnel ensure ability to identify laser light signature.
11. Synchronize all timepieces including video cameras.
12. Ensure airline personnel are aware and knowledgeable of test procedures.
13. Prepare data forms in advance of all tests.
14. Prepare media (video) and sample equipment in advance of all tests.

ATTACHMENT IV - TEST PROCEDURE

3. Initialization of Fluid Test

1. Ensure all aircraft de/anti-icing systems are off.
2. Measure and record fuel load in wing to be tested.
3. Measure wing skin temperature at predetermined locations before fluid application (see Figure 3a).
4. Record all necessary data from fluid delivery vehicle (cherry picker). (Temperature, nozzle-type, fluid type, dilution of fluid, etc.).
5. Record all general measurements and general information in the data forms. Attach clips with fluid name and type to stand.
6. Ensure all fluids are prepared to the appropriate concentrations.
7. Attach boards form wing designation for video, for outside and for cabin.

4. Execution of Fluid Test

1. **Type I Fluid Application (Figure 2a)**
 - 1.1 Apply Type I fluid (XL 54) with de-icing vehicle to wing
 - 1.2 Simultaneously apply Type I (XL 54) to plates V and Y from containers
2. **Type IV Fluid Application (Figure 2b)**
 - 2.1 Apply Type I and then Type IV to wing with de-icing vehicle
 - 2.2 Apply Type IV to plate W and Z when application of Type IV to the wing begin
3. Plate/wing coordinator sounds whistle once to confirm the beginning of test (after fluid application). Fluid Samplers will be required to measure film thickness on wing.
4. Plate/wing coordinator sounds whistle twice to confirm the initial failure on the wing. Fluid Samplers will be required to take samples of Type I fluid on the wing.
5. Put two plate pans on test stand and note time and initial weights (refer to *FPTP*). Continue measuring every 5 minutes until end of test. Re-measure when second wing is started.
6. Continue testing until the end conditions are called for both flat plates.
7. Collect fluid samples as per the test procedure described in Attachment V.

5. Holdover Time (end condition) Testing

Holdover time testing will consist of: A) Video recording of all procedures and fluid failures; and B) Visual monitoring and manual recording of failure data.

A. Video Recording (V1/V2)

Camera recordings are to be systematic so that subsequent viewing of documented tests allow for the visual identification of failing sections of the wing surface with respect to the aircraft itself.

1. Record the complete fluid application from a distance.
2. Record the conditions of the flat plate set-up and the wing at time = 0.
3. (I) For Type I fluids, record conditions of wing and flat plates every 2 minutes.

 ATTACHMENT IV - TEST PROCEDURE

- (ii) For Type IV fluids, record conditions of wing and test plates every 5 minutes.
- 4. Once the first failure on the wing or on the one inch line is called, monitor (record) continuously until the end of the test.
- 5. Record the "important events" as described in the form (Figure 4)
- 6. Record condition of the wing and representative surface continuously from the aircraft cabin.

 B. Visual Recording

- 1. For the plates, refer to *FPTP* for determination of the end condition.
- 2. For the wing, three (3) ways to record visual observations have been devised.
 - (I) Manual recording of failure contours on preprinted data form (Figure 4). This is to be performed by person making the observations, and/or
 - (ii) Observer may talk to a voice recorder, and/or
 - (iii) Observer may talk directly to the video camera microphone.

In any case, the methods would utilize the Wing Section Data Form (Figure 4), and these are complementary to the video recording.

- 3. The pattern of failures should be drawn on the data form **5 minutes after first failure on the wing.**
- 4. When the first flat plate failure is reported at the 5th crosshair ($\frac{1}{3}$ of plate), the visual data recorder must acquire contours every 2 to 5 minutes, thereafter. Time increment is dependent upon weather. Process is continued until all flat plates have failed according to the end condition defined in the *FPTP*.
- 5. If wing fails before first flat plate fails, continue data collection for wing via contour drawing and/or voice communication until all flat plates fail wing/plate.
- 6. Wing/plate coordinator must confirm initial end condition calls on flat plate tests. Once the first flat plate fails at the six inch line ($\frac{1}{3}$ of plate), the coordinator is notified and makes inspection of the wing contour drawing to confirm the accuracy of the wing data and instructs video camera operator to make a record of the area. The area should be located using a laser pointer. If the wing start to fail first, the coordinator must confirm this and simultaneously note areas of failure on the flat plates using the laser pointer.
- 7. Measure wing skin temperatures at the start of the evening. If the wing is cold-soaked, then continue monitoring the temperatures.

ATTACHMENT IV - TEST PROCEDURE**6. End condition**

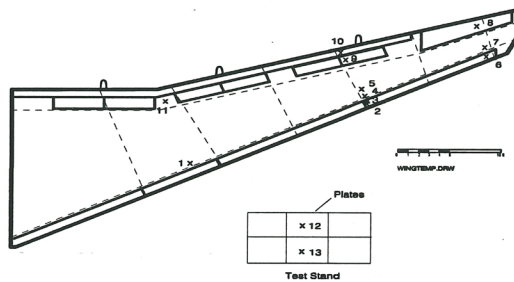
Refer to the *FPTP* for this definition.

7. End of test

Plate/wing coordinator sounds whistle to confirm the full failure of wing (end of run). This occurs when all plates have reached the end condition (under heavy snow conditions, continue testing until nine crosshairs have failed) and when a substantial part of the aircraft wings leading/trailing edge has reached the end condition. Most or all of the "important events" in the aircraft wing data from (Figure 4) must be completed by. Ensure all data collection is completed including plate pan measurements.

ATTACHMENT V
TEST PROCEDURE FOR SAMPLING OF FLUIDS

- 1) Locate sampling points using a black marker. Each wing has sampling locations as shown in the schematic. Each plate has one sampling position.
- 2) Take samples at time increments given below.
 Take a sample (> 10 drops) at all locations on that wing.
 Take a sample over the 5th failed crosshair on each plate. Follow the collection sequence as indicated below.
 Stagger collection of samples. Measure film thickness on points 3, 4 and 10 at the same time that samples are taken, and at the start of the test when the fluid is applied.
- 3) Cover container between each sampling. Record sampling time.
- 4) Leave samples inside, allowing them to warm up. Identify each container with run # and measure brix values on following day with MISCO 10431 Refractometer
- 5) Collect samples of non-contaminated fluid (Type I and Type IV) from containers and truck.
- 6) Remove markings from aircraft with solvent.



SEQUENCE SAMPLE POSITIONS FOR EACH TEST

- 1 - 1/4 of wing span - MID 6" from LE joint
- 2 - 1/2 of wing span - LE nose
- 3 - 1/2 of wing span - LE half way between joint and nose*
- 4 - 1/2 of wing span - MID 6" from LE joint*
- 5 - 1/2 of wing span - MID as far as reach with stick
- 6 - 3/4 of wing span - LE half way between joint and nose
- 7 - 3/4 of wing span - MID 6" from LE joint
- 8 - 3/4 of wing span - TE 6" below joint
- 9 - 1/2 of wing span - MID 12" from TE joint
- 10 - 1/2 of wing span - TE 6" below joint*
- 11 - 1/4 of wing span - MID 6" from TE joint
- 12 - Top plate of stand - 6" line on 5th crosshair
- 13 - Bottom plate of stand - 6" line on 5th crosshair

MEASUREMENT TIME⁽¹⁾

- Every 15 minutes for Type IV; and after 1st failure and end of test for Type I.
- Every 15 minutes for Type IV; and after 1st failure and end of test for Type I.
- Every 15 minutes for Type IV; and after 1st failure and end of test for Type I.
- Every 15 minutes for Type IV; and after 1st failure and end of test for Type I.
- Every 15 minutes for Type IV; and after 1st failure and end of test for Type I.
- Every 15 minutes for Type IV; and after 1st failure and end of test for Type I.
- Every 15 minutes for Type IV; and after 1st failure and end of test for Type I.
- Every 15 minutes for Type IV; and after 1st failure and end of test for Type I.
- Every 15 minutes for Type IV; and after 1st failure and end of test for Type I.
- Every 15 minutes for Type IV; and after 1st failure and end of test for Type I.
- Every 15 minutes for Type IV; and after 1st failure and end of test for Type I.
- Once when plate failed.
- Once when plate failed.

* For these points for Type I tests, collect samples immediately following the measurement for initial film thickness.

SAMPLES TAKEN ONCE IN THE EVENING

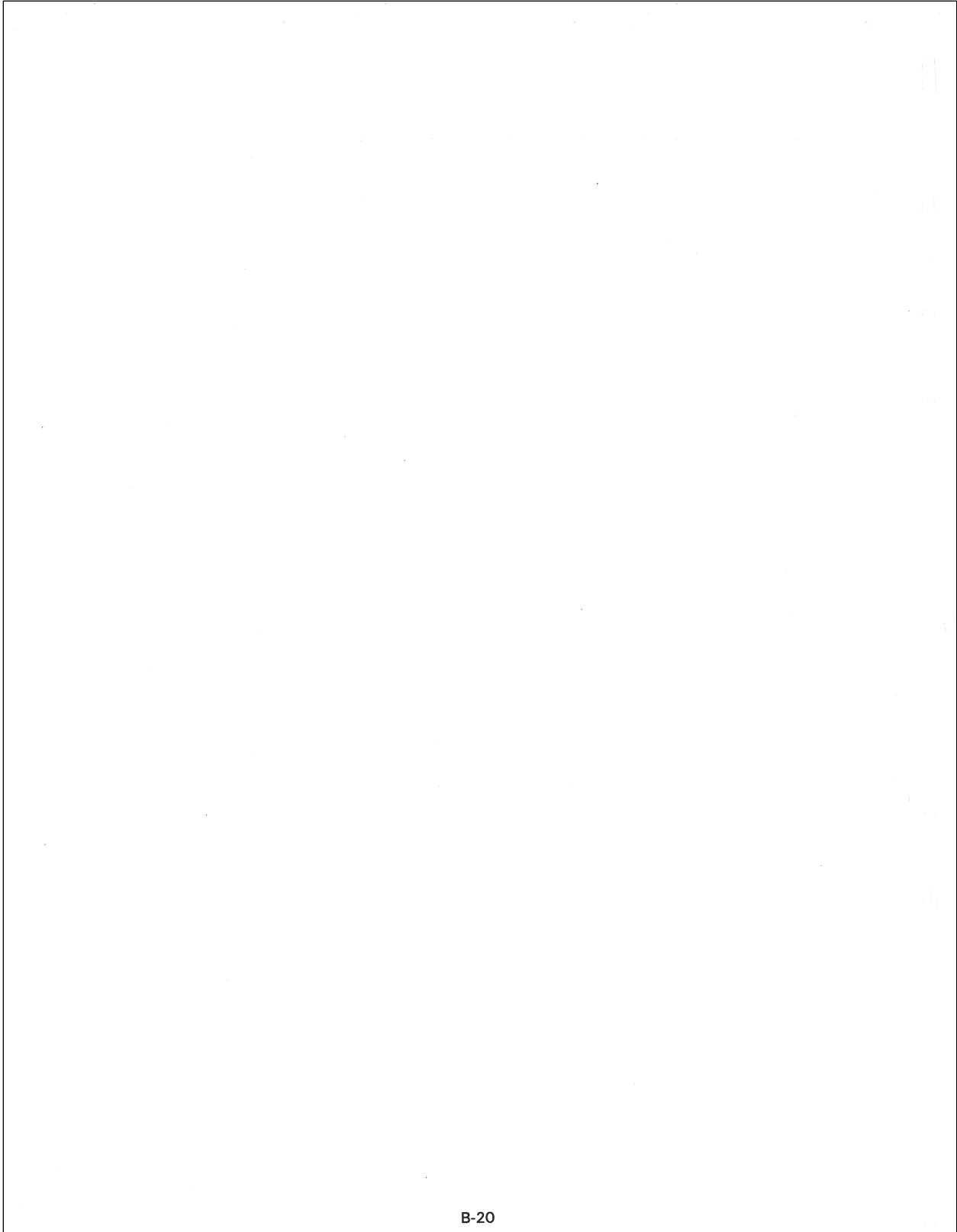
- S_{p1} - sample of Type I fluid from container.
- S_{p2} - sample of Type IV fluid from container.
- S_{t1} - sample of Type I fluid from truck
- S_{t2} - sample of Type IV fluid from truck

SENSORS LOCATIONS

- X₁ = 4.81⁽²⁾ meters, 2/3 of LE nose to joint.
- X₂ = 8.1⁽²⁾ meters, 2/3 of LE nose to joint.

⁽²⁾ Center of fuselage

g:\cm1338\procedur\full_scl\SF0RM-1.XLS
 At: Procedure
 Printed: 97-8-18

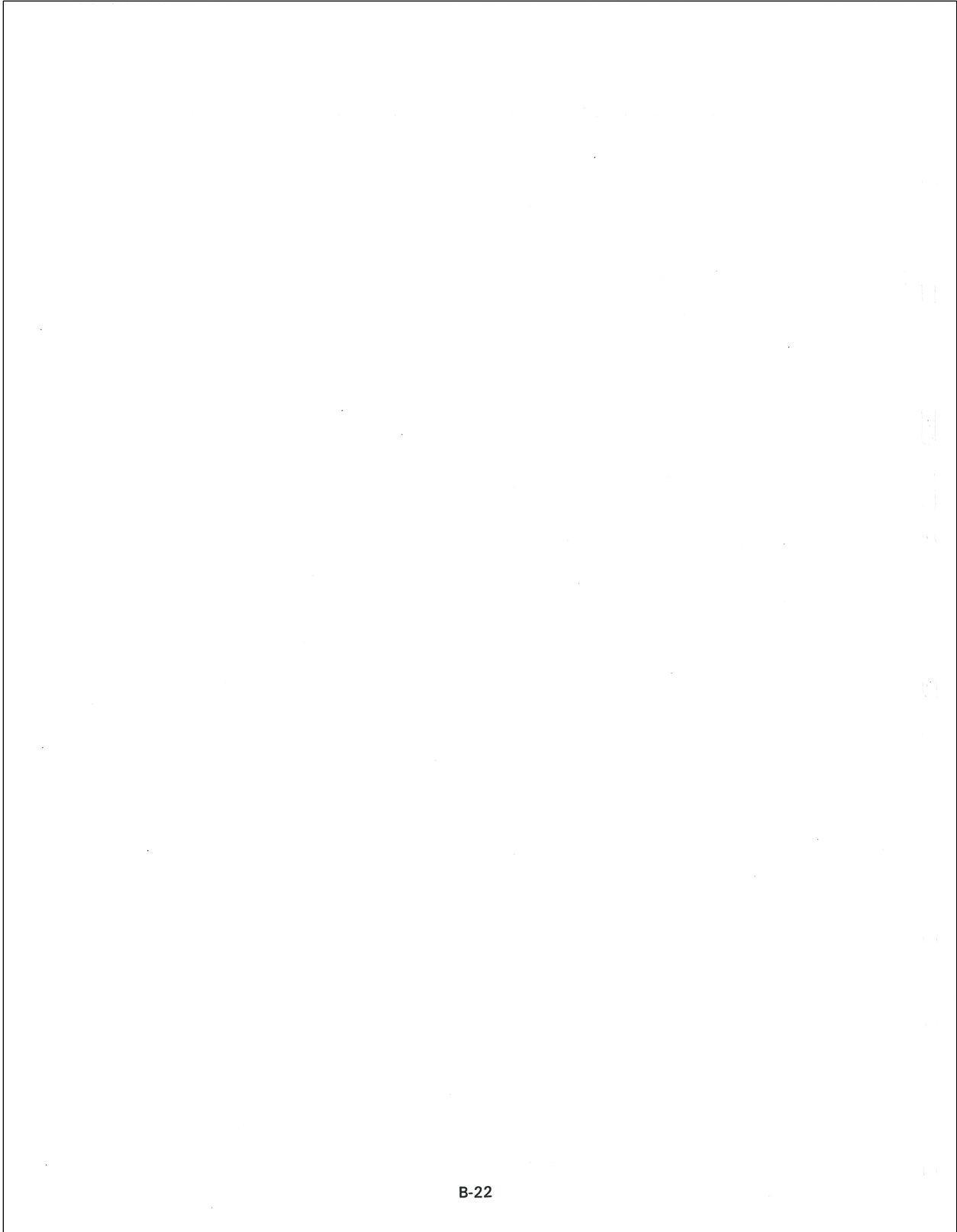


B-20

ATTACHMENT VI - SAFETY AWARENESS ISSUES

**ATTACHMENT VI
SAFETY AWARENESS ISSUES**

- 1) Review MSDS sheets for fluids at site
- 2) Protective clothing is available
- 3) Care should be taken when climbing rolling stairs due to slipperiness
- 4) When moving rolling stairs, ensure they do not touch aircraft
- 5) To take fluid samples or measure film thickness on the aircraft, ensure minimum pressure is applied to the wing
- 6) Entry into the aircraft cabin is not authorized, except for cabin observer (T8), video (V1), or overall coordinator (T6). For these people, booths are to be removed at entrance.
- 7) When aircraft is being sprayed with fluid, testers and observers should be positioned away in the hold area (see Figure 1).
- 8) First aid kit, water and fire extinguisher is available in trailer. Second first aid kit is available in mobile truck.
- 9) No smoking permitted on the ramp area and in trailer.
- 10) Care to be taken when moving generators and fuel for the generators.
- 11) Electrical cabling is needed to power lights - these will be positioned around the wing - do not trip over them. Do not roll stairs or other equipment over cables.
- 12) Do not walk by yourself in any area away from the pad or trailer - if required to do so, ask the coordinator T6 who will advise the security escort service.
- 13) Gasoline containers are needed to power the generators - ensure you know where these are.
- 14) Ensure lights and rolling stairs are stabilized to not damage the wing.
- 15) Ensure all objects and equipment are removed from de-icing pad at end of night.
- 16) Ensure all markings removed from wing.
- 17) Personnel with escort required passes must always be accompanied by persons with permanent passes.
- 18) Rolling stairs should always be positioned such that the stairs are into the wind. Small ladders should be laid down under windy conditions.



B-22

ATTACHMENT VII
SETUP AND MOVEMENT OF EQUIPMENT FROM TRAILER TO PAD

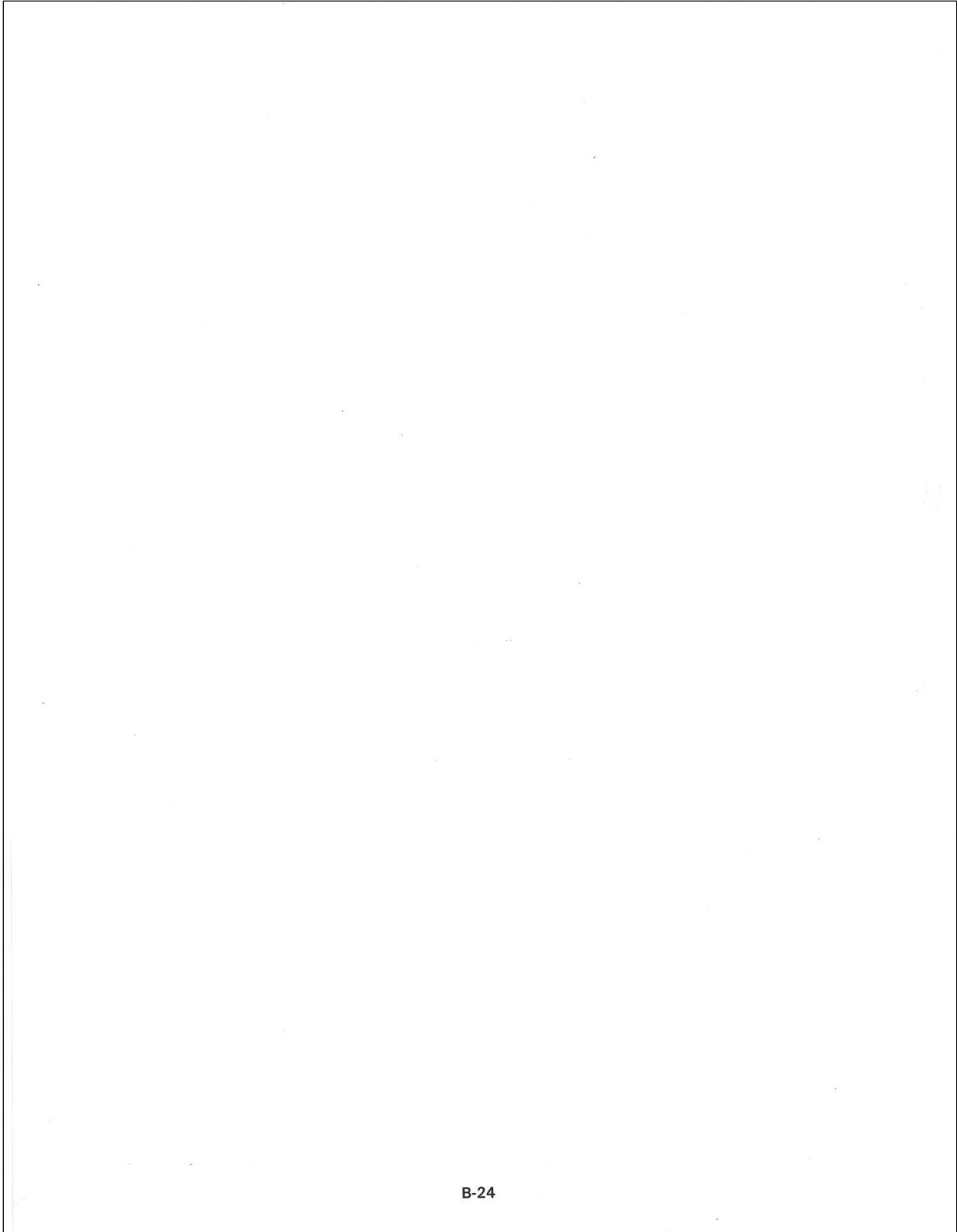
Task	Responsibility	10:00	10:30	11:00	11:30	00:00	00:30	01:00
Travel-Parking lot to Trailer	All	=====			* Flight arrives		* A/C on Pad	
Overall Briefing	T6		=====					
Assignments	T6			=====				
Issue Gear and Forms	T1, T4, T11			=====				
Organize Forms and Equipment	T7, All				=====			
Transport Equipment ⁽¹⁾ to Pad (4 trips)	T11, T9, T12, T1				=====			
Organize at Pad - Generators, Lights and Stairs	T2, T4, T10, T3				=====			
Set-up Van for test (plus personal equipment boxes)	T1, T2						=====	
SET-UP EQUIPMENT AT A/C							=====	
Set-up Generators and main Cables	T4, T10						=====	
Set-up Stairs, Cables and Lights	T4, V1, V2, T3						=====	
Set-up Pylons	T9, T11						=====	
Mark a/c	T9, T11, T10, T12						=====	
set-up Test stand, Lights and Fluids	T3						=====	
Pre Test briefing	T6							=====
Van (Transport)		=====			T2			
Cube					T1	=====		

B-23

(1) Equipment in Italics (Attachment II)

Note: Replacement of Equipment following test has same staff assignments

File:g:\cm1338\procedur\full_scl\STP_DRY.XLS

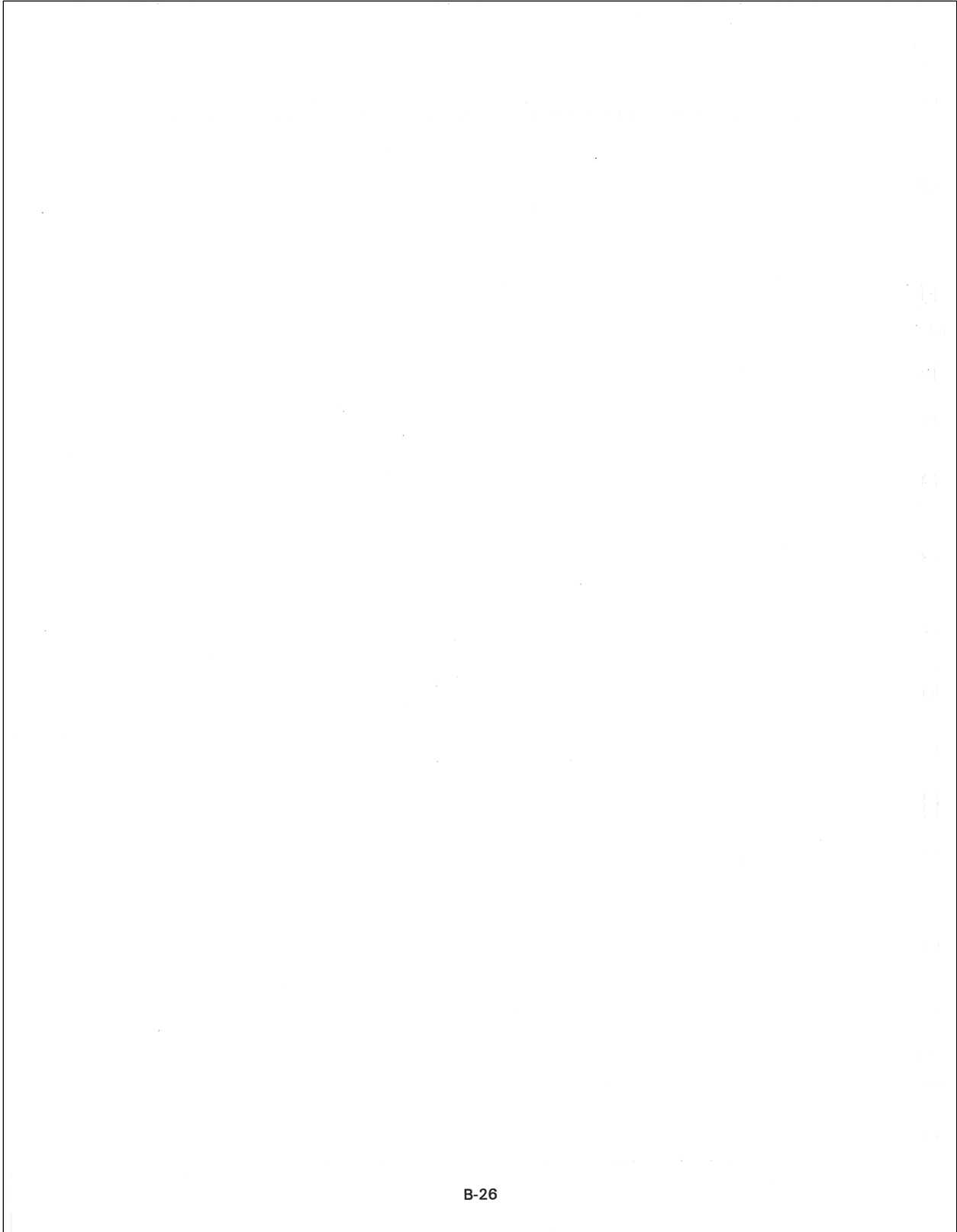


B-24

ATTACHMENT VIII -TEST PROCEDURE FOR MEASURING FLUID THICKNESS

ATTACHMENT VIII
TEST PROCEDURE FOR MEASURING FLUID THICKNESS

- 1) Fluid thicknesses will be measured during periods of no precipitation. This may be during test events when snow or rain fall has ceased, or during dry runs.
- 2) Locations where fluid thickness will be measured are at those locations selected for taking fluid samples during regular tests. Indicate measurement points using a black marker. (Ensure markings are removed at end of test, using solvent).
- 3) Fluid thickness will be measured four times; two initial fluid thickness measures taken immediately following fluid application, and subsequently at 10 minutes and at 20 minutes following fluid application.
- 4) Measure each location three times to increase reliability of results; record the thickness measure resulting from these consecutive trials. Ensure that thickness gauge placement for consecutive measures is slightly offset from previous placement to avoid influence of indents remaining in fluid film. Wipe gauge following each measure attempt.
- 5) Record data on the Fluid Thickness Data Form, Figure 6, in the format shown; measurement location, time, gauge reading.



B-26

ATTACHMENT IX -MOBILE EQUIPMENT FOR EACH TESTER

**ATTACHMENT IX
MOBILE EQUIPMENT FOR EACH TESTER**

- | | | |
|---------------------------|---|---|
| Video V1 | → | batteries |
| | → | video camera |
| | → | photo camera |
| | → | VHF radio |
| Video V2 | → | batteries |
| | → | video camera |
| | → | VHF radio |
| | → | Photo camera |
| Meteo/Equipment T1 | → | pens/pencils |
| | → | stop watch |
| | → | data form (Table 2) |
| | → | plate pans |
| | → | mobile equipment for truck (see Attachment X) |
| | → | skin temperature equipment |
| Wing/Plate Coordinator T7 | → | test procedure |
| | → | VHF radio |
| | → | stop watch |
| | → | laser pointer |
| | → | flash light |
| | → | data form (Figure 3) |
| | → | pens/pencils |
| | → | compass |
| Wing Observer T2/T4 | → | data form (Figure 4) |
| | → | laser pointer |
| | → | pens/pencils |
| | → | stop watch |
| | → | small tape measure |
| End Condition T3 | → | data form (Table 1) |
| | → | pens/pencils |
| | → | stop watch |
| | → | compass |

ATTACHMENT IX -MOBILE EQUIPMENT FOR EACH TESTER

- | | | |
|-----------------------------|---|----------------------------|
| Overall Coordinator T6 (x2) | → | test procedures |
| | → | VHF radio (x1) |
| | → | flash light |
| | → | pens/pencils |
| | → | stop watch |
| | → | tape recorder (x1) |
| | → | data form (Figure 3a) (x1) |
| | → | small tape measure |
| Sampler T9/T11 | → | putty knives or syringe |
| | → | sample containers |
| Sampler/Logger T10/T12 | → | stop watches |
| | → | data forms (Figure 5) |
| | → | pens/pencils |
| Mobile Marking Kit X 2 | → | flashlight |
| | → | tape measure - long |
| | → | marker |
| | → | ink remover solvent |
| | → | degreaser |
| | → | pencils |
| | → | tape measure - short |
| | → | aluminium tape |

ATTACHMENT X -MOBILE EQUIPMENT REQUIRED FOR TRUCK (VAN)

ATTACHMENT X
MOBILE EQUIPMENT REQUIRED FOR TRUCK (VAN)

Weigh scale x 2 (with battery backup)
Table and chair
Light and electrical extension cable
Heater dish
Sampling equipment
Wind protection booth
Step ladder (non-slip)
Plate pans
Skin temperature equipment

Mobile box with extra:

- pens and pencils
- data forms
- batteries
- paper towels
- other material?
- flash light
- thickness gauge
- test procedure
- first aid kit
- fire extinguisher

FIGURE 1
POSITION OF EQUIPMENT AND PERSONNEL

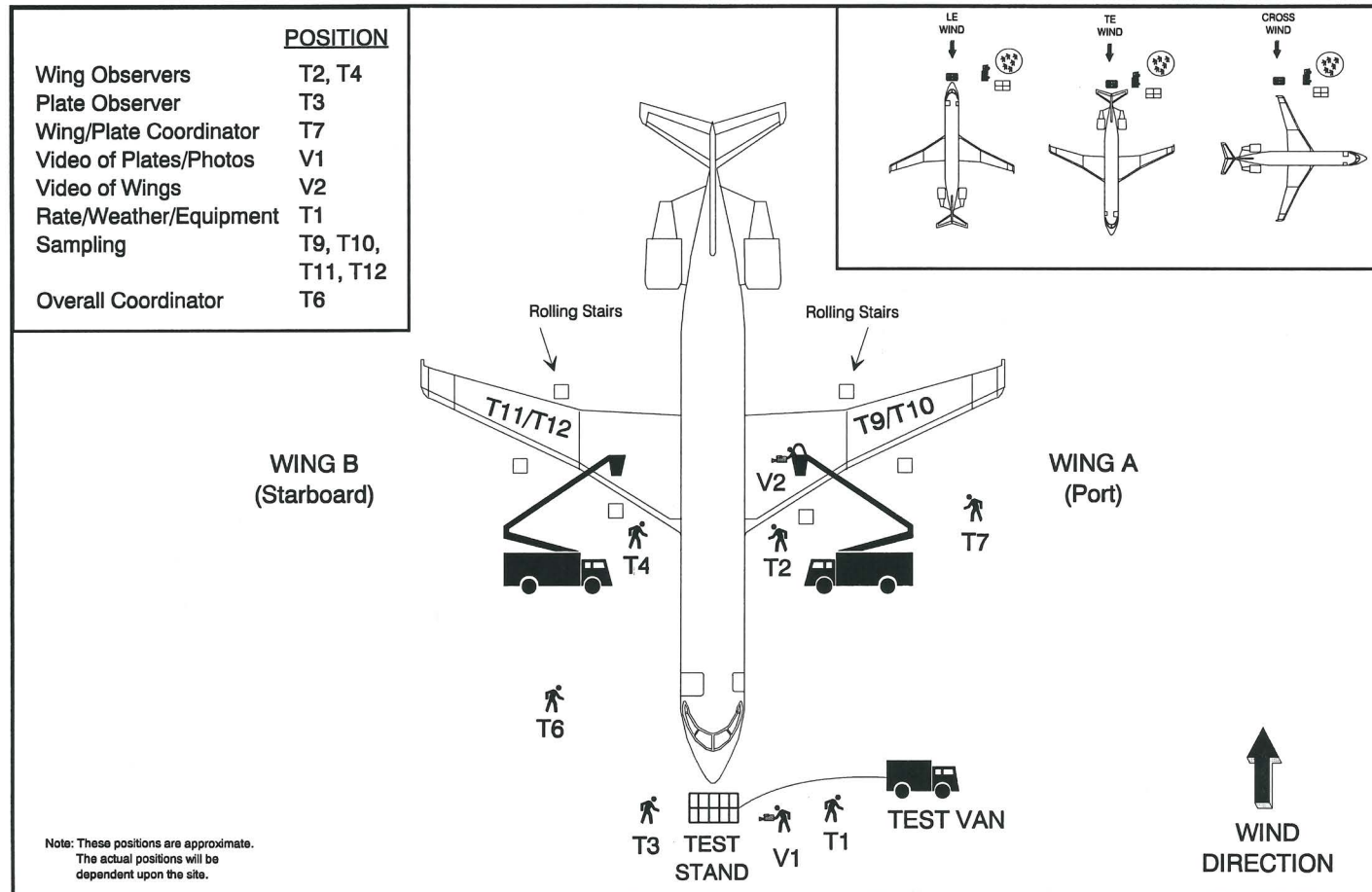


FIGURE 2a
TYPE I FLUID APPLICATION

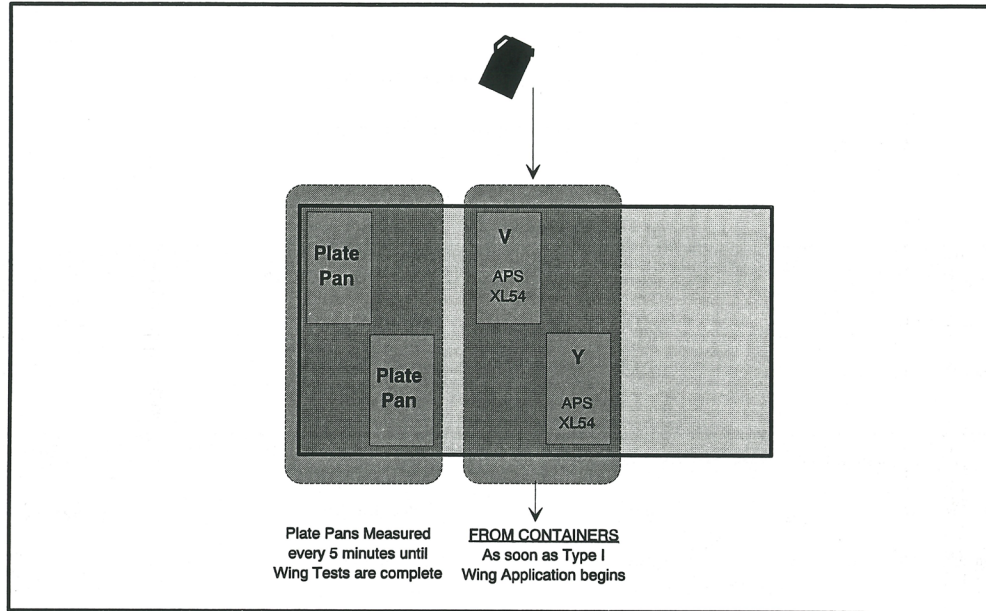
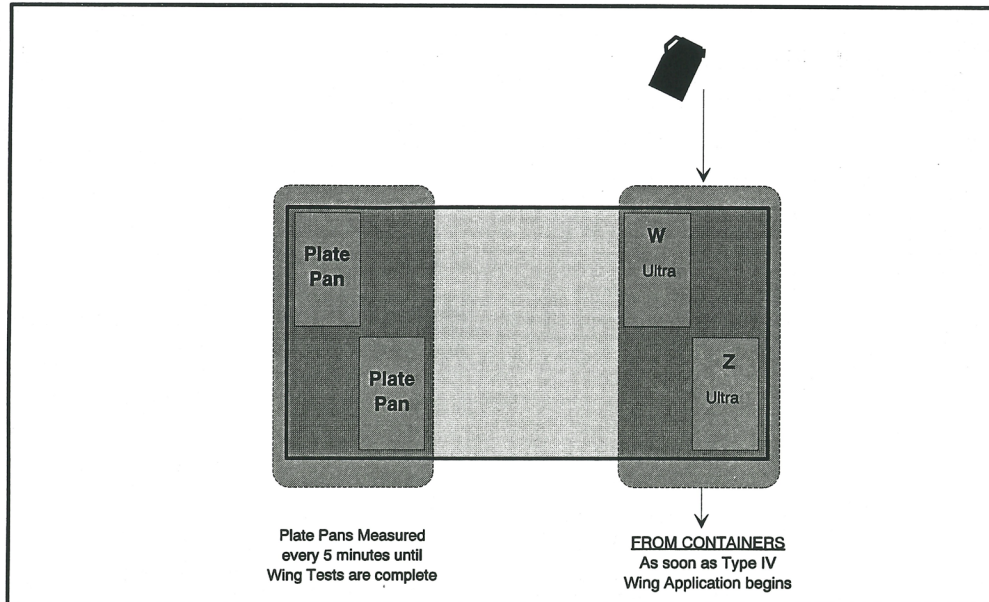


FIGURE 2b
TYPE IV FLUID APPLICATION



B-31

CM1338PROCEDRFPULL_SCI.V1.D_APP1.DRW

**FIGURE 3
GENERAL FORM (EVERY TEST)
(TO BE FILLED IN BY PLATE/WING COORDINATOR)**

DATE: _____ AIRCRAFT TYPE: ATR-42 F-100 B-737 RJ DHC-8

RUN #: _____ WING: PORT (A) STARBOARD (B)

DIRECTION OF AIRCRAFT: _____ DEGREES

DRAW DIRECTION OF WIND WRT WING:



<i>1st FLUID APPLICATION</i>	
Actual Start Time: _____ am / pm	Actual End Time: _____ am / pm
Amount of Fluid Sprayed: _____ L / gal	Type of Fluid: _____
<i>2nd FLUID APPLICATION</i>	
Actual Start Time: _____ am / pm	Actual End Time: _____ am / pm
Amount of Fluid Sprayed: _____ L / gal	Type of Fluid: _____

End of Test Time: _____ (hr:min:ss) am/pm

COMMENTS:

MEASUREMENTS BY: _____

HAND WRITTEN BY: _____

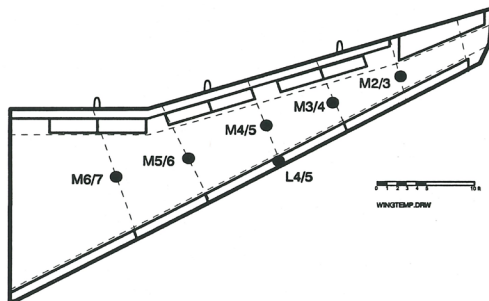
File:g:\cm1338\procedur\full_scl:GFORM3.XLS
 At: GFORM 2
 Printed: 15/01/97

FIGURE 3a
GENERAL FORM (ONCE PER SESSION)
 (TO BE FILLED IN BY OVERALL COORDINATOR)

AIRPORT: YUL YYZ YOW EXACT PAD LOCATION OF TEST: _____ DATE: _____ APPROX. AIR TEMPERATURE: _____ °C	AIRCRAFT TYPE: ATR-42 F-100 B-737 RJ DHC-8 AIRLINE: _____ FIN #: _____ FUEL LOAD: _____ LB / KG
---	--

TYPE I FLUID APPLICATION	TYPE IV FLUID APPLICATION
TYPE I FLUID TEMP: _____ °C Type I Truck #: _____ Type I Fluid Nozzle Type: _____	TYPE IV FLUID TEMP: _____ °C Type IV Truck #: _____ Type IV Fluid Nozzle Type: _____

TEMPERATURE MEASUREMENTS



ENTER FLUID TYPE:						
TIME (min)	TEMPERATURE AT LOCATION (°C)					
	M6/7	M5/6	L4/5	M4/5	M3/4	M2/3
Before ¹						
()						

COMMENTS:

(1) Actual Time Before Fluid Application

MEASUREMENTS BY: _____

HAND WRITTEN BY: _____

File:g:\cm1338\procedur\full_scl:GFORM3.XLS
 At: GFORM 1
 Printed: 15/01/97

FIGURE 4
DE/ANTI-ICING FORM FOR AIRCRAFT WING

VERSION 3.0 Winter 96/97

REMEMBER TO SYNCHRONIZE TIME

DATE: _____	RUN NUMBER: _____
-------------	-------------------

FAILURES CALLED BY: _____

HANDWRITTEN BY: _____

ASSISTED BY: _____

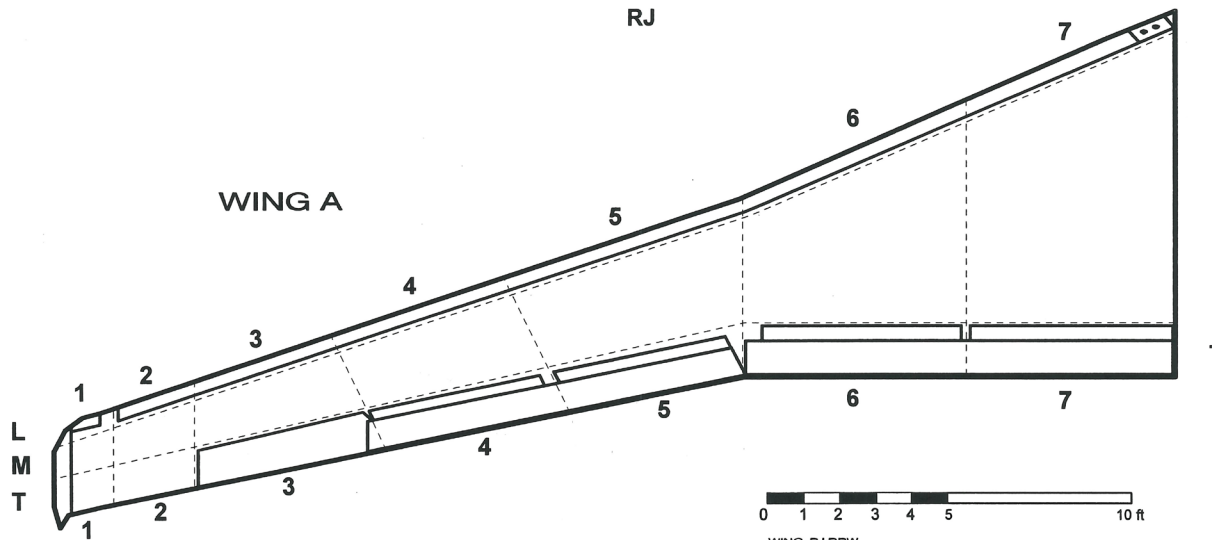
COMMENTS: _____

IMPORTANT EVENTS (hr:min)			
	L.Edge	Mid	T.Edge
1st Failure:	_____	_____	_____
10% :	_____	_____	_____
25% :	_____	_____	_____
75% :	_____	_____	_____
100% :	_____	_____	_____

DRAW FAILURE CONTOURS (hr:min) ACCORDING TO THE PROCEDURE
 (Indicate Representative Surface on Drawing)

File: g:\cm1338\procedur\full_scl\Aform3.drw

B-34



Note: To Compare to Flat Plate testing, subtract "Time of Initial Fluid Application".

File: cm1338\procedur\full-scl\IV3_RJ.XLS
 At Wing A Printed: 15/01/97

FIGURE 4
DE/ANTI-ICING FORM FOR AIRCRAFT WING

VERSION 3.0 Winter 96/97

REMEMBER TO SYNCHRONIZE TIME

DATE: _____	RUN NUMBER: _____
-------------	-------------------

FAILURES CALLED BY: _____

HANDWRITTEN BY: _____

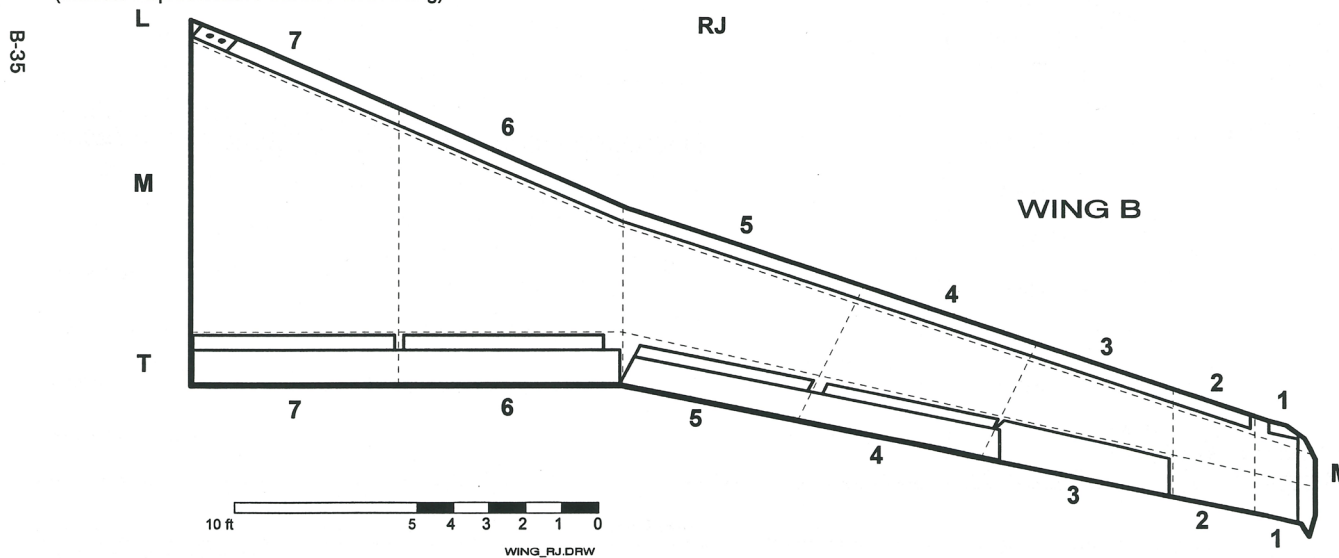
ASSISTED BY: _____

COMMENTS: _____

IMPORTANT EVENTS (hr:min)			
	L.Edge	Mid	T.Edge
1st Failure:	_____	_____	_____
10% :	_____	_____	_____
25% :	_____	_____	_____
75% :	_____	_____	_____
100% :	_____	_____	_____

File: g:\cm1338\procedur\full_scl\Aform3.drw

DRAW FAILURE CONTOURS (hr:min) ACCORDING TO THE PROCEDURE
 (Indicate Representative Surface on Drawing)



File: cm1338\procedur\full-scl\V3_RJ.XLS
 At: Wing B Printed: 15/01/97

Note: To Compare to Flat Plate testing, subtract "Time of Initial Fluid Application".

FIGURE 4
DE/ANTI-ICING FORM FOR AIRCRAFT WING

VERSION 3.0 Winter 96/97

REMEMBER TO SYNCHRONIZE TIME

DATE: _____ RUN NUMBER: _____

FAILURES CALLED BY: _____

HANDWRITTEN BY: _____

ASSISTED BY: _____

COMMENTS: _____

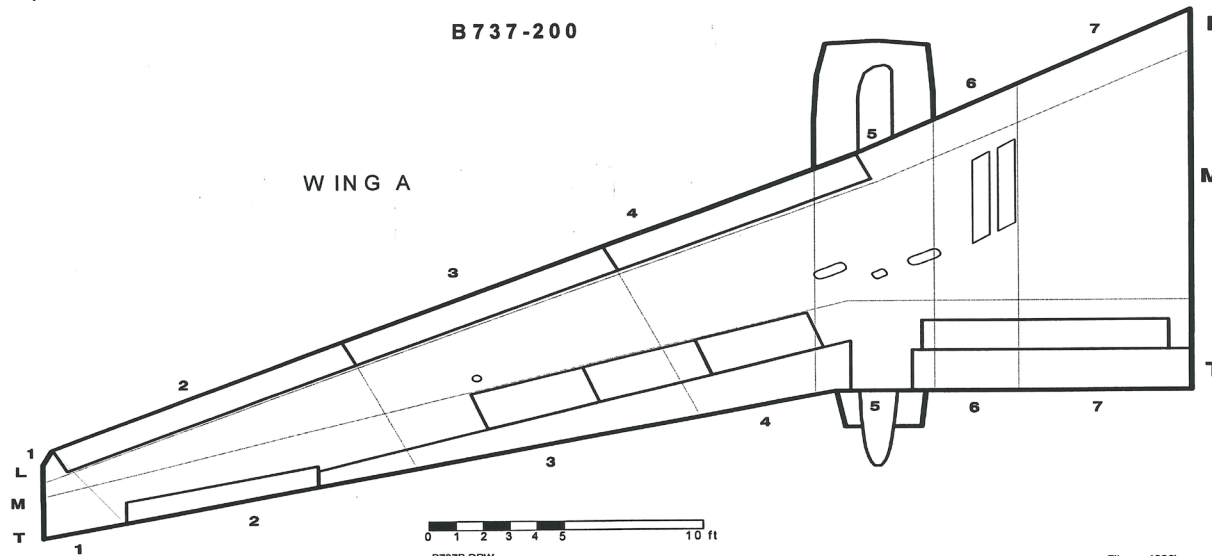
IMPORTANT EVENTS (hr:min)			
	<u>L.Edge</u>	<u>Mid</u>	<u>T.Edge</u>
1st Failure:	_____	_____	_____
10% :	_____	_____	_____
25% :	_____	_____	_____
75% :	_____	_____	_____
100% :	_____	_____	_____

DRAW FAILURE CONTOURS (hr:min) ACCORDING TO THE PROCEDURE
 (Indicate Representative Surface on Drawing)

File: g:\cm1338\procedur\full_scl\Aform3.drw

B-36

B 737 -200



Note: To Compare to Flat Plate testing, subtract "Time of Initial Fluid Application".

File: cm1338\procedur\full-scl\V3_B737.XLS
 At: Wing A Printed: 15/01/97

FIGURE 4
DE/ANTI-ICING FORM FOR AIRCRAFT WING

VERSION 3.0 Winter 96/97

REMEMBER TO SYNCHRONIZE TIME

DATE: _____ RUN NUMBER: _____

FAILURES CALLED BY: _____

HANDWRITTEN BY: _____

ASSISTED BY: _____

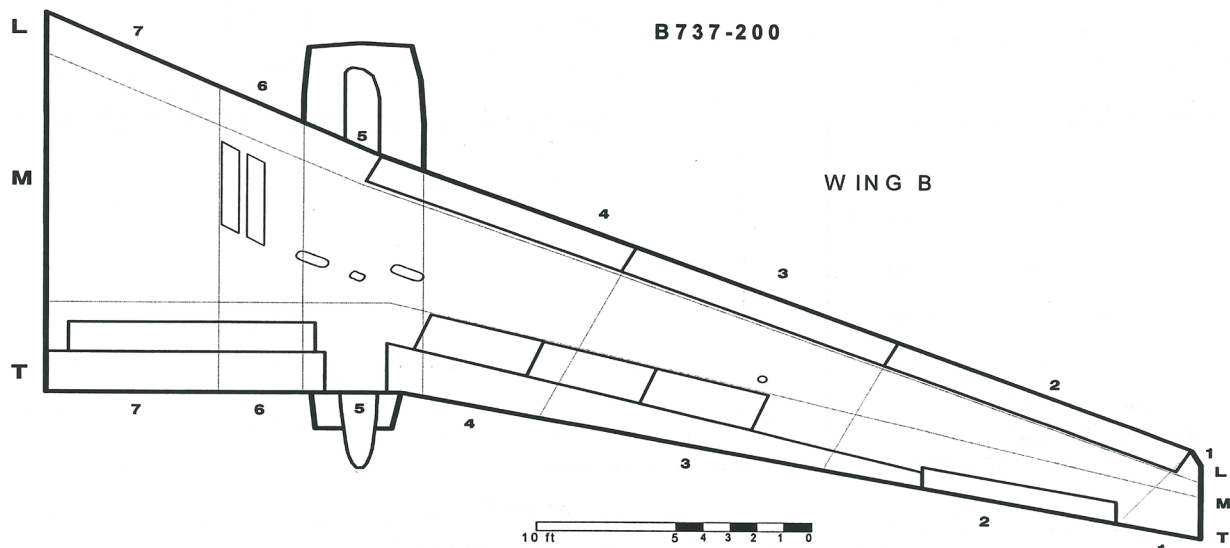
COMMENTS: _____

IMPORTANT EVENTS (hr:min)			
	L.Edge	Mid	T.Edge
1st Failure:	_____	_____	_____
10% :	_____	_____	_____
25% :	_____	_____	_____
75% :	_____	_____	_____
100% :	_____	_____	_____

DRAW FAILURE CONTOURS (hr:min) ACCORDING TO THE PROCEDURE
(Indicate Representative Surface on Drawing)

File: g:\cm1338\procedur\full_scl\Aform3.drw

B-37



Note: To Compare to Flat Plate testing, subtract "Time of Initial Fluid Application".

B737B.DRW

File: cm1338\procedur\full_scl\W3_B737.XLS
At: Wing B Printed: 15/01/97

FIGURE 4
DE/ANTI-ICING FORM FOR AIRCRAFT WING

VERSION 3.0 Winter 96/97

REMEMBER TO SYNCHRONIZE TIME

DATE: _____ RUN NUMBER: _____

FAILURES CALLED BY: _____

HANDWRITTEN BY: _____

ASSISTED BY: _____

COMMENTS: _____

IMPORTANT EVENTS (hr:min)			
	<u>L.Edge</u>	<u>Mid</u>	<u>T.Edge</u>
1st Failure:	_____	_____	_____
10% :	_____	_____	_____
25% :	_____	_____	_____
75% :	_____	_____	_____
100% :	_____	_____	_____

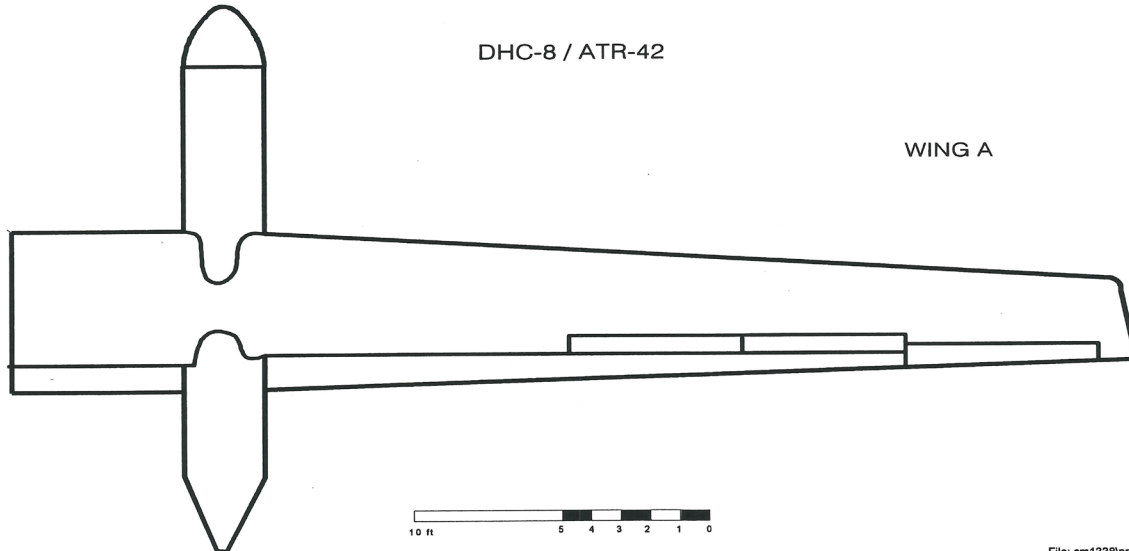
File: g:\cm1338\procedur\full_scl\Aform3.dr

DRAW FAILURE CONTOURS (hr:min) ACCORDING TO THE PROCEDURE
 (Indicate Representative Surface on Drawing)

B-38

DHC-8 / ATR-42

WING A



Note: To Compare to Flat Plate testing, subtract "Time of Initial Fluid Application".

File: cm1338\procedur\full-scl\DASH8_WA.XLS
 At Wing A Printed: 15/01/97

FIGURE 4
DE/ANTI-ICING FORM FOR AIRCRAFT WING

REMEMBER TO SYNCHRONIZE TIME

VERSION 3.0

Winter 96/97

DATE: _____ RUN NUMBER: _____

FAILURES CALLED BY: _____

HANDWRITTEN BY: _____

ASSISTED BY: _____

COMMENTS: _____

IMPORTANT EVENTS (hr:min)			
	L.Edge	Mid	T.Edge
1st Failure:	_____	_____	_____
10% :	_____	_____	_____
25% :	_____	_____	_____
75% :	_____	_____	_____
100% :	_____	_____	_____

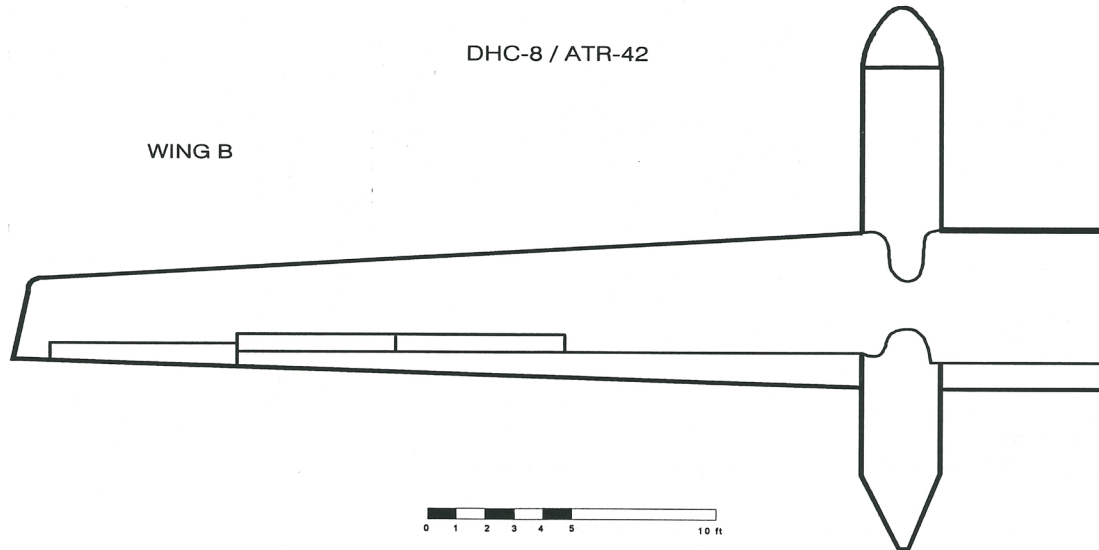
DRAW FAILURE CONTOURS (hr:min) ACCORDING TO THE PROCEDURE
(Indicate Representative Surface on Drawing)

File: g:\cm1338\procedur\full_scl\Aform3.dr

B-39

DHC-8 / ATR-42

WING B



Note: To Compare to Flat Plate testing, subtract "Time of Initial Fluid Application".

File: cm1338\procedur\full-scl\DASH8_WB.XLS
At: Wing b Printed: 15/01/97

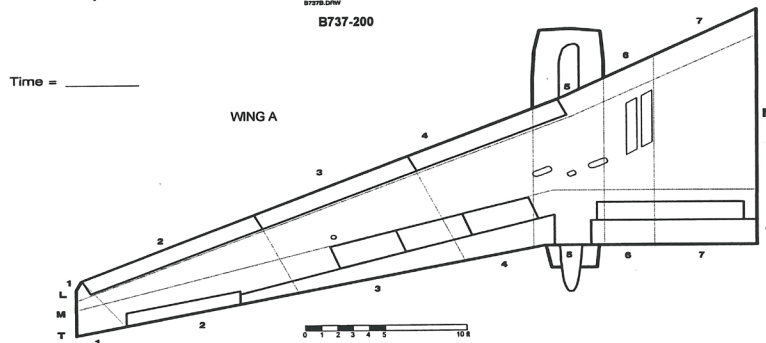
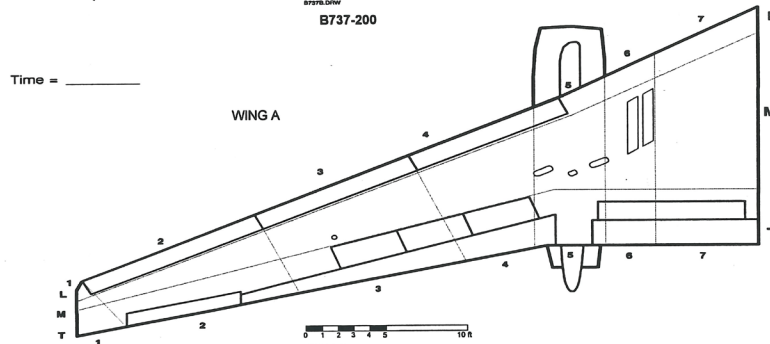
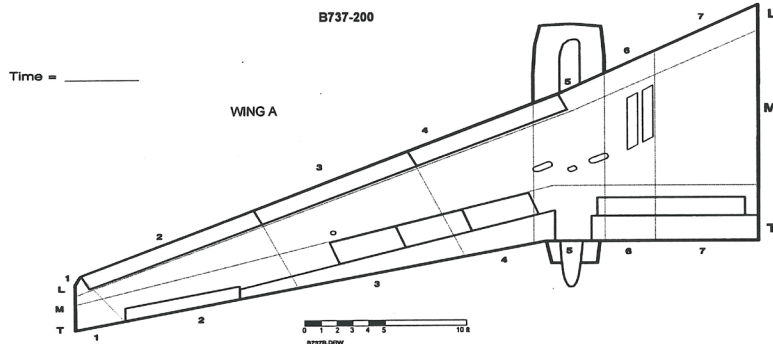
FIGURE 4
DE/ANTI-ICING FORM FOR AIRCRAFT WING

VERSION 4.0 Winter 06/97

REMEMBER TO SYNCHRONIZE TIME																						
DATE: _____	RUN NUMBER: _____																					
FAILURES CALLED BY: _____	<table border="1"> <thead> <tr> <th colspan="3">IMPORTANT EVENTS (hr:min)</th> </tr> <tr> <th>L.Edge</th> <th>Mid</th> <th>T.Edge</th> </tr> </thead> <tbody> <tr> <td>1st Failure: _____</td> <td>_____</td> <td>_____</td> </tr> <tr> <td>10% : _____</td> <td>_____</td> <td>_____</td> </tr> <tr> <td>25% : _____</td> <td>_____</td> <td>_____</td> </tr> <tr> <td>75% : _____</td> <td>_____</td> <td>_____</td> </tr> <tr> <td>100% : _____</td> <td>_____</td> <td>_____</td> </tr> </tbody> </table>	IMPORTANT EVENTS (hr:min)			L.Edge	Mid	T.Edge	1st Failure: _____	_____	_____	10% : _____	_____	_____	25% : _____	_____	_____	75% : _____	_____	_____	100% : _____	_____	_____
IMPORTANT EVENTS (hr:min)																						
L.Edge		Mid	T.Edge																			
1st Failure: _____		_____	_____																			
10% : _____		_____	_____																			
25% : _____	_____	_____																				
75% : _____	_____	_____																				
100% : _____	_____	_____																				
HANDWRITTEN BY: _____																						
ASSISTED BY: _____																						
COMMENTS: _____																						

DRAW FAILURE CONTOURS (hr:min) ACCORDING TO THE PROCEDURE
(Indicate Representative Surface on Drawing)

File: g:\cm1338\procedur\full_scl\Aform3.dr



Note: To Compare to Flat Plate testing, subtract "Time of Initial Fluid Application".

B-40

File: cm1338\procedur\full_scl\A_8737.XLS
At: Wing A. Printed: 2/20/97

FIGURE 4
DE/ANTI-ICING FORM FOR AIRCRAFT WING

REMEMBER TO SYNCHRONIZE TIME

DATE: _____ RUN NUMBER: _____

VERSION 4.0 Water 6997

FAILURES CALLED BY: _____

HANDWRITTEN BY: _____

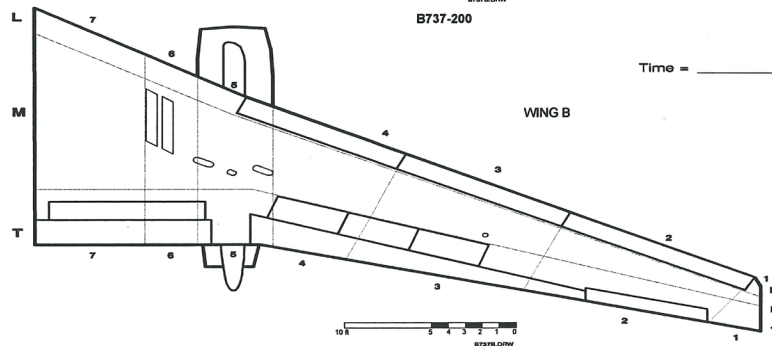
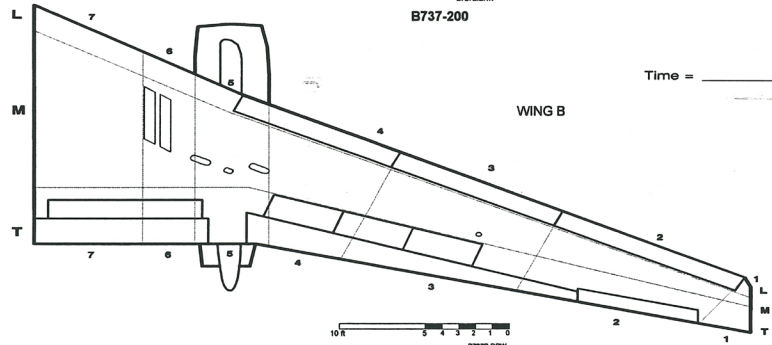
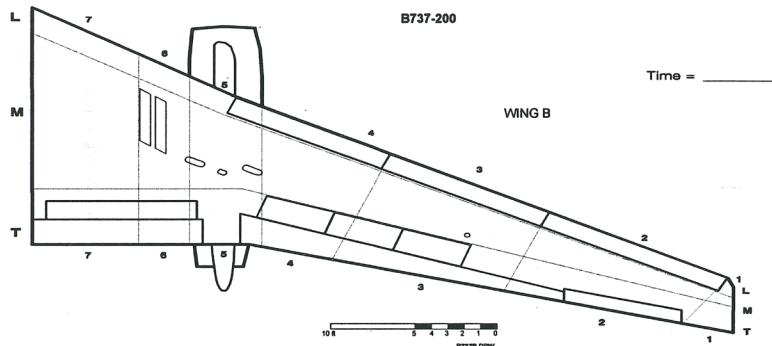
ASSISTED BY: _____

COMMENTS: _____

DRAW FAILURE CONTOURS (hr:min) ACCORDING TO THE PROCEDURE
(Indicate Representative Surface on Drawing)

IMPORTANT EVENTS (hr:min)			
	L.Edge	Mid	T.Edge
1st Failure:	_____	_____	_____
10% :	_____	_____	_____
25% :	_____	_____	_____
75% :	_____	_____	_____
100% :	_____	_____	_____

File: g:\cm1338\procedur\full_scl\Aform3.dr



Note: To Compare to Flat Plate testing, subtract "Time of Initial Fluid Application".

B-41

File: cm1338\procedur\66-ec\IV4_B737.XLS
At: Wing B Printed: 27/01/97

FIGURE 4
DE/ANTI-ICING FORM FOR AIRCRAFT WING

REMEMBER TO SYNCHRONIZE TIME

DATE: _____ RUN NUMBER: _____ VERSION 4.0 Winter 99/97

FAILURES CALLED BY: _____

HANDWRITTEN BY: _____

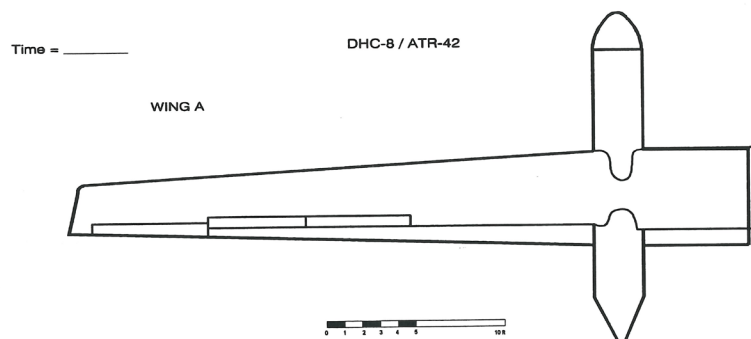
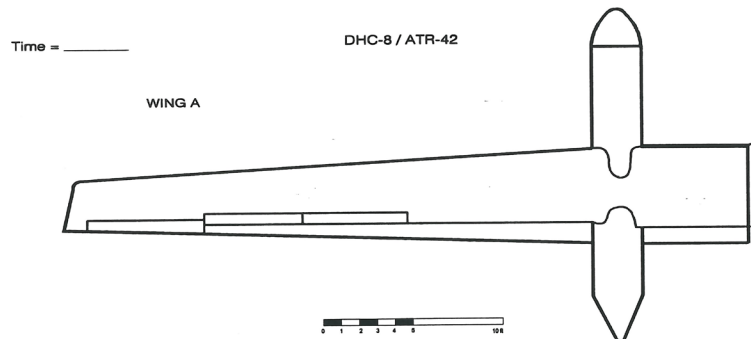
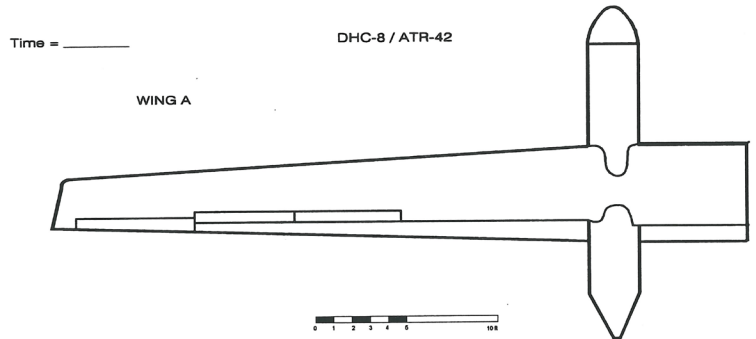
ASSISTED BY: _____

COMMENTS: _____

DRAW FAILURE CONTOURS (hr:min) ACCORDING TO THE PROCEDURE
(Indicate Representative Surface on Drawing)

IMPORTANT EVENTS (hr:min)			
	L.Edge	Mid	T.Edge
1st Failure:	_____	_____	_____
10% :	_____	_____	_____
25% :	_____	_____	_____
75% :	_____	_____	_____
100% :	_____	_____	_____

File: g:\cm1338\procedur\full_scl\Aform3.dwg



Note: To Compare to Flat Plate testing, subtract "Time of Initial Fluid Application".

B-42

File: km1338\procedur\barbopel\W4_D8_A3L8
At: Wing A Printed: 97-1-19

FIGURE 4
DE/ANTI-ICING FORM FOR AIRCRAFT WING

REMEMBER TO SYNCHRONIZE TIME

DATE: _____ RUN NUMBER: _____ VERSION 4.0 Water 9997

FAILURES CALLED BY: _____

HANDWRITTEN BY: _____

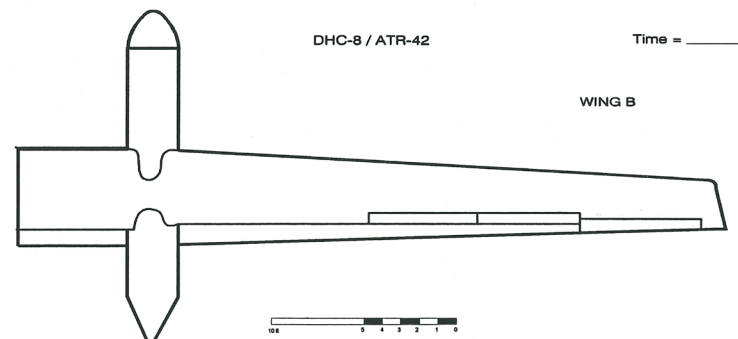
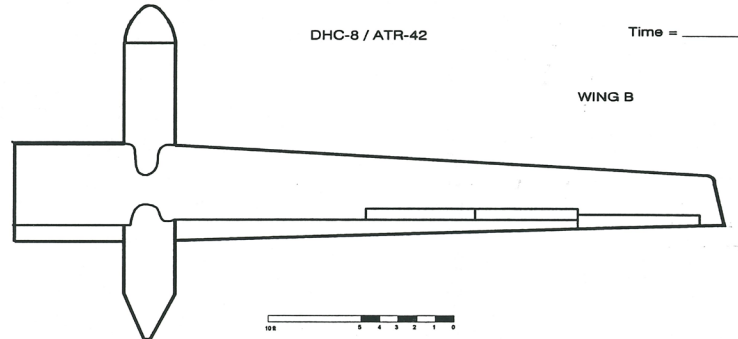
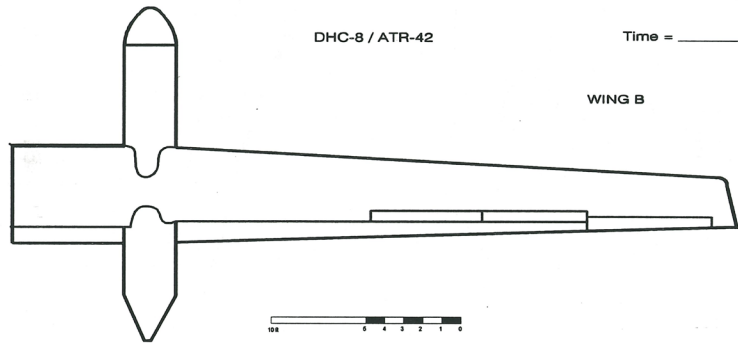
ASSISTED BY: _____

COMMENTS: _____

DRAW FAILURE CONTOURS (hr:min) ACCORDING TO THE PROCEDURE
(Indicate Representative Surface on Drawing)

IMPORTANT EVENTS (hr:min)			
	L.Edge	Mid	T.Edge
1st Failure:	_____	_____	_____
10% :	_____	_____	_____
25% :	_____	_____	_____
75% :	_____	_____	_____
100% :	_____	_____	_____

File: g:\cm1338\procedur\ful_sctAform3.drw



Note: To Compare to Flat Plate testing, subtract "Time of Initial Fluid Application".

File: g:\cm1338\procedur\ful_sctAform3.drw

B-43

FIGURE 4
DE/ANTI-ICING FORM FOR AIRCRAFT WING

VERSION 3.0 Winter 96/97

REMEMBER TO SYNCHRONIZE TIME

DATE: _____ RUN NUMBER: _____

FAILURES CALLED BY: _____

HANDWRITTEN BY: _____

ASSISTED BY: _____

COMMENTS: _____

IMPORTANT EVENTS (hr:min)			
	<u>L.Edge</u>	<u>Mid</u>	<u>T.Edge</u>
1st Failure:	_____	_____	_____
10% :	_____	_____	_____
25% :	_____	_____	_____
75% :	_____	_____	_____
100% :	_____	_____	_____

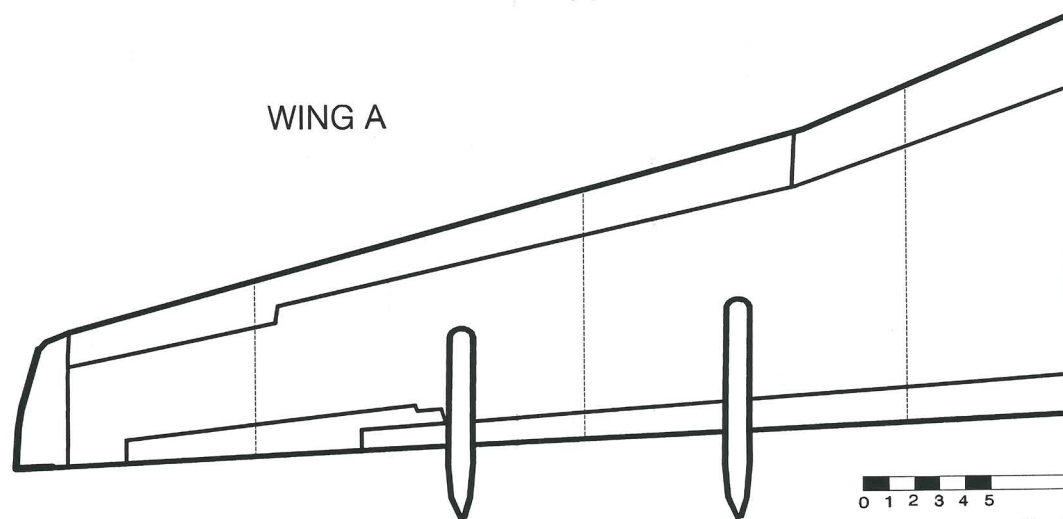
File: g:\cm1338\procedur\full_scl\Aform3.drw

DRAW FAILURE CONTOURS (hr:min) ACCORDING TO THE PROCEDURE
(Indicate Representative Surface on Drawing)

F-100

B-44

WING A



Note: To Compare to Flat Plate testing, subtract "Time of Initial Fluid Application".

File: cm1338\procedur\full-scl\V3_F100.XLS
At: Wing A Printed: 15/01/97

FIGURE 4
DE/ANTI-ICING FORM FOR AIRCRAFT WING

REMEMBER TO SYNCHRONIZE TIME

DATE: _____ RUN NUMBER: _____ VERSION 4.0 Water 9907

FAILURES CALLED BY: _____

HANDWRITTEN BY: _____

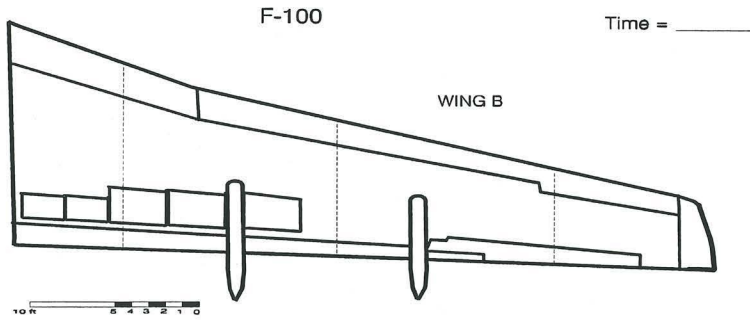
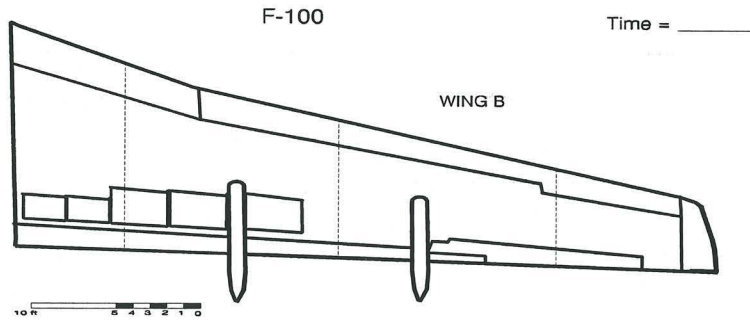
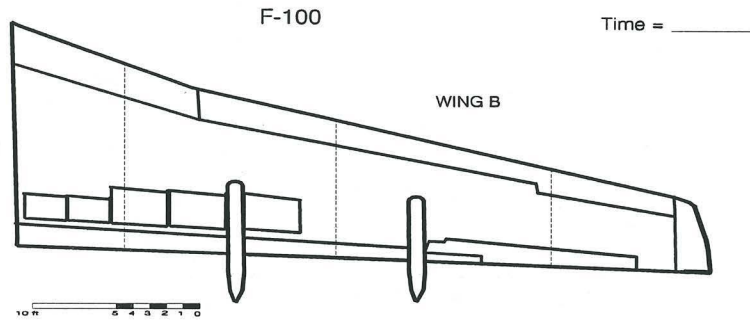
ASSISTED BY: _____

COMMENTS: _____

DRAW FAILURE CONTOURS (hr:min) ACCORDING TO THE PROCEDURE
(Indicate Representative Surface on Drawing)

IMPORTANT EVENTS (hr:min)			
	L.Edge	Mid	T.Edge
1st Failure:	_____	_____	_____
10% :	_____	_____	_____
25% :	_____	_____	_____
75% :	_____	_____	_____
100% :	_____	_____	_____

File: g:\cm1338\procedur\full_sclAform3.dwg



Note: To Compare to Flat Plate testing, subtract "Time of Initial Fluid Application".

File: cm1338\procedur\full_sclA\F100.XLS
At: WING B Printed: 2/22/97

B-45

FIGURE 4
DE/ANTI-ICING FORM FOR AIRCRAFT WING

REMEMBER TO SYNCHRONIZE TIME

DATE: _____ RUN NUMBER: _____ VERSION 4.0 Winter 99/97

FAILURES CALLED BY: _____

HANDWRITTEN BY: _____

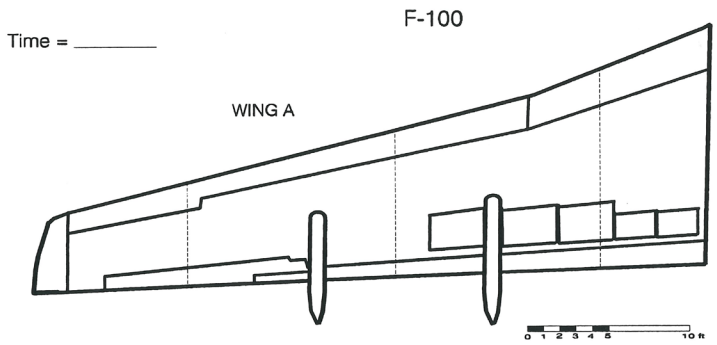
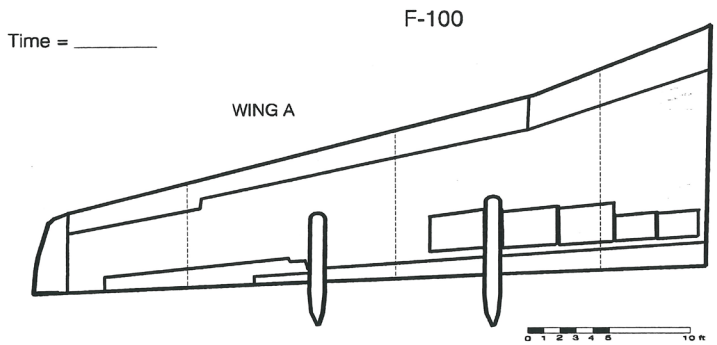
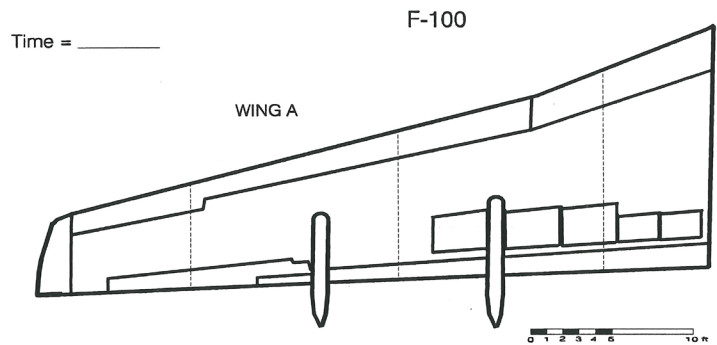
ASSISTED BY: _____

COMMENTS: _____

DRAW FAILURE CONTOURS (hr:min) ACCORDING TO THE PROCEDURE
(Indicate Representative Surface on Drawing)

	IMPORTANT EVENTS (hr:min)		
	L.Edge	Mid	T.Edge
1st Failure:	_____	_____	_____
10% :	_____	_____	_____
25% :	_____	_____	_____
75% :	_____	_____	_____
100% :	_____	_____	_____

File: g:\cm1338\procedur\full_scl\Aform3.drw



Note: To Compare to Flat Plate testing, subtract "Time of Initial Fluid Application"

File: cm1338\procedur\full_scl\F100.XLS
At: Wing A. Printed: 3/25/97

B-46

FIGURE 4
DE/ANTI-ICING FORM FOR AIRCRAFT WING

VERSION 3.0 Winter 96/97

REMEMBER TO SYNCHRONIZE TIME

DATE: _____ RUN NUMBER: _____

FAILURES CALLED BY: _____

HANDWRITTEN BY: _____

ASSISTED BY: _____

COMMENTS: _____

IMPORTANT EVENTS (hr:min)			
	<u>L.Edge</u>	<u>Mid</u>	<u>T.Edge</u>
1st Failure:	_____	_____	_____
10% :	_____	_____	_____
25% :	_____	_____	_____
75% :	_____	_____	_____
100% :	_____	_____	_____

File: g:\cm1338\procedur\full_scl\Aform3.drw

DRAW FAILURE CONTOURS (hr:min) ACCORDING TO THE PROCEDURE
(Indicate Representative Surface on Drawing)

F-100

B-47

WING B



Note: To Compare to Flat Plate testing, subtract "Time of Initial Fluid Application".

File: cm1338\procedur\full-scl\V3_F100.XLS
At: Wing B Printed: 15/01/97

FIGURE 5
SAMPLING DATA FORM

RUN #: _____

DATE: _____

- Take clean Type I & Type IV Fluid samples once in evening from containers and truck (Four samples are required)

Time of Plate Sample: _____

Plate Identification: _____

		1st Wing Sampling	2nd Wing Sampling	3rd Wing Sampling	4th Wing Sampling
Start Time					
End Time					

THICKNESS MEASUREMENTS

Location	After Fluid Application	Gauge	Time	Gauge	Time	Gauge	Time	Gauge	Time	Gauge
3										
4										
10										

Comments: _____

Sample Taken by: _____

Handwritten by: _____

Approved by: _____

g:\cm1338\procedurfull_scl\SF\FORM-1.XLS
 At: Sampling
 Printed: 21/01/97

FIGURE 6
FLUID THICKNESS GENERAL FORM

AIRPORT: YUL YYZ YOW

AIRCRAFT TYPE: ATR-42 F-100 B-737 RJ DHC-8

DATE: _____

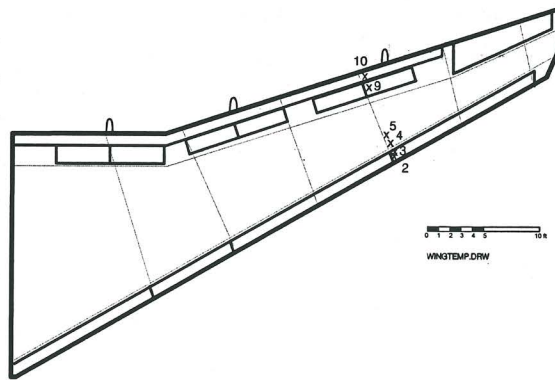
RUN #: _____

TYPE OF FLUID APPLIED: _____

TIME FLUID APPLIED: _____

Measurement Location	Time	Gauge	Time	Gauge	Time	Gauge	Time	Gauge	Time	Gauge
2										
3										
4										
5										
9										
10										

COMMENTS: _____



MEASUREMENTS BY: _____

HAND WRITTEN BY: _____

B-49

Version 1.0
 File:g:\cm1338\procedur\full_scl\THCK_FRM.XLS
 Printed: 15/01/97

TABLE 1
END CONDITION DATA FORM

REMEMBER TO SYNCHRONIZE TIME WITH AES - USE REAL TIME

VERSION 4.0

Winter 96/97

LOCATION:	DATE:	RUN #:	STAND #:
-----------	-------	--------	----------

RVSI Series #: _____

CIRCLE SENSOR PLATE: u v w x y z

SENSOR NAME: _____

DIRECTION OF STAND: _____ °

OTHER COMMENTS (Fluid Batch, etc):

B-50

	PRINT	SIGN
FAILURES CALLED BY :	_____	_____
HAND WRITTEN BY :	_____	_____
TEST SITE LEADER :	_____	_____

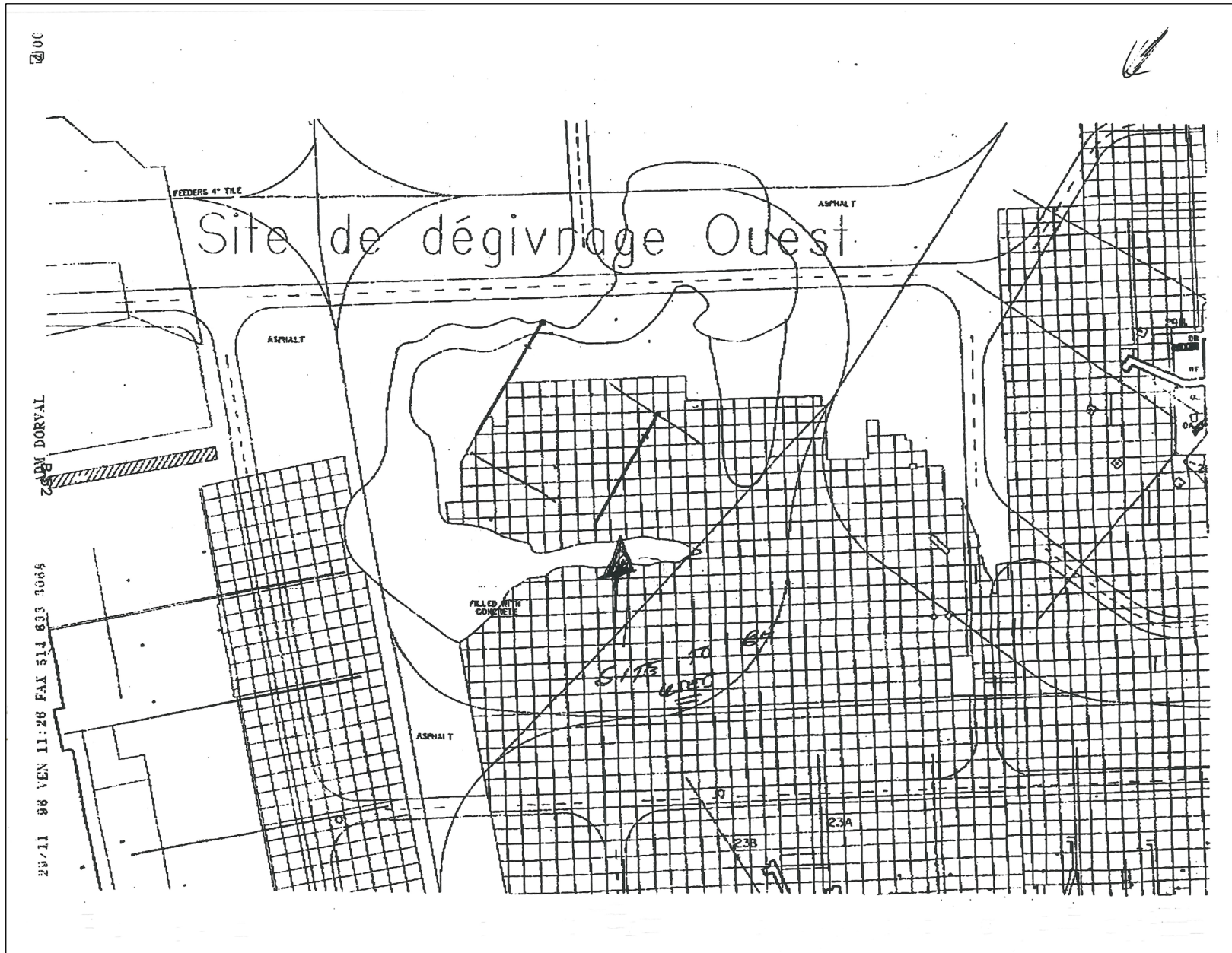
*TIME (After Fluid Application) TO FAILURE FOR INDIVIDUAL CROSSHAIRS (hr:min)

Time of Fluid Application: _____ hr:min (U & X) _____ hr:min (V & Y) _____ hr:min (W & Z)

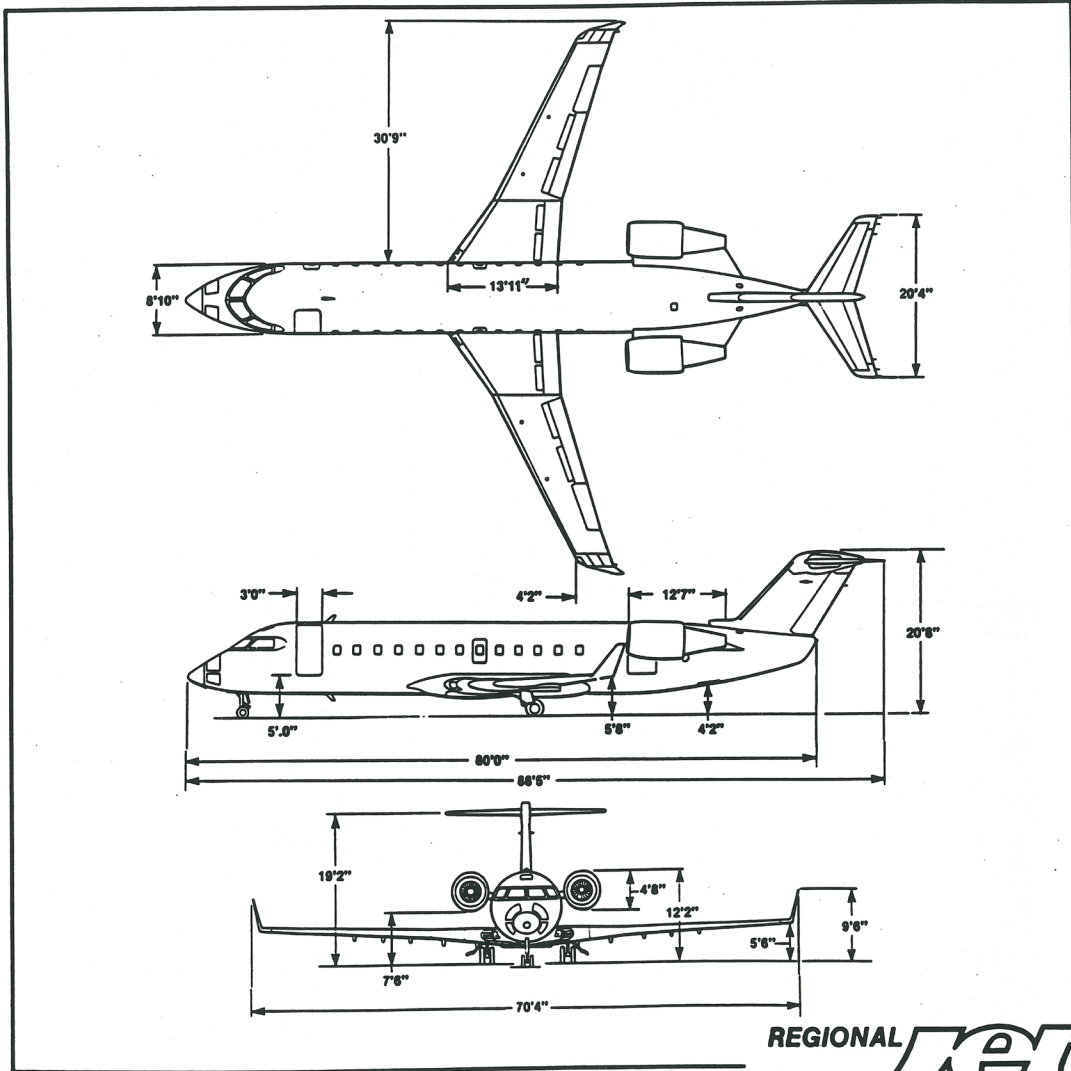
	Plate U	Plate V	Plate W
FLUID NAME			
B1 B2 B3	<input type="text"/>	<input type="text"/>	<input type="text"/>
C1 C2 C3	<input type="text"/>	<input type="text"/>	<input type="text"/>
D1 D2 D3	<input type="text"/>	<input type="text"/>	<input type="text"/>
E1 E2 E3	<input type="text"/>	<input type="text"/>	<input type="text"/>
F1 F2 F3	<input type="text"/>	<input type="text"/>	<input type="text"/>
TIME TO FIRST PLATE FAILURE WITHIN WORK AREA	<input type="text"/>	<input type="text"/>	<input type="text"/>
CALCULATED FAILURE TIME (MINUTES)	<input type="text"/>	<input type="text"/>	<input type="text"/>

	Plate X	Plate Y	Plate Z
FLUID NAME			
B1 B2 B3	<input type="text"/>	<input type="text"/>	<input type="text"/>
C1 C2 C3	<input type="text"/>	<input type="text"/>	<input type="text"/>
D1 D2 D3	<input type="text"/>	<input type="text"/>	<input type="text"/>
E1 E2 E3	<input type="text"/>	<input type="text"/>	<input type="text"/>
F1 F2 F3	<input type="text"/>	<input type="text"/>	<input type="text"/>
TIME TO FIRST PLATE FAILURE WITHIN WORK AREA	<input type="text"/>	<input type="text"/>	<input type="text"/>
CALCULATED FAILURE TIME (MINUTES)	<input type="text"/>	<input type="text"/>	<input type="text"/>

File:g:\cm1338\procedur\nat_snow\PFFORM4.XLS
At: Data Form Printed: 15/01/97



General Arrangement

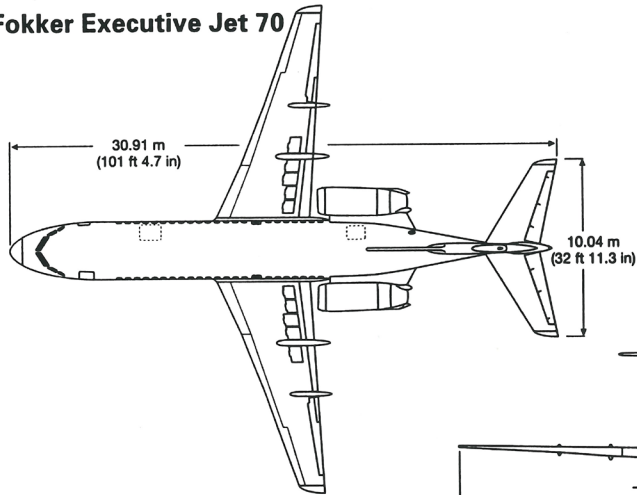


All data presented in this document are strictly based on preliminary estimates.
 Canadair does not make or intend to make any commitment, representation, or warranties whatsoever.
 All data subject to change without prior notice by Canadair.

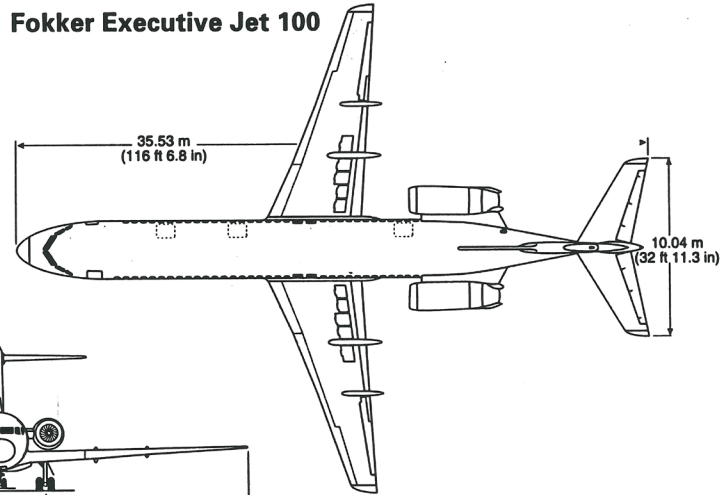


EXTERIOR DIMENSIONS

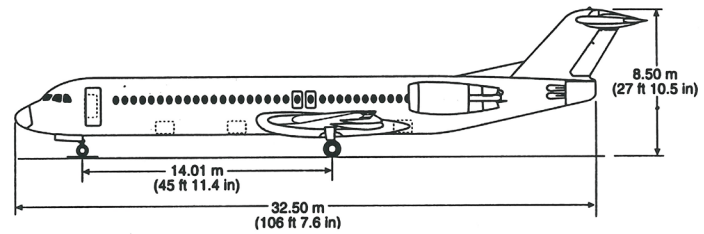
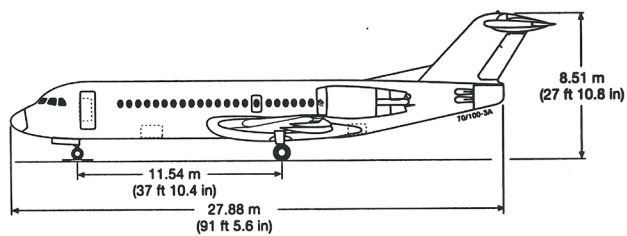
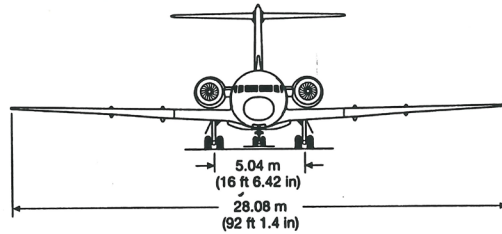
Fokker Executive Jet 70



Fokker Executive Jet 100

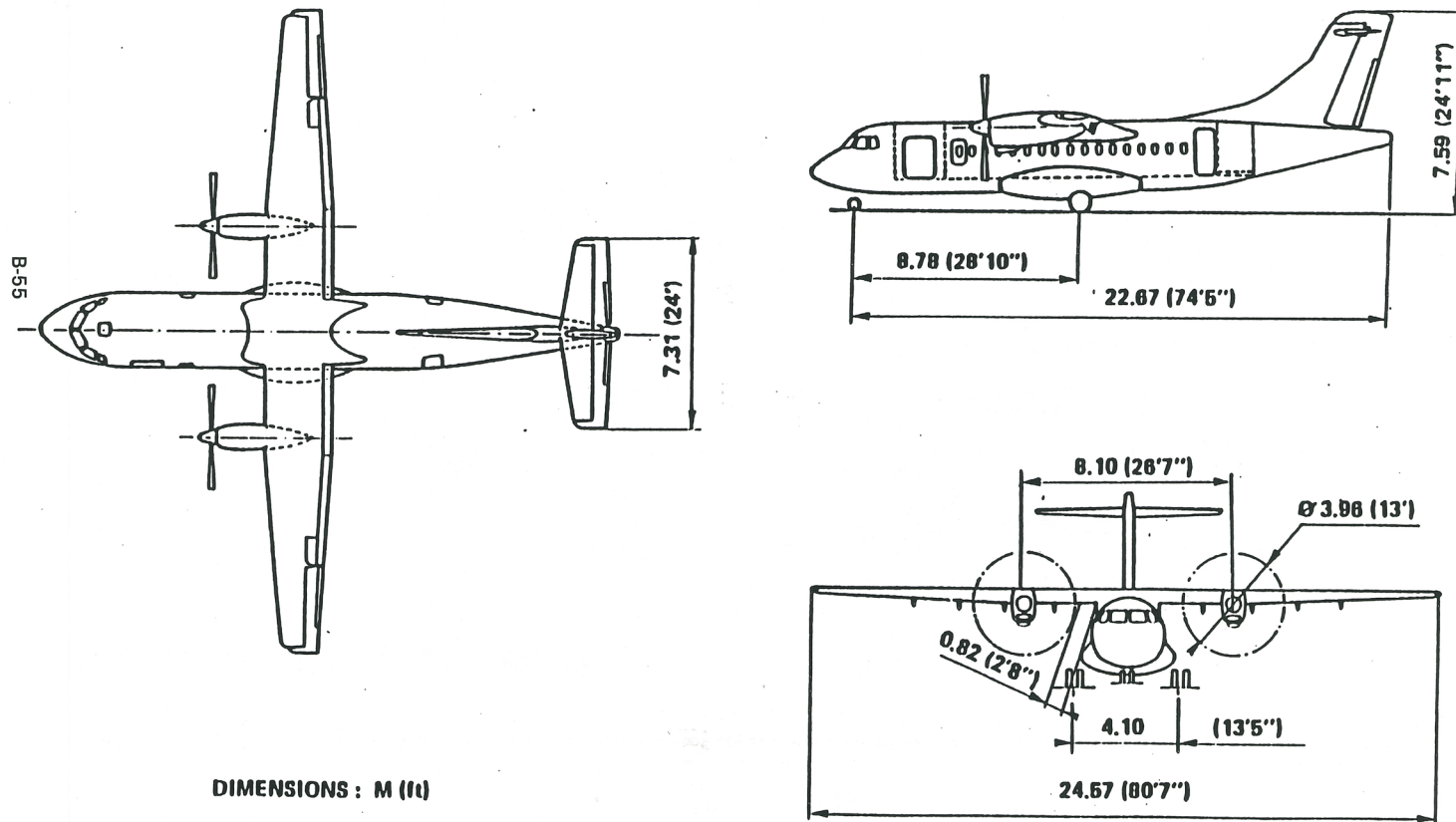


B-54



AR42

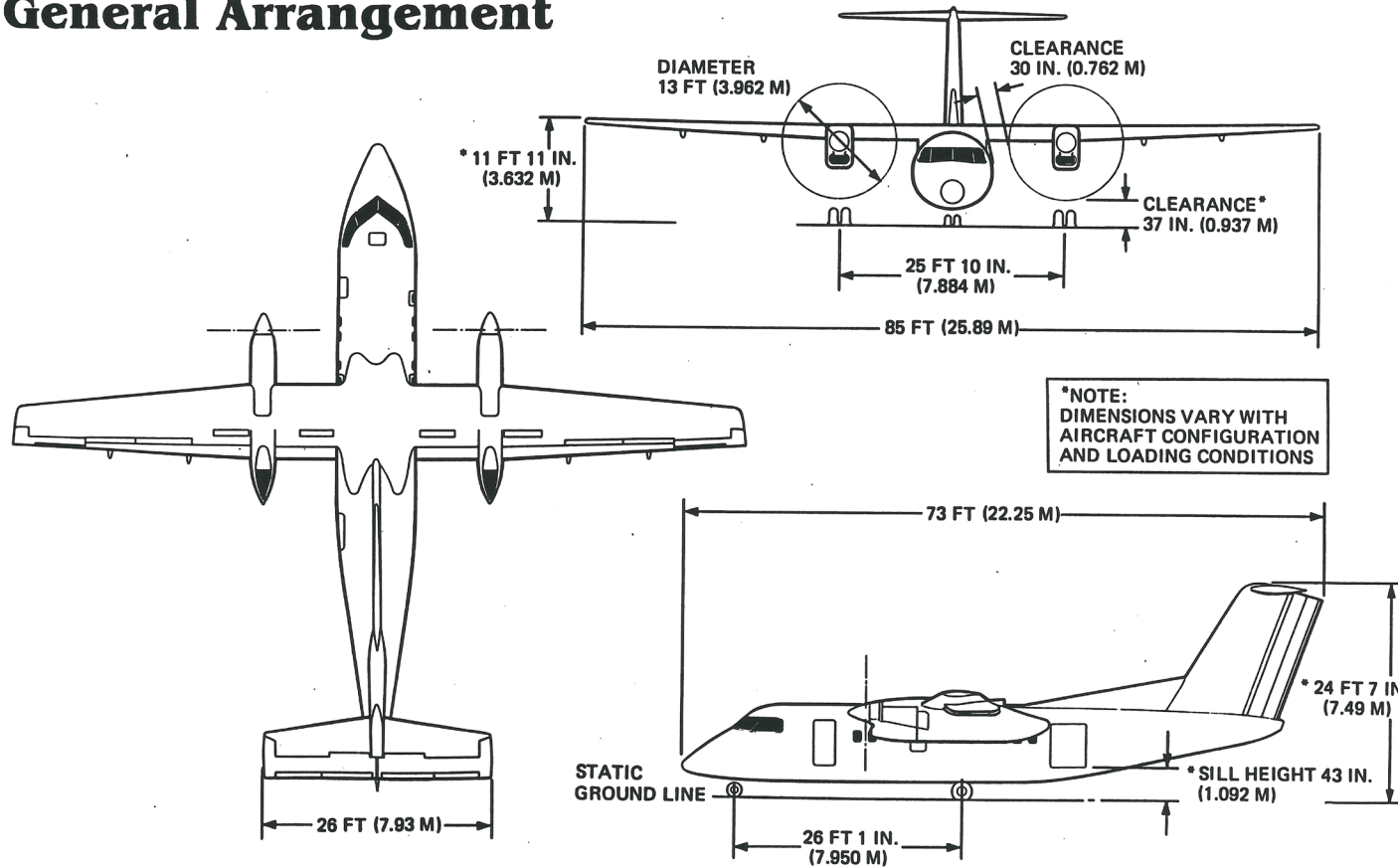
THREE VIEW DRAWING

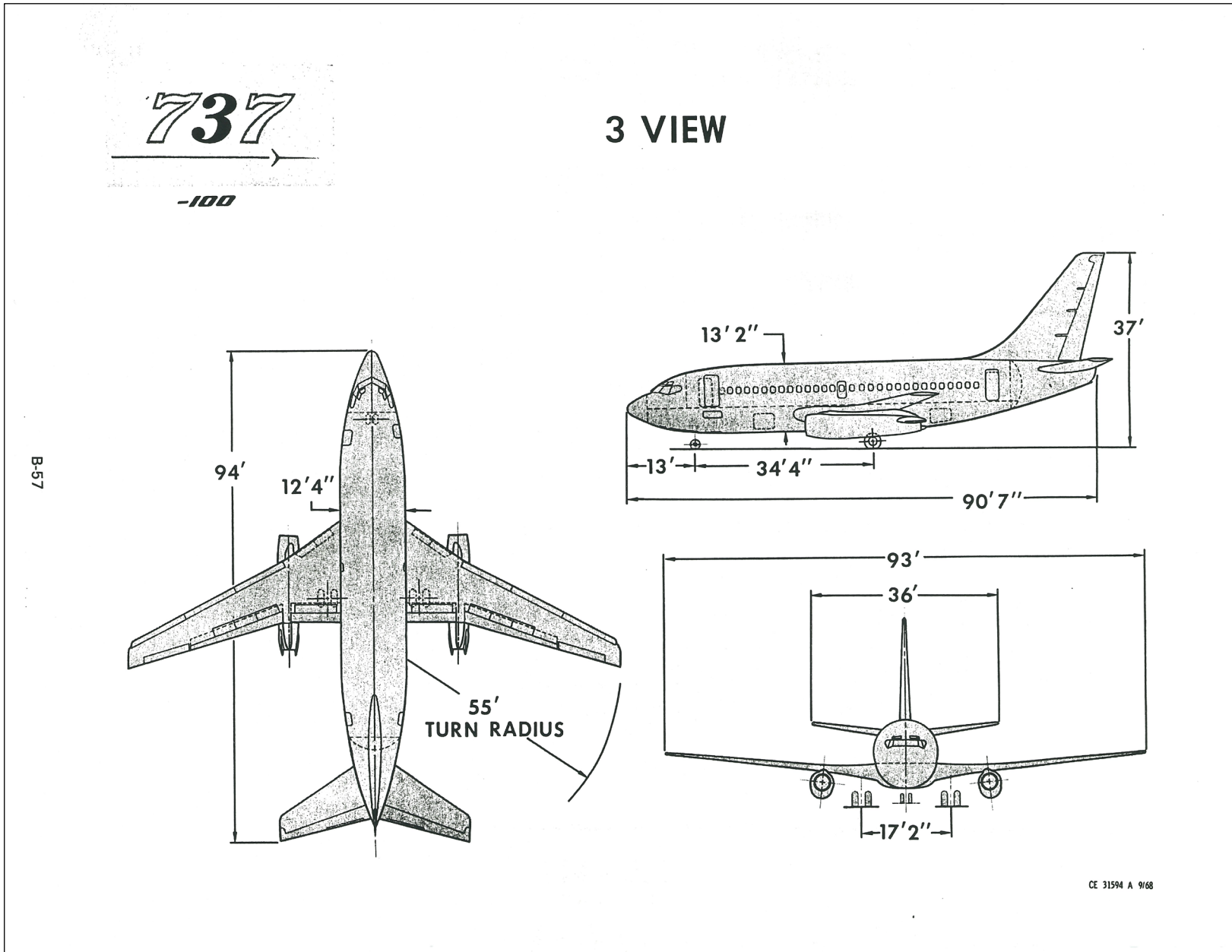


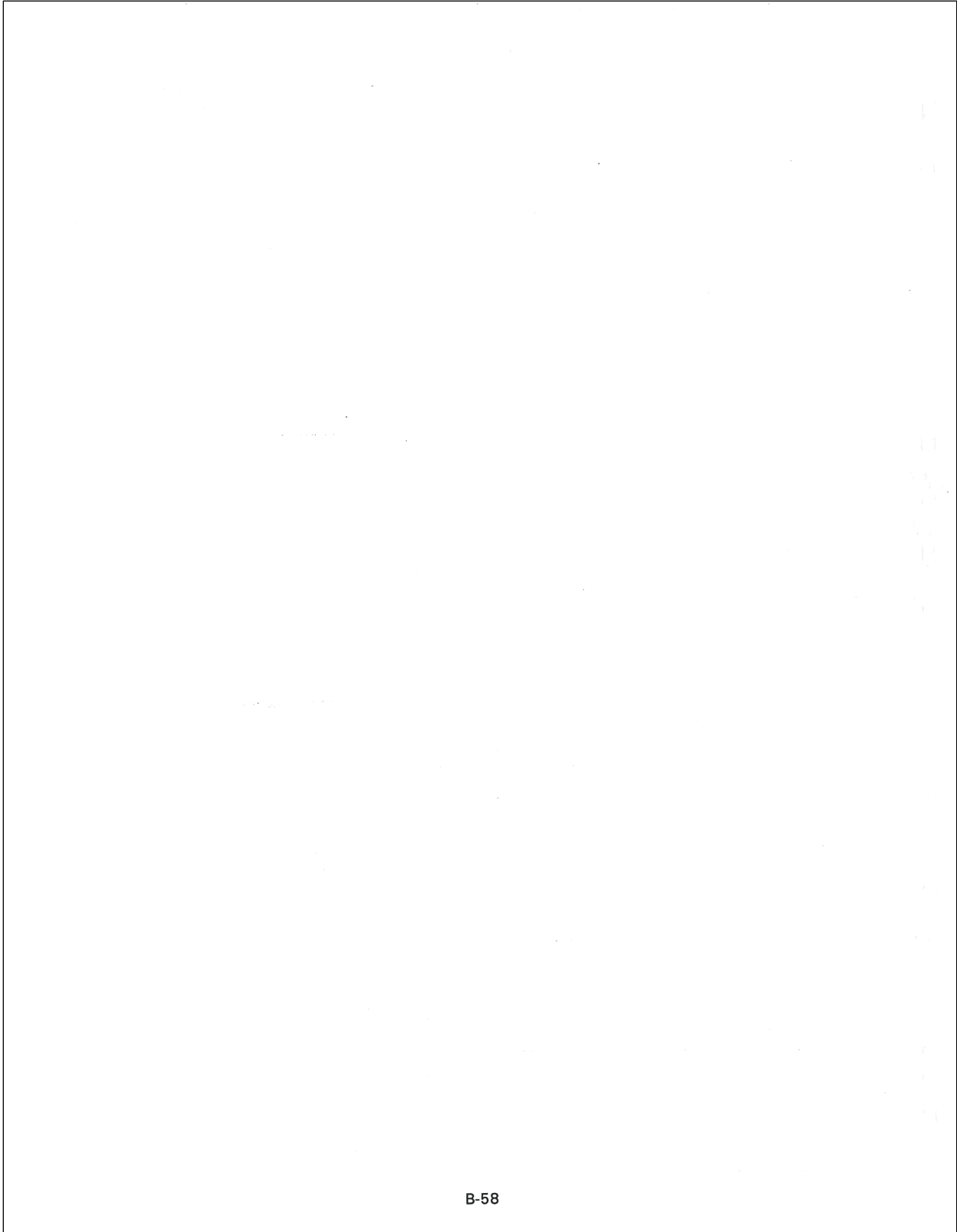
de HAVILLAND
DASH 8

General Arrangement

B-56

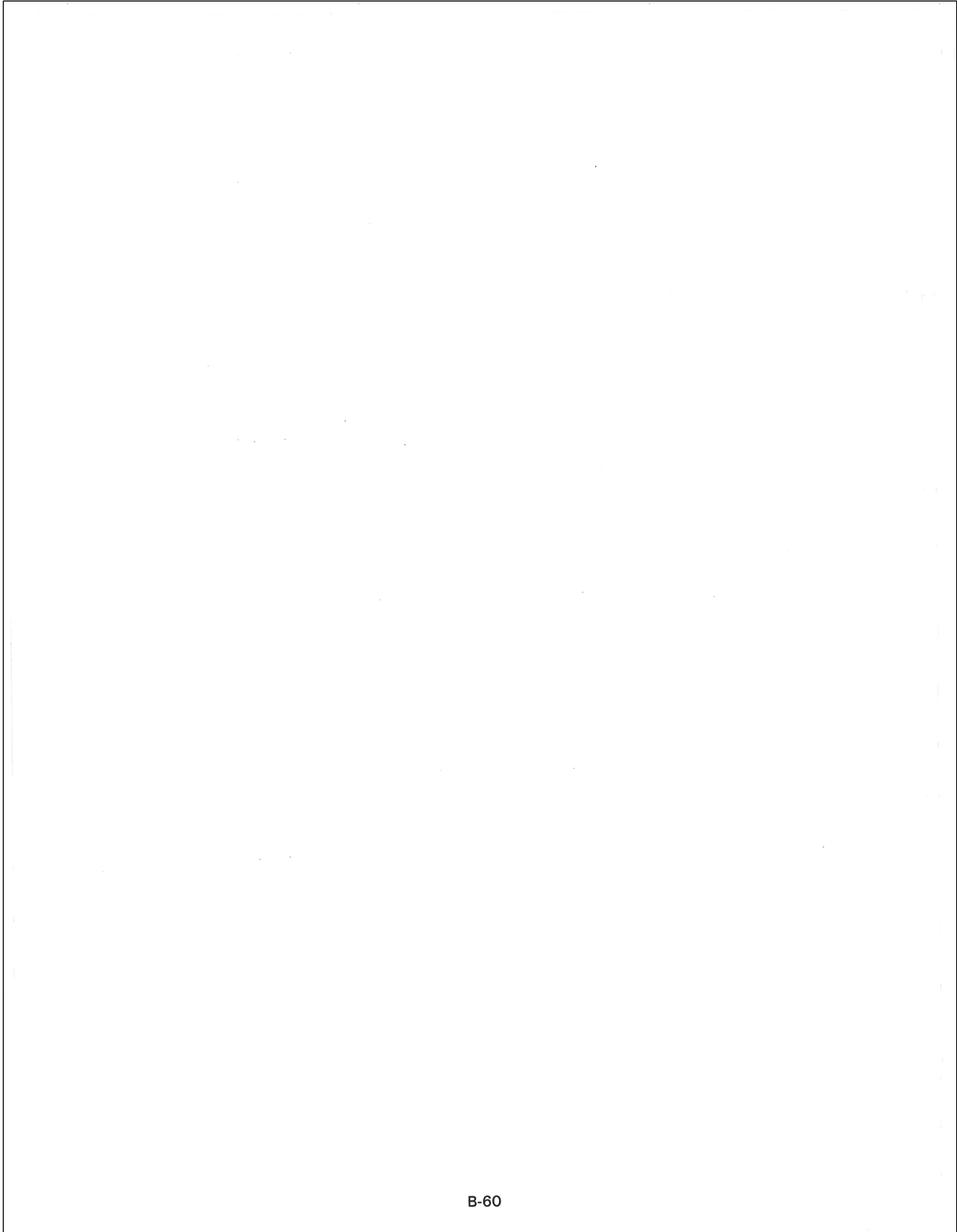






**PHOTO PROCEDURE TO DOCUMENT ROUGHNESS
OF FAILED FLUID**

B-59



B-60

APPENDIX B - PROCEDURE FOR CONDUCTING TESTS ON JET AIRCRAFT

PROCEDURE FOR PHOTOS OF ROUGHNESS ON AIRCRAFT WING

EQUIPMENT:

- Quarters (American)
- Single, Double, Triple
- Scale ?
- Camera with data back/macro lens
- Spray paint (textured)
- Film, Fuji 800

PROCEDURE:

- Determine point of initial failure on wing.
- This becomes point 1.
- Photograph coin #1 (number and wing name is indicated on coin) at the position of initial failure

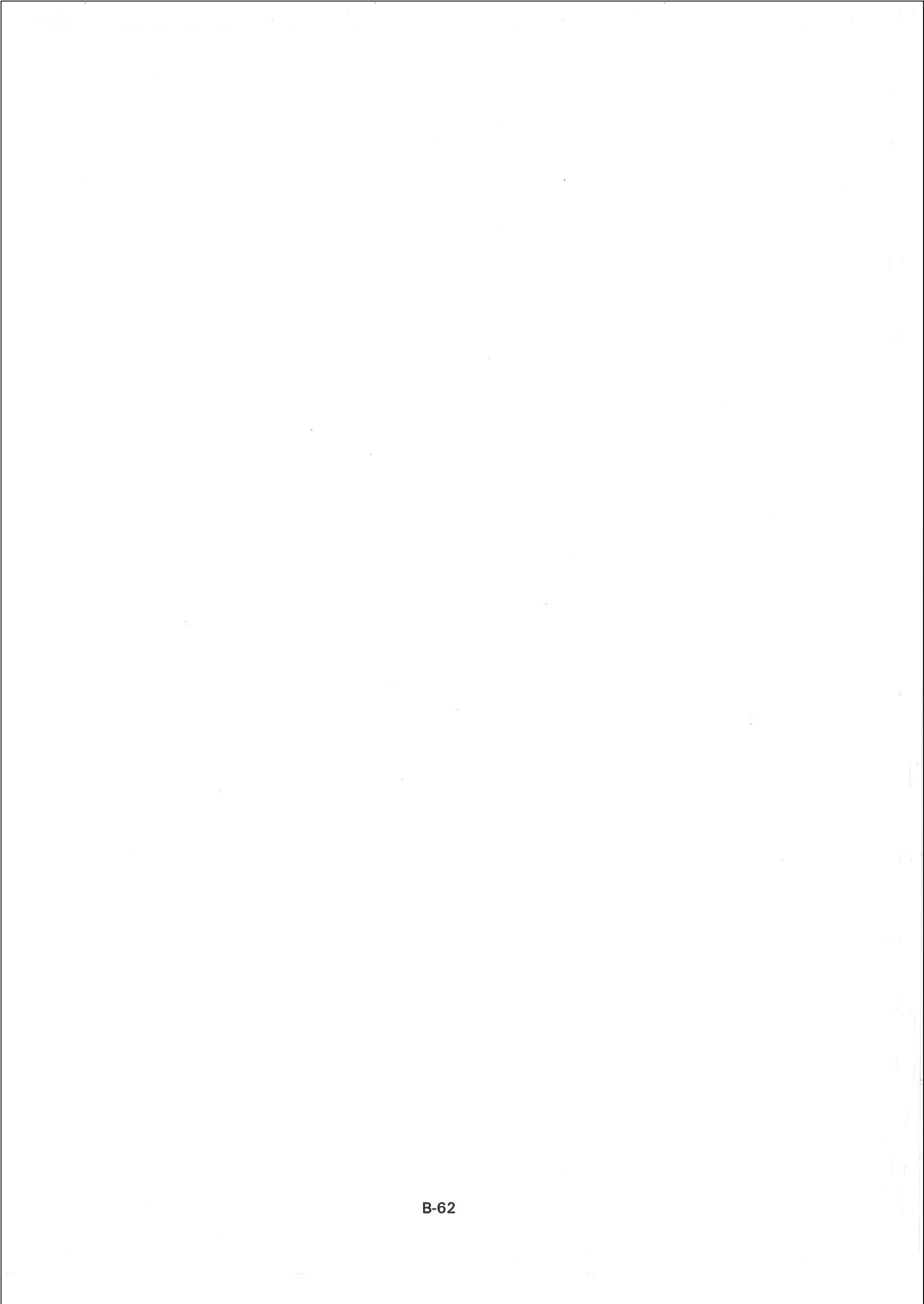
Three photos per location:

1. Overall location of coin relative to failure and rest of wing.
2. Macro profile of crystal's to determine crystal shape and size relative to coin.
3. Macro plan shot to determine roughness and texture of crystal's relative to coin.

Repeat this procedure at two predetermined points on the wing (fluid sampling point #4, #6).

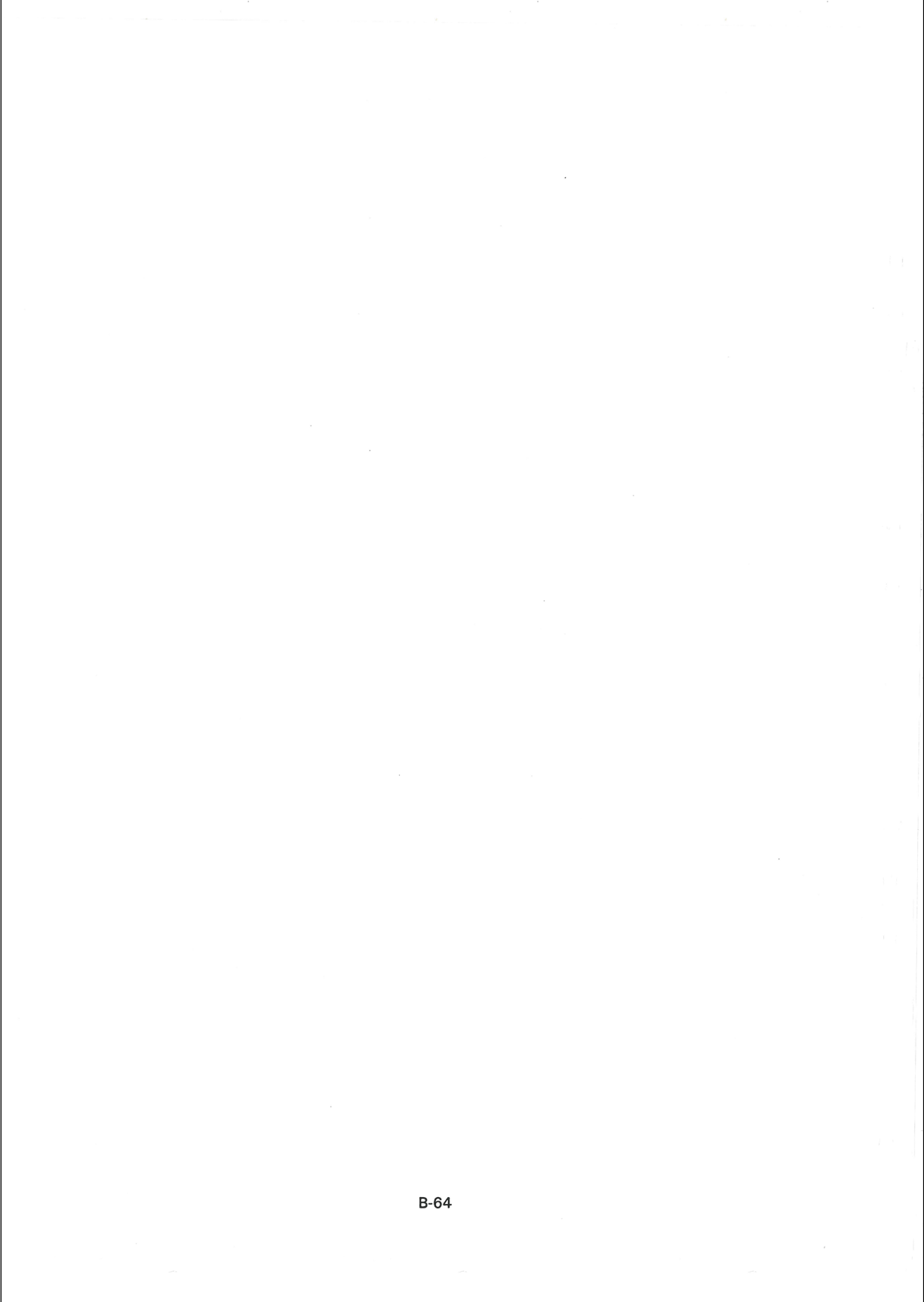
Repeat this procedure with the scale included in the photos?

This procedure is to be carried out on both wings repeatedly until the wing is considered failed by T6.



B-62

RVSI SENSOR PROCEDURE



B-64

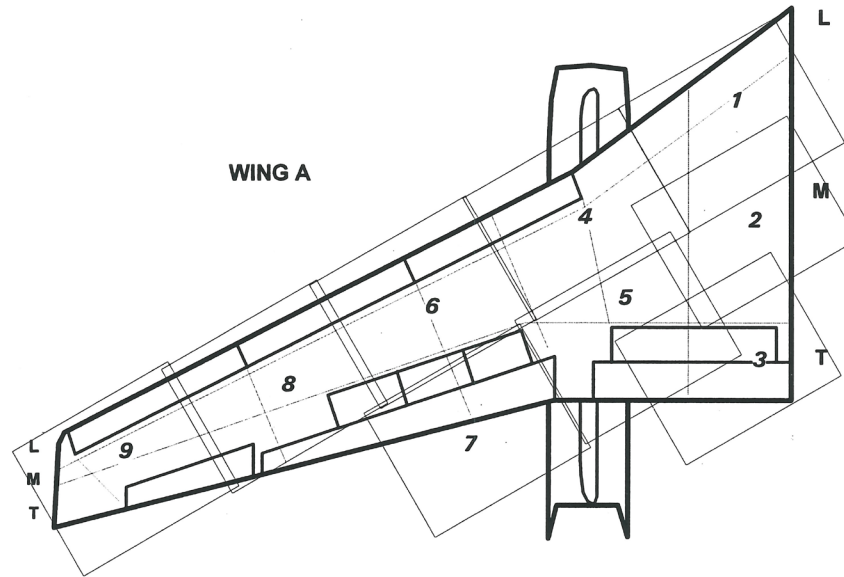
APPENDIX B - RVSI SENSOR PROCEDURE

RVSI SENSOR PROCEDURE

Test Procedure and Equipment

- At initial application of Type I fluid the RVSI operator will take an image of the aircraft's tail identification numbers in order to determine fluid holdover time.
- Use a grid structure such as in the diagram to take images of failure. Take four images across base of wing overlapping each frame. As you progress towards the wingtip less shots are needed across the width of the wing. ** Try to get some identifying object in each frame so as to be able to easily identify location at a later date. **
- Number of images taken are as follows. Every fifteen minutes one entire series of images covering the wing should be performed.
- At end of the test procedure the tail numbers will be imaged again in order to show that all previous shots are associated with that particular aircraft.

FIGURE
BREAKDOWN OF B-737-200 FOR RVSI ID-1 IMAGING

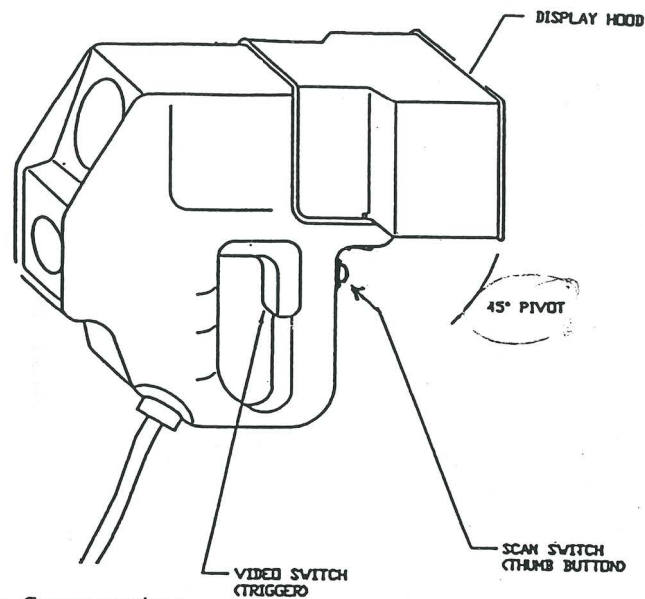


B-66



cm1338\report\full_scl\rvsl-737.drw

Fig - 2 ID-1H SENSOR MODULE A HAND HELD VIDEO SCANNING UNIT.



Sensor Module Components:

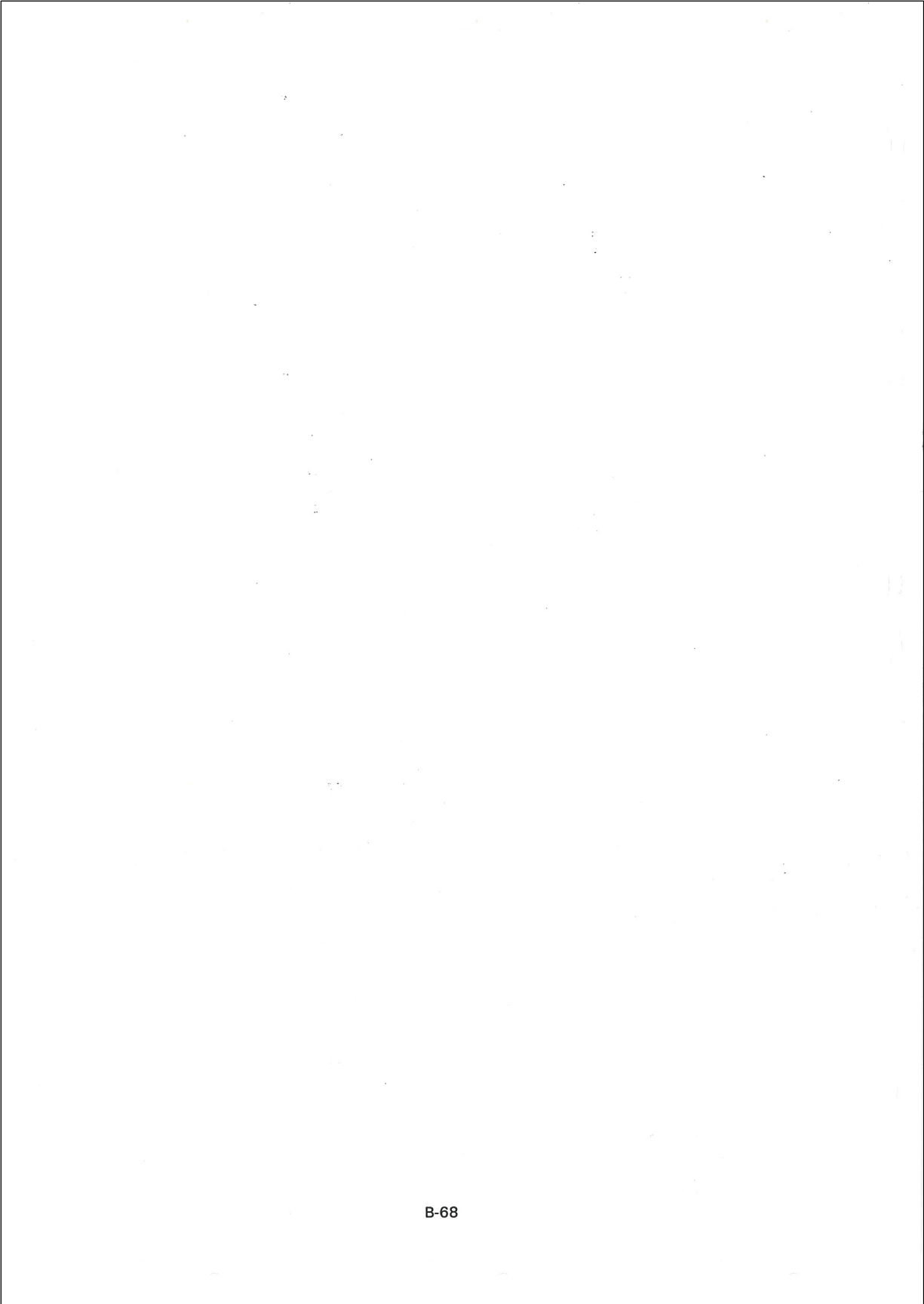
- Video Switch (trigger)
- Scan Switch
- Adjustable Display Screen and Hood

Pulling the video trigger will enable the viewer to see a real time video and record the area of the aircraft being checked. The display screen hood is adjustable for operating at various heights. *PIVOTS FOR COMFORTABLE VIEWING*

When taking a digitally enhanced image, Press and release the scan button. First a black and white still image will appear; then an enhanced image appears. Enhanced images are:

- Green indicates no contamination
- White indicates contamination
- Black means that the scanned object is out of range. This will give a range error message on the monitor.

Reinitiate the next video scan by depressing the scan button.



B-68

APPENDIX C

PROCEDURES FOR CONDUCTING TESTS ON PROPELLER AIRCRAFT

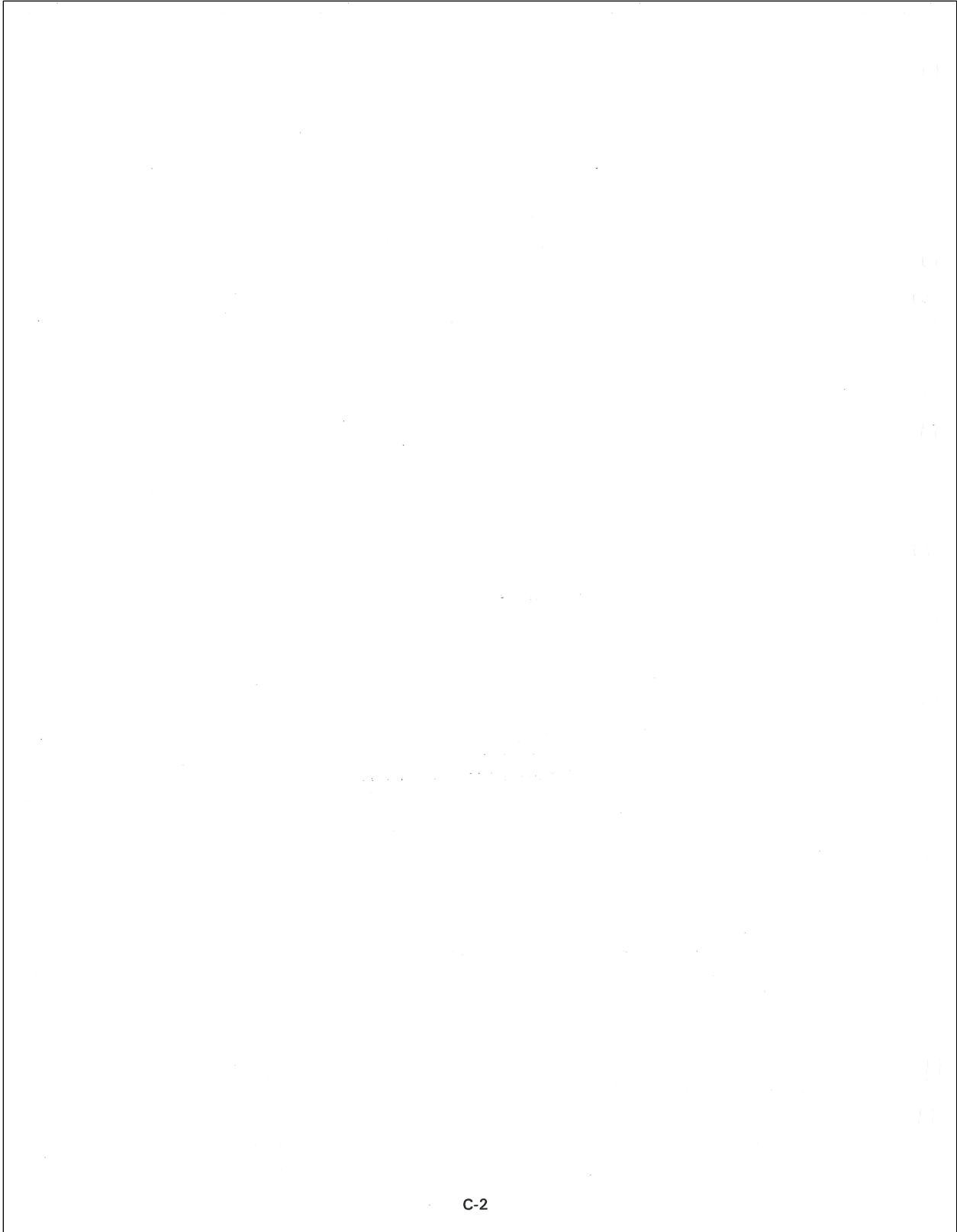
CM1338.001

**PROCEDURE FOR CONDUCTING TESTS
ON PROPELLER AIRCRAFT 1996/97**

APS Aviation Inc.

February 17, 1997
Version 2.1

C-1



PROCEDURE FOR CONDUCTING TESTS ON PROPELLER AIRCRAFT 1996/97

Objective

The pertinent objective of these tests is to observe and record the impact that prop wash over the top of the wing has on the film of deicing fluid, and on patterns of failure on those wings. The ATR42 and DASH 8 aircraft are planned for these tests. Further reference on procedures for these tests can be found in the document prepared for full-scale testing.

Safety Considerations

The objective by definition can only be satisfied by operating the engines and propellers. Turning propeller blades are a well recognized danger in ramp operations, and operators of propeller aircraft in general have strict procedures to ensure personnel are kept well away from danger zones during propeller operation.

Tests involving personnel not trained and experienced in ramp operations must take particular care to ensure safety of personnel.

Additional safety awareness issues are contained in the simultaneous aircraft versus plate testing procedure.

To that end a two phase test program is proposed specifically for propeller aircraft with the intent to minimize test personnel exposure to this particular hazard.

Phase One Tests (*No Precipitation*)

The first phase of the program examines the impact of prop wash on the film of deicing fluid, and does this by measuring thickness on the wing during periods without precipitation. Tests conducted in Winnipeg would also include, Phase II tests (see below) on the same occasion.

Phase Two Tests (*No Precipitation*)

The second phase of the test program examines patterns of failure on the wing of a propeller aircraft. The procedure for these tests is based on the test procedure for full-scale tests and the following sequence of events for turboprops:

1. Apply the test fluids on wing with engine shut down. Simultaneously,

CM1338\procedur\turbopro\v2-2.rpt
Version 2.2
February 17, 1997

PROCEDURE FOR CONDUCTING TESTS ON PROPELLER AIRCRAFT 1996/97

initiate a fluid test on flat plates on a stand situated outside the danger zone and clear of influence of the propeller airstream. Move all personnel back away from the aircraft.

2. Start the engine, advance the throttle to operating speed with propeller blades in normal pitch used for taxiing. The operational expertise and procedures of the operator will be the rule in this phase of the test. Allow the engines to continue running until the plate on the test stand has failed, then shut down the engines. This may be varied to trigger engine shut down upon plate failure at the 1 inch line, or other rule as may be determined during actual testing.
3. Move access ladders to the wing edge to allow examination of the surface for fluid failure, and continue monitoring throughout remaining progress of fluid failure. Collect fluid samples as indicated in Attachment V.
4. Simultaneous tests on the opposite wing could be considered, as well as re-positioning the aircraft to examine impact of tail into the wind and cross-wind.

Sensor Considerations

Use of an area scanning sensor mounted in a location allowing viewing of the wing during engine running would be a possible alternative. The current plan outlooks use of a SPAR Sensor during the second half of the season, at Toronto. As this coincides with planned tests on the DASH 8 aircraft, consideration will be given to the possibility of employing this sensor to monitor the wing condition during engine operation.

Test Plan

Attachment I and IA provides a list of tests to be conducted under conditions without and with precipitation. The conditions required for the tests are listed. For tests with precipitation anticipated outside Montreal, the following plan will be followed:

- 1) Monitor forecast (APS);
- 2) If forecast calls for freezing precipitation with an accumulation greater than 5 cm, then send an alert to APS and DND personnel;

CM1338\procedur\turbopro\v2-2.rpt
Version 2.2
February 17, 1997

PROCEDURE FOR CONDUCTING TESTS ON PROPELLER AIRCRAFT 1996/97

- 3) Arrange travel for APS coordinator 12 to 36 hours prior to precipitation;
- 4) Arrange meeting between DND and APS coordinator at YWG 10 to 24 hours prior to precipitation;
- 5) APS coordinator to arrange pre-setup with DND assistance prior to precipitation; and
- 6) Arrange travel for two other APS personnel to arrive 5 to 20 hours prior to precipitation.

Equipment/Personnel

Test equipment required for the tests is provided in Attachment II and IIA. A description of the responsibilities and duties of the personnel (four required for phase I) is provided in Attachment III. Attachment IIIA provides guidance for personnel assigned to the full-scale precipitation tests with turboprops.

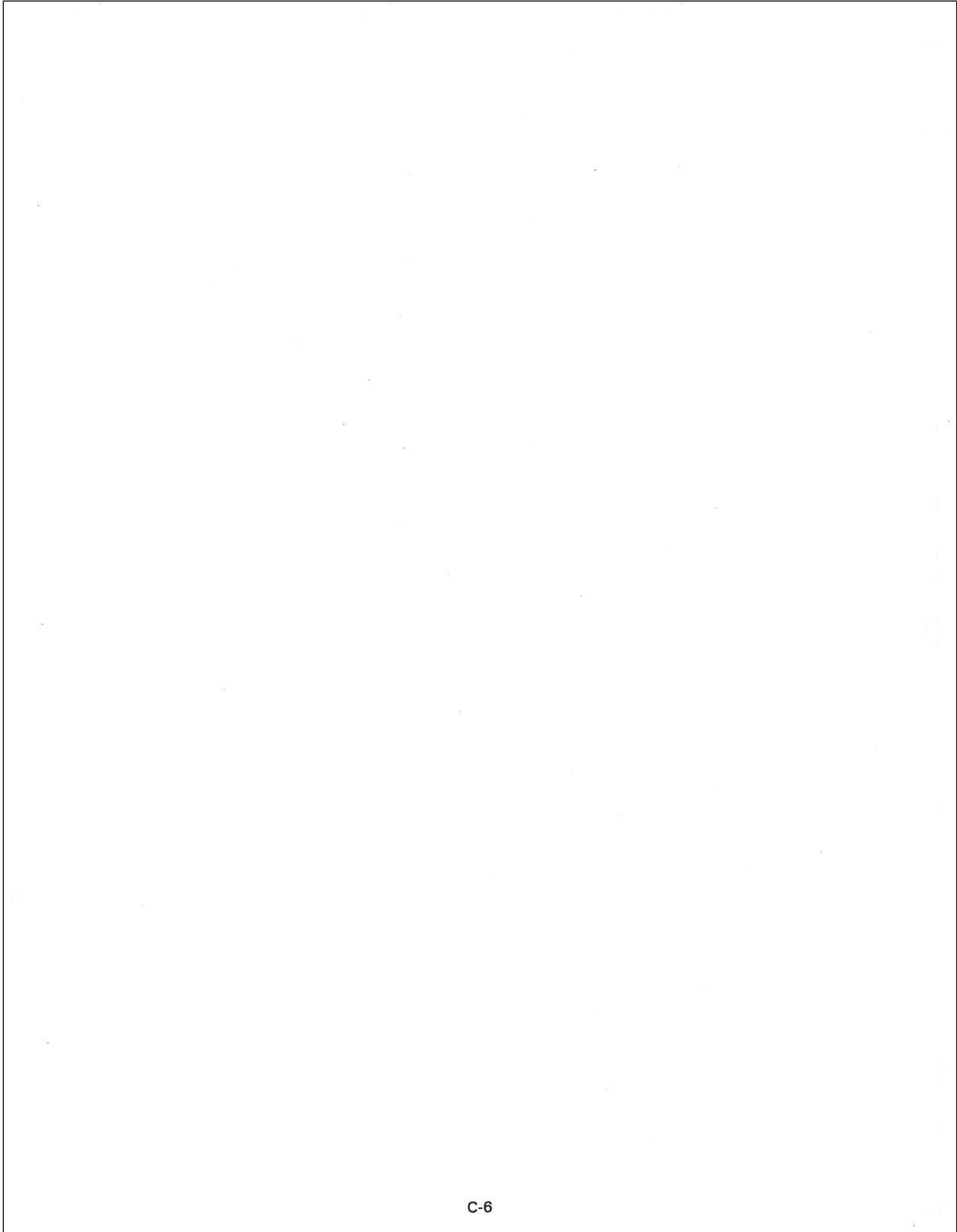
Data Forms

The data forms for the thickness tests (phase I) are listed below:

- | | | | |
|---|-----------|--------------------------------------|-----|
| ● | Figure 3 | General Data Form (every test) | T6 |
| ● | Figure 3a | General Data Form (once per session) | T6 |
| ● | Figure 6 | Fluid Thickness Data Form (wing) | TH2 |
| ● | Att. VI | Fluid Thickness Data Form (plate) | V1 |

The data forms for the turboprop precipitation tests phase II are included in the full-scale test procedure.

CM1338\procedur\turbopro\v2-2.rpt
Version 2.2
February 17, 1997



C-6

ATTACHMENT I
**TEST PLAN FOR
 TURBOPROP AIRCRAFT THICKNESS TESTS**

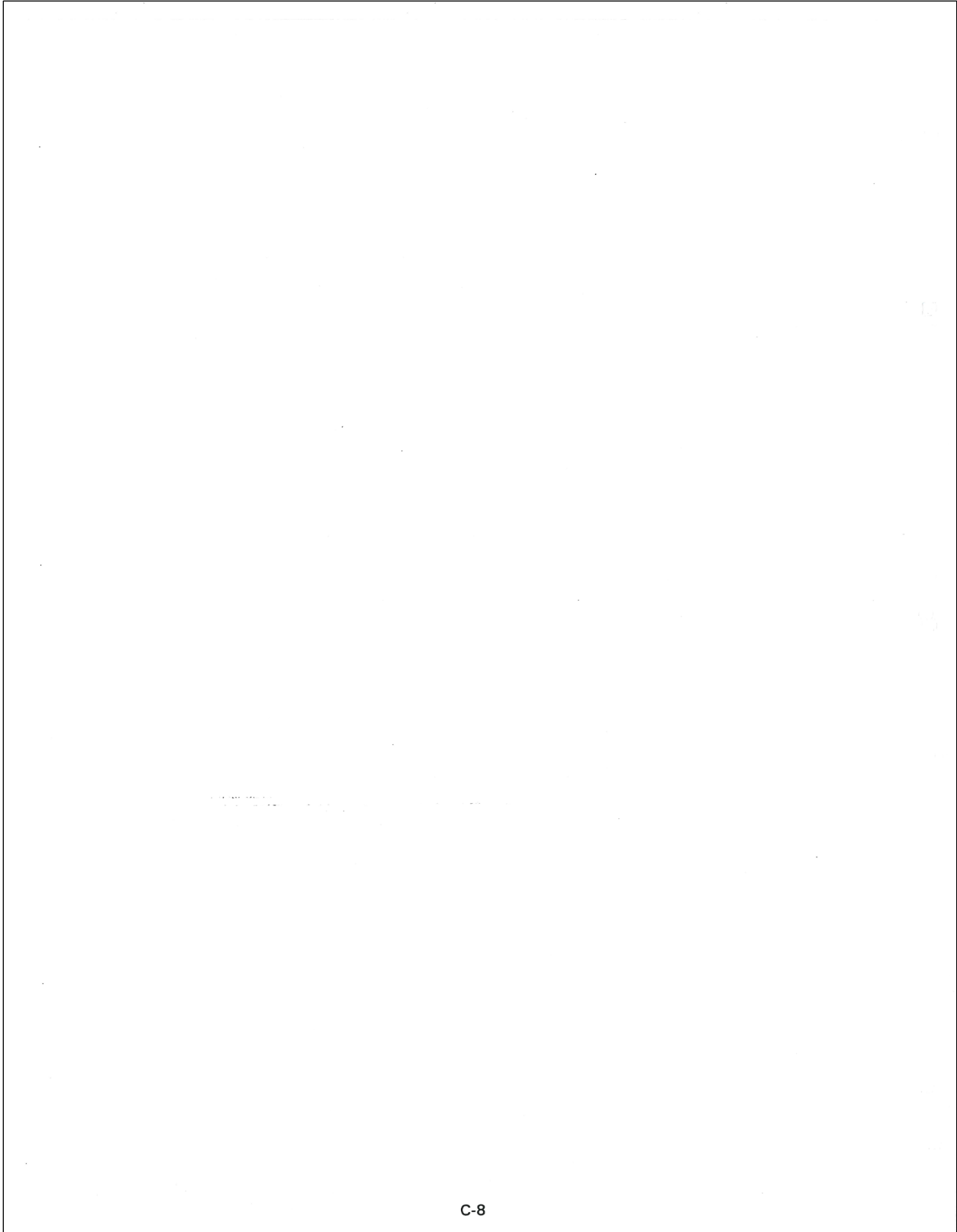
NO PRECIPITATION

OCCASION	RUN #	FLUID TYPE	PROPELLERS ON / OFF
1	1	I	Off
1	2	I	On
2	3	I / IV	Off
2	4	I / IV	On

Conditions Required: Temperature 0 to -10°C
 Winds less than 20 km/hr
 No precipitation, daylight preferred
 Overcast sky preferred

Aircraft: ATR-42 on occasion 1 and 2, and DHC-8 on occasion 3 and 4

Location: Dorval, Toronto or Winnipeg

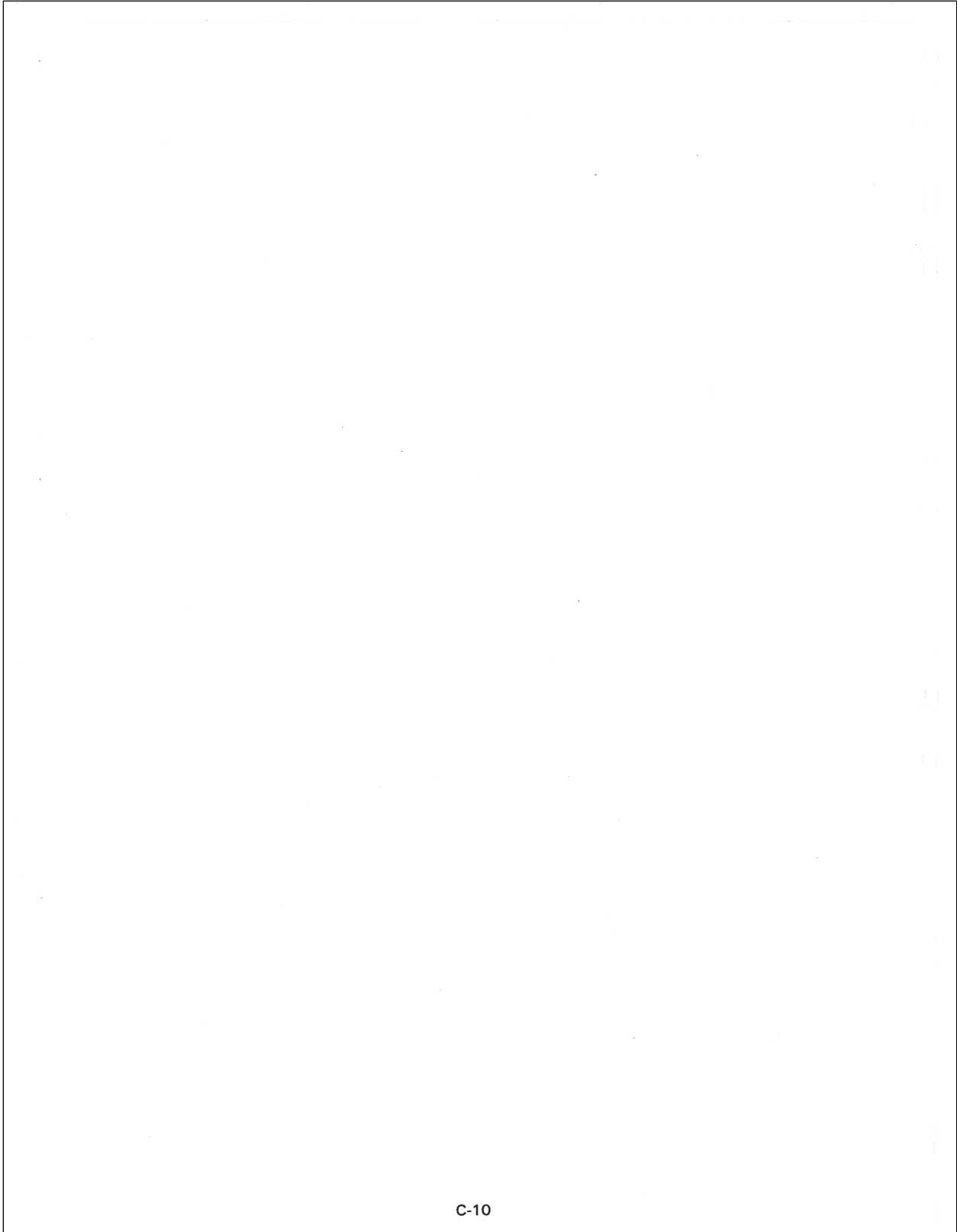


C-8

ATTACHMENT IA
**TEST PLAN FOR
 TURBOPROP AIRCRAFT vs PLATE TESTS**

WITH PRECIPITATION

RUN #	FLUID TYPE	A/C ORIENTATION
1	I	Tail
2	I	Tail
3	I	Cross
4	I	Cross
5	I	Head
6	I	Head



C-10

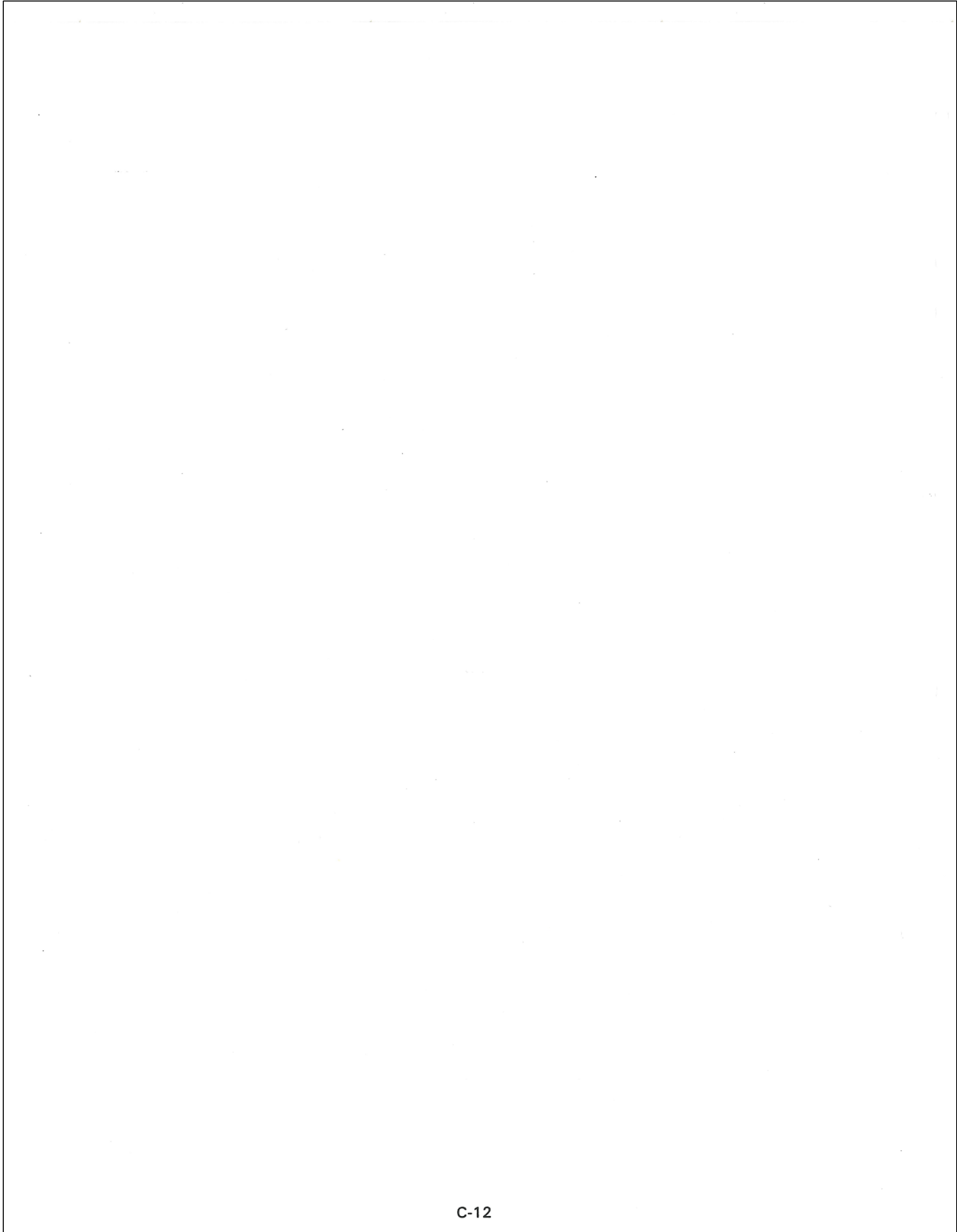
ATTACHMENT II
 TURBOPROP AIRCRAFT THICKNESS TESTS
 TEST EQUIPMENT CHECKLIST

NO PRECIPITATION

TASK
Logistics for Every Test
Passes / Escort
Rent Van
Call Personnel (JM/PD/JD/MH)
Advise Airlines (Personnel, A/C Orientation, Equip)
Monitor Forecast
Test Equipment
Stand x 1
Video Camera x 1 + 5 batteries + 1 charger
Thickness Gauges x 4 + extensions + wipers
Data Forms for plates / General
Aircraft Wing Forms
XL 54 Fluid for plates (20L)
Ultra+ Fluid for plates (20L)
Compass x 1
Video cassettes / films
Clipboards
Space pens and pencils
Paper Towels
Rubber squeegee x 1
Stopwatches
Temperature Probe x 1
Rolling Stairs x 2 (tall ones)
Marking kit
Test Procedure x 5
Photo Camera
OTHER TEST EQUIPMENT (1)
XL 54 Fluids for wings (UCAR)
Ultra+ Fluids for wings (UCAR)
Spray vehicle for XL54 x1 (A/L)
Spray vehicle for Ultra+ x1 (A/L)
Test Aircraft (A/L)
Fluid Collection Facilities
Airline Personnel

(1) To be provided by others

Note: Nighttime tests would require additional equipment (lights, generators, stands, etc.)



C-12

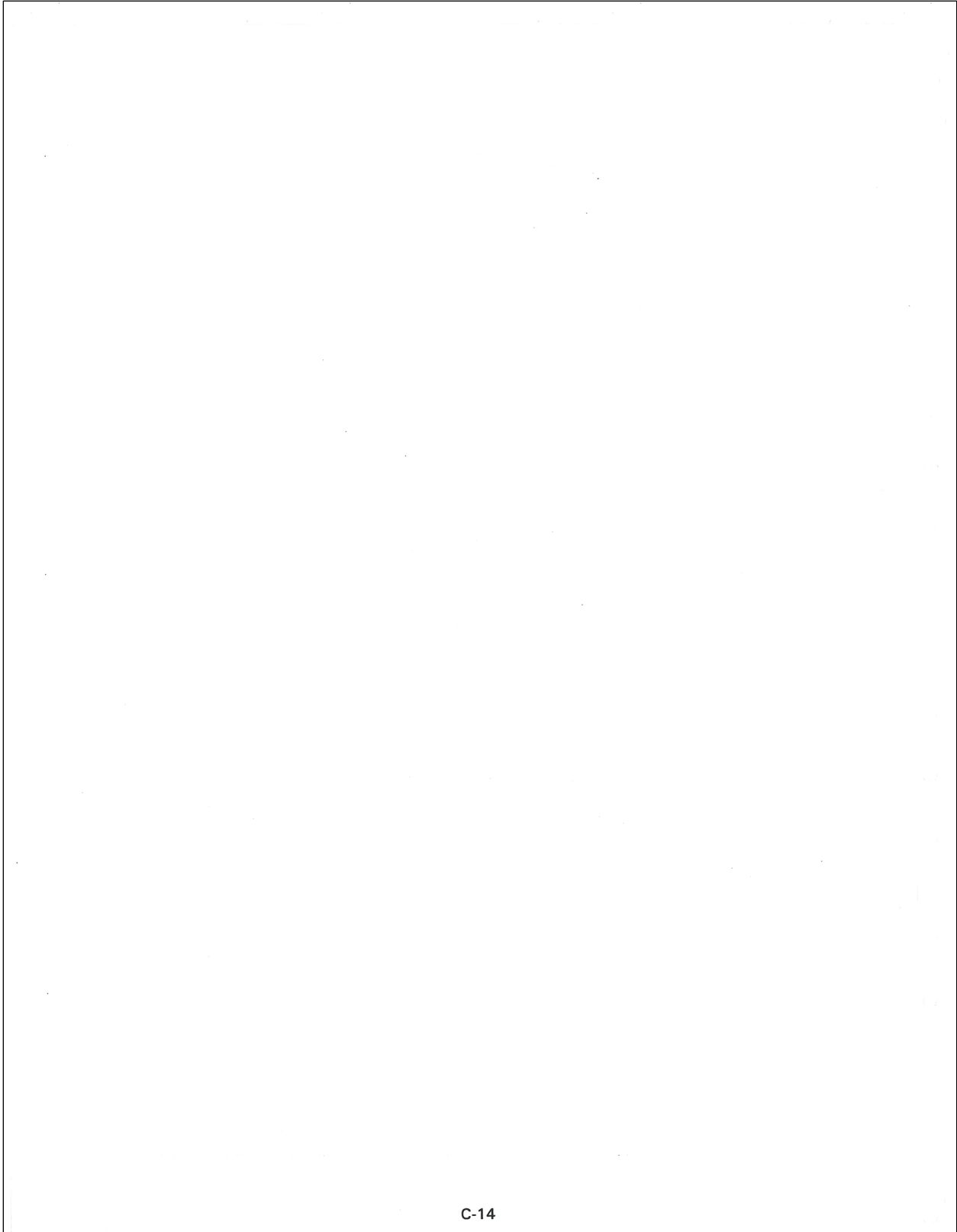
ATTACHMENT IIA
 TURBOPROP AIRCRAFT vs PLATE TESTS
TEST EQUIPMENT CHECKLIST - TURBOPROP

WITH PRECIPITATION

TASK	Resp.	Status
Logistics for Every Test		
Passes / Escort		
Rent Van		
Call Personnel (PD, JD, MH, NB, SF)		
Advise Airlines (Personnel, A/C Orientation, Equip)		
Monitor Forecast		
Call potential participants		
Test Equipment		
Portable Stand with plates		
Weigh Scale x 1		
Video Cameras x 1 + 3 batteries + 1 charger (JD's)		
Thickness Gauge x 2 + extensions + wipers		
Data Forms for plates and general		
Aircraft Wing Forms		
XL 54 Fluid for plates (10L)		
Plate Pans x 2		
Compass x 1		
Video cassettes / films		
Clipboards		
Space pens and pencils		
Paper Towels		
Rubber squeegees x 1		
Stop watches		
Temperature Probe x 1		
Brixometer x1		
Sampling tools		
Sampling containers		
Tape measure x 4 (2 small, 2 large)		
Duct Tape		
Test procedure x 5		
Photo Camera		
Marking kit		
OTHER TEST EQUIPMENT ⁽¹⁾		
XL 54 Fluids for wings (UCAR)		
Spray vehicle for XL54 x1 (A/L)		
Test Aircraft (A/L)		
Storage Facilities		
Fluid Collection Facilities		
Electrical Power (A/L)		
Airline Personnel		

(1) To be provided by others

File:g/cm1338/procedur/turbopro/CHKL_TB2.XLS
 Printed:19/01/97



C-14

ATTACHMENT III - RESPONSIBILITIES/DUTIES

**ATTACHMENT III
Turboprop Aircraft Thickness Tests
Responsibilities/Duties of Test Personnel
NO PRECIPITATION**

Also refer to the test procedure (Attachment IV) for more detailed tester requirements.

- | | |
|--------------------------|---|
| Video/Plate (V1) | <ul style="list-style-type: none"> - Set-up test stand - Located on ground (Refer to FFTP) - Video aircraft test site and set-up - Assist in thickness measuring on flat plates - Picture to be steady and well lit - Knowledge of test procedures - Video application of all fluids - Photograph plates and wings |
| Overall Coordinator (T6) | <ul style="list-style-type: none"> - Knowledge of test procedures - Responsible for area and people - To aid any personnel - Coordinate actions of APS team and as required airline personnel - Responsible for weather condition observations and forecast, advise tester team - Call personnel to conduct tests - Ensure that there are no objects on the ground which may cause FOD at end of session - Ensure test site is safe, functional and operational at all times - Supervise site personnel during the conduct of tests - Review data forms upon completion of test for completeness and correctness (sign) - Ensure aircraft positioned appropriately - Ensure fluids are available and verify fluids being used for test are correct - Ensure proper documentation of tapes, diskettes, cassettes - Complete general data forms and plate data form - Measure film thickness on plates |

CM1338\procedur\turbopro\v2-2.rpt
Version 2.2
February 17, 1997

ATTACHMENT III - RESPONSIBILITIES/DUTIES

Thickness Observers

TH1

- Mark measurement positions on wing (note any changes on plan)
- Remove markings at end of session
- Measure film thickness
- Set up equipment

TH2

- Assist in marking
- Assist in removing markings at end of session
- Record measurements on data form
- Set up equipment
- Complete and sign data form

CM1338\procedur\turbopro\v2-2.rpt
Version 2.2
February 17, 1997

ATTACHMENT IIIA

**ATTACHMENT IIIA
Turboprop Aircraft and Flat Plate Tests
Responsibilities/Duties of Test Personnel
WITH PRECIPITATION**

Three APS personnel will travel to Winnipeg for tests on the Dash-8 with DND. Refer to full-scale test procedure for detailed responsibilities and duties.

- TP1 Coordinator - Responsibilities will include duties of the following personnel from the full-scale test procedure.
 - T6 - Overall Coordinator
 - T3 - End Coordinator
 - T1 - Meteo/Equipment

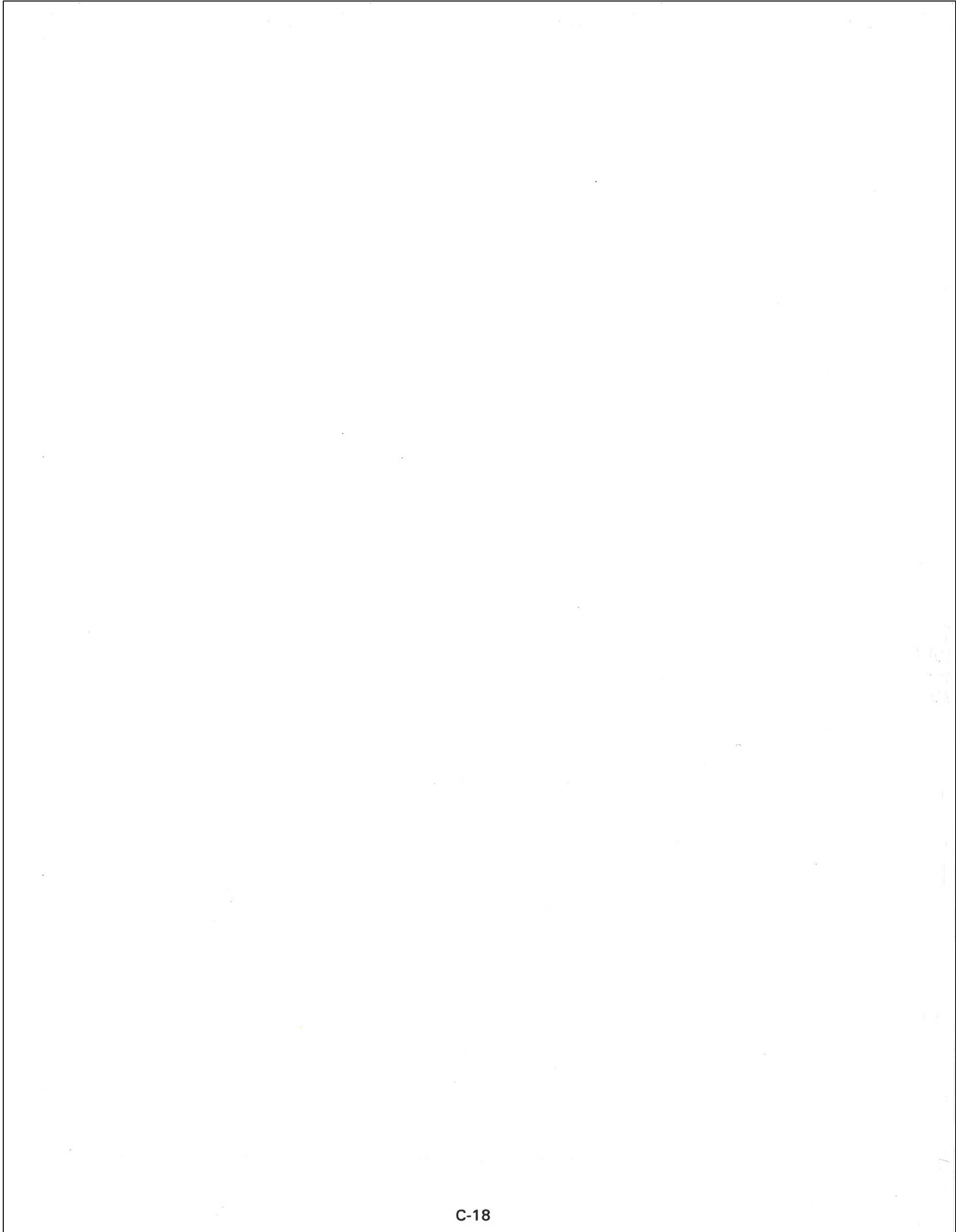
- TP2 Wing Observer - See responsibilities of T2 and T4

- TP3 Sampling - See responsibilities fo T9, T10, T11 and T12

Three additional personnel from DND or students are required for these tests to assist TP1, TP2 and TP3.

Video records of the tests will be taken by an independant firm.

CM1338\procedur\turbopro\v2-2.rpt
Version 2.2
February 17, 1997



C-18

ATTACHMENT IV - TEST PROCEDURE

ATTACHMENT IV
Test Procedure - Thickness Measurements on Turboprops
NO PRECIPITATION**Pre-Test Set-Up**

1. Arrange favourable aircraft orientation (**leading edge, cross-wind or trailing edge into the wind**) and place pylons below wings to delineate sections.
2. Position stairs.
3. Position flat plat test stand into the wind as per the *FPTP*.
4. Position pre-filled test fluid containers, squeegees, and scrapers accordingly. (Type I fluids are stored inside at 20°C; Type IV fluids are applied at ambient temperature).
5. Synchronize all timepieces including video cameras.
6. Ensure airline personnel are aware and knowledgeable of test procedures.
7. Issue data forms in advance of all tests.
8. Place markings on wing at positions in Figure 6.

Execution of Test

1. **Type I Fluid Application**
 - 1.1 Apply Type I fluid (XL 54) with de-icing vehicle to wing
 - 1.2 Simultaneously apply Type I (XL 54) to plates V from containers
2. **Type IV Fluid Application**
 - 2.1 Apply Type I and then Type IV to wing with de-icing vehicle
 - 2.2 Apply Type IV to plate W when application of Type IV to the wing begins.
3. Measure film thickness on the wing and plates after propellers are turned off.
4. A suggested test procedure for measuring fluid thickness is contained in Attachment III of the full-scale test procedure.
5. Coordinator should help pre-position stairs at each chord while thickness is being measured.
6. Video record and photograph the test setup and any irregularities seen in the fluid resulting from the operation of the propellers.

CM1338\procedur\turbopro\v2-2.rpt
Version 2.2
February 17, 1997

ATTACHMENT IV - TEST PROCEDURE

End of Test

The test will be terminated when fluid thickness stabilizes.

Ensure all voice tapes are collected and properly identified.

Ensure data form is completed for end of test and other data.

Post Test

For tests involving Type IV, spray wings with Type I fluid to remove all traces of test fluid.

Remove all tape used as measurement location indicators.

Restore test area to pre-test conditions.

CM1338\procedur\turbopro\v2-2.rpt
Version 2.2
February 17, 1997

**FIGURE 3
GENERAL FORM (EVERY TEST)
(TO BE FILLED IN BY PLATE/WING COORDINATOR)**

DATE: _____ AIRCRAFT TYPE: ATR-42 F-100 B-737 RJ DHC-8
 RUN #: _____ WING: PORT (A) STARBOARD (B)
 DIRECTION OF AIRCRAFT: _____ DEGREES

DRAW DIRECTION OF WIND WRT WING:



<i>1st FLUID APPLICATION</i>	
Actual Start Time: _____ am / pm	Actual End Time: _____ am / pm
Amount of Fluid Sprayed: _____ L / gal	Type of Fluid: _____
<i>2nd FLUID APPLICATION</i>	
Actual Start Time: _____ am / pm	Actual End Time: _____ am / pm
Amount of Fluid Sprayed: _____ L / gal	Type of Fluid: _____

End of Test Time: _____ (hr:min:ss) am/pm

COMMENTS:

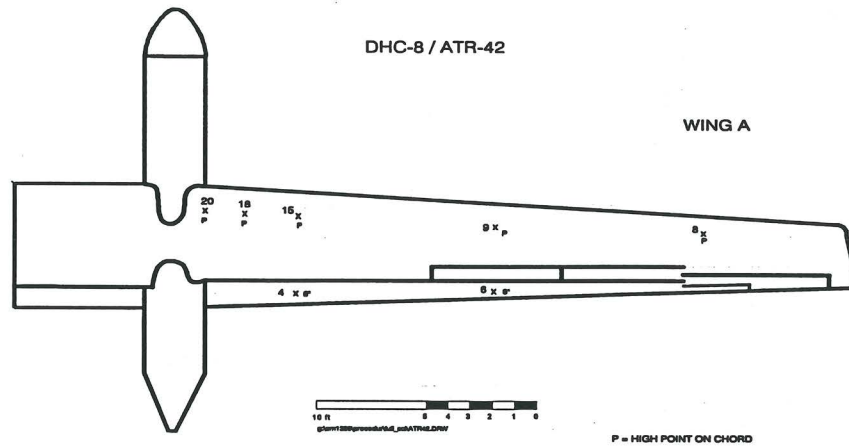
MEASUREMENTS BY: _____

HAND WRITTEN BY: _____

File:g:\cm1338\procedur\full_scl\GFORM3.XLS
 At: GFORM 2
 Printed: 26/02/97

ATTACHMENT V
**TEST PROCEDURE FOR SAMPLING OF FLUIDS - TURBOPROPS
 WITH PRECIPITATION**

- 1) Locate sampling points using a black marker. Each wing has sampling locations as shown in the schematic.
- 2) Take samples at time increments given below.
 Take a sample (> 10 drops) at all locations on that wing.
 Measure film thickness on points 9, 6 at the same time that samples are taken.
- 3) Cover container between each sampling. Record sampling time.
- 4) Leave samples inside, allowing them to warm up. Identify each container with run # and measure brix values on following day with MISCO 10431 Refractometer
- 5) Collect samples of non-contaminated fluid (Type I) from containers and truck.
- 6) Remove markings from aircraft with solvent.



SEQUENCE SAMPLE POSITIONS FOR EACH TEST

- 20- In line with engine, high point on chord
- 18- 1/2 span of prop, high point on chord
- 15- Tip of prop, high point on chord
- 9- Chord with metal, high point on chord
- 8- Near wing tip, high point on chord
- 6- Chord with metal, TE 6" below joint
- 4- Tip of prop, TE 6" below joint

MEASUREMENT TIME

- Props turned off and end of test for Type I.
- Props turned off and end of test for Type I.
- Props turned off and end of test for Type I.
- Props turned off and end of test for Type I.
- Props turned off and end of test for Type I.
- Props turned off and end of test for Type I.
- Props turned off and end of test for Type I.

SAMPLES TAKEN ONCE IN THE EVENING

- S_{p1} . sample of Type I fluid from container.
- S_{t1} . sample of Type I fluid from truck

g:\cm1338\procedu\turboprop\SAMPL_F1.XLS
 At: Procedure
 Printed: 19/01/97

FIGURE 4
DE/ANTI-ICING FORM FOR AIRCRAFT WING

REMEMBER TO SYNCHRONIZE TIME

DATE: _____ RUN NUMBER: _____ VERSION 4.0 Writer 6997

FAILURES CALLED BY: _____

HANDWRITTEN BY: _____

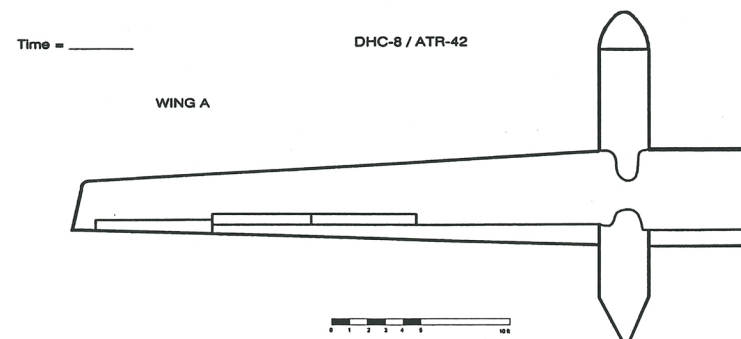
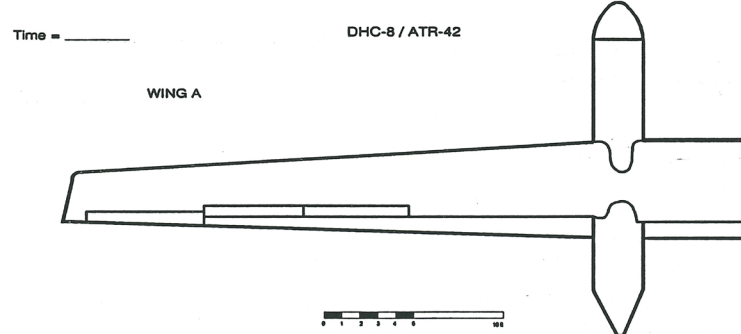
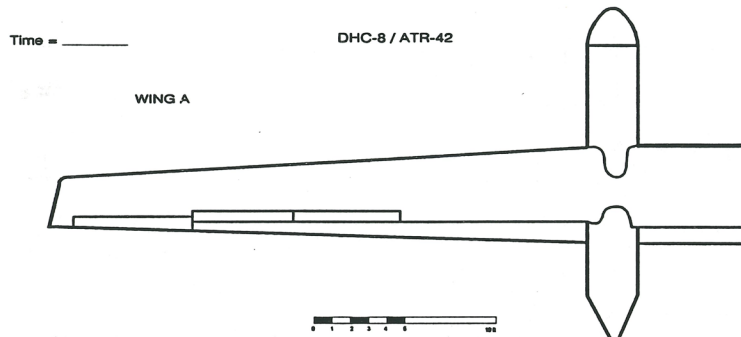
ASSISTED BY: _____

COMMENTS: _____

DRAW FAILURE CONTOURS (hr:min) ACCORDING TO THE PROCEDURE
(Indicate Representative Surface on Drawing)

IMPORTANT EVENTS (hr:min)			
	L.Edge	Mid	T.Edge
1st Failure:	_____	_____	_____
10% :	_____	_____	_____
25% :	_____	_____	_____
75% :	_____	_____	_____
100% :	_____	_____	_____

File: g:\cm1338\procedur\full_scl\Alarm3.drw



Note: To Compare to Flat Plate testing, subtract "Time of Initial Fluid Application".

File: cm1338\procedur\full_scl\Alarm3.drw
At: Wing A Printed: 26/02/97

FIGURE 4
DE/ANTI-ICING FORM FOR AIRCRAFT WING

REMEMBER TO SYNCHRONIZE TIME

DATE: _____ RUN NUMBER: _____

VERSION 4.0 Winter 2007

FAILURES CALLED BY: _____

HANDWRITTEN BY: _____

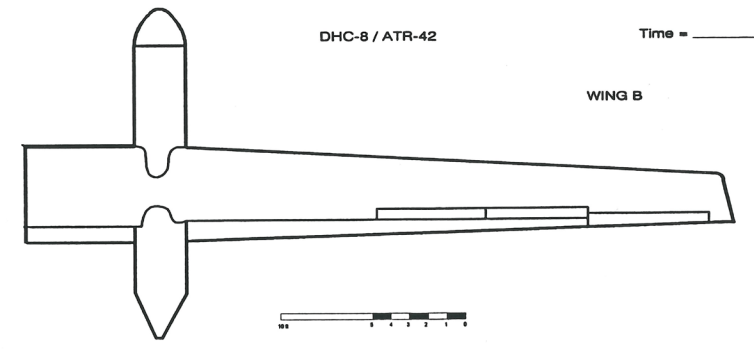
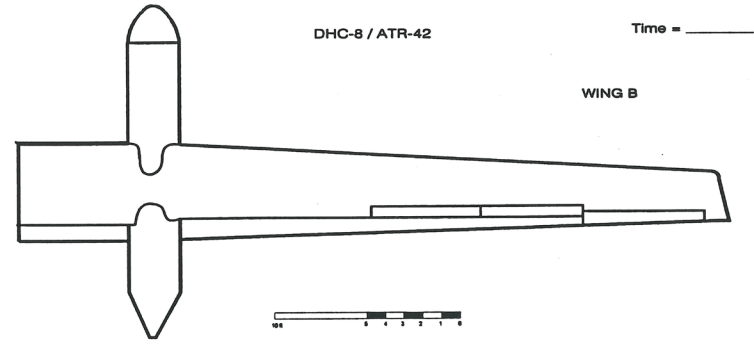
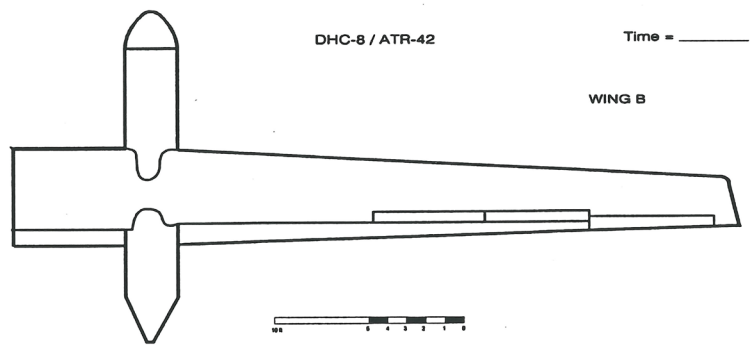
ASSISTED BY: _____

COMMENTS: _____

DRAW FAILURE CONTOURS (hr:min) ACCORDING TO THE PROCEDURE
(Indicate Representative Surface on Drawing)

IMPORTANT EVENTS (hr:min)			
	L.Edge	Mid	T.Edge
1st Failure:	_____	_____	_____
10% :	_____	_____	_____
25% :	_____	_____	_____
75% :	_____	_____	_____
100% :	_____	_____	_____

File: g:\cm1338\proceedur\full_scl\form3.drw



Note: To Compare to Flat Plate testing, submit "Time of Initial Fluid Application".

File: g:\cm1338\proceedur\full_scl\form3.drw
AE Wing B Print: 260297

FIGURE 5A
SAMPLING DATA FORM - TURBOPROPS
WITH PRECIPITATION

RUN #: _____

DATE: _____

- Take clean Type I Fluid samples once in evening from containers and truck.

		1st Wing Sampling	2nd Wing Sampling	3rd Wing Sampling	4th Wing Sampling
Start Time					
End Time					

THICKNESS MEASUREMENTS

Location	After Fluid Application	Gauge	Time	Gauge	Time	Gauge	Time	Gauge	Time	Gauge
9										
6										

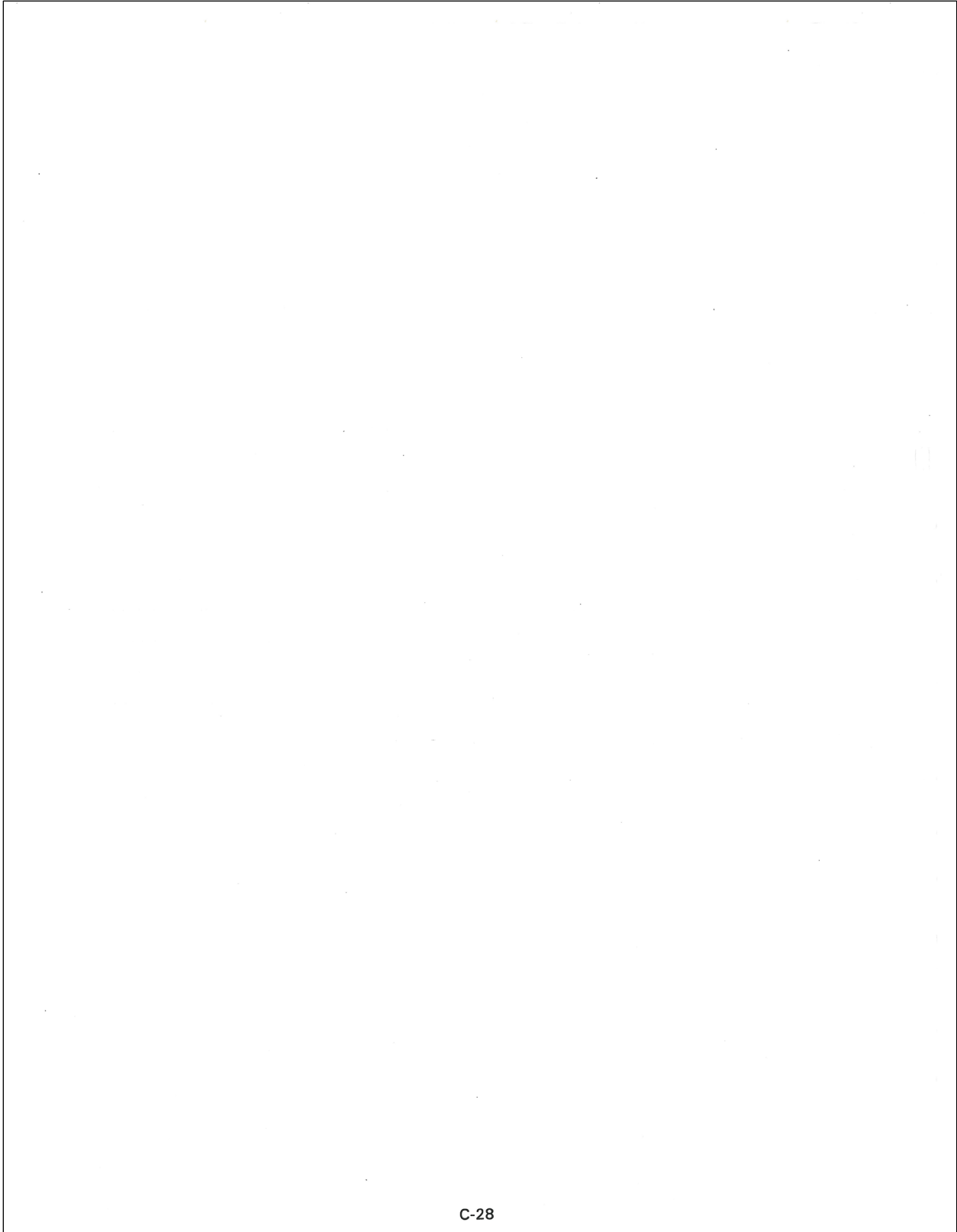
Comments: _____

Sample Taken by: _____

Handwritten by: _____

Approved by: _____

g:\cm1338\procedur\turbopro\fig_5.xls
 At: Sampling
 Printed: 26/02/97



C-28

TABLE 1
END CONDITION DATA FORM

REMEMBER TO SYNCHRONIZE TIME WITH AES - USE REAL TIME VERSION 4.0 Winter 96/97

LOCATION: _____ DATE: _____ RUN #: _____ STAND #: _____

RVSI Series #: _____

CIRCLE SENSOR PLATE: u v w x y z

SENSOR NAME: _____

DIRECTION OF STAND: _____ °

OTHER COMMENTS (Fluid Batch, etc):

C-30

PRINT SIGN

FAILURES CALLED BY : _____

HAND WRITTEN BY : _____

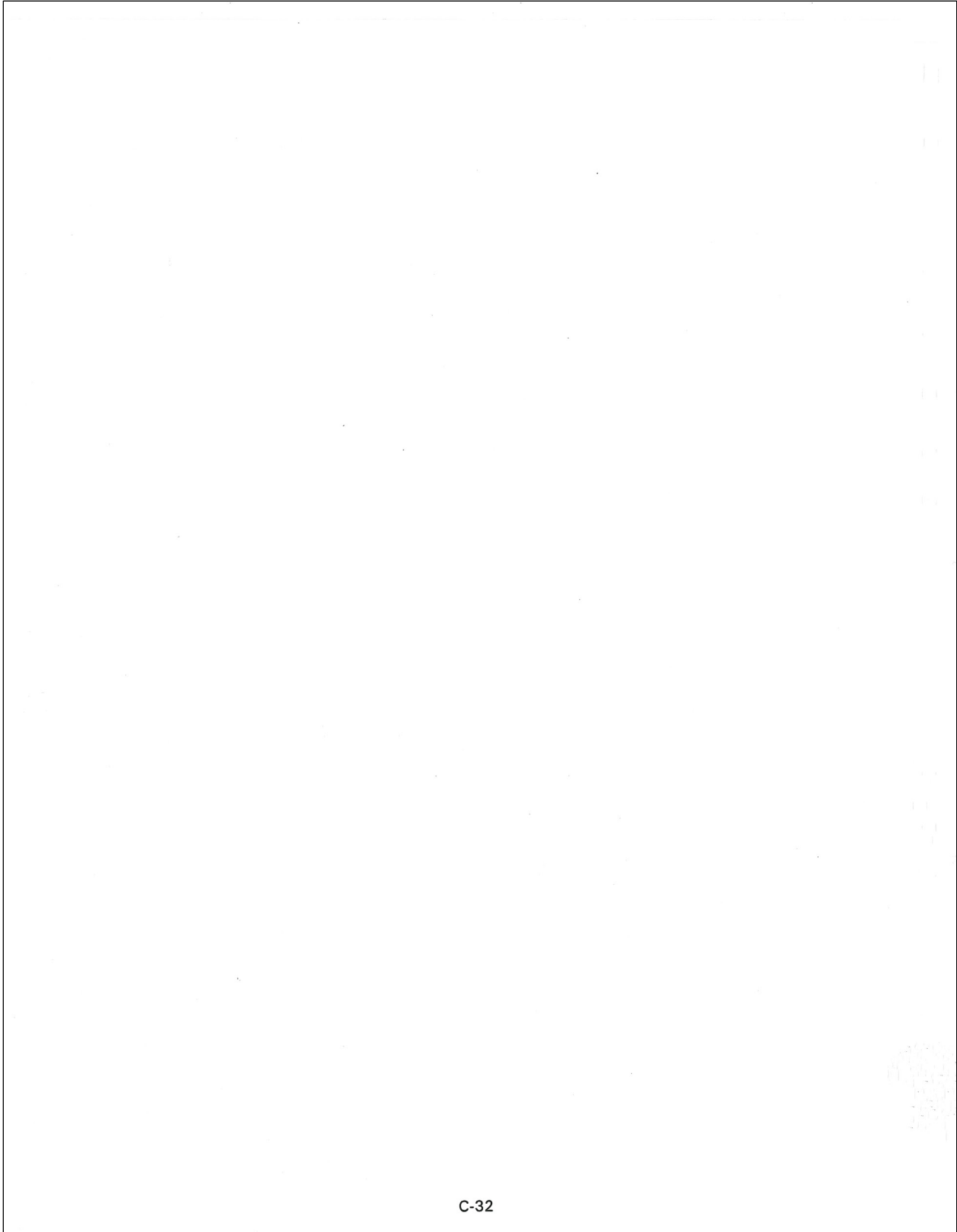
TEST SITE LEADER : _____

*TIME (After Fluid Application) TO FAILURE FOR INDIVIDUAL CROSSHAIRS (hr:min)

Time of Fluid Application: _____ hr:min (U & X) _____ hr:min (V & Y) _____ hr:min (W & Z)

	Plate U			Plate V			Plate W		
FLUID NAME									
B1 B2 B3									
C1 C2 C3									
D1 D2 D3									
E1 E2 E3									
F1 F2 F3									
TIME TO FIRST PLATE FAILURE WITHIN WORK AREA									
CALCULATED FAILURE TIME (MINUTES)									

	Plate X			Plate Y			Plate Z		
FLUID NAME									
B1 B2 B3									
C1 C2 C3									
D1 D2 D3									
E1 E2 E3									
F1 F2 F3									
TIME TO FIRST PLATE FAILURE WITHIN WORK AREA									
CALCULATED FAILURE TIME (MINUTES)									



C-32

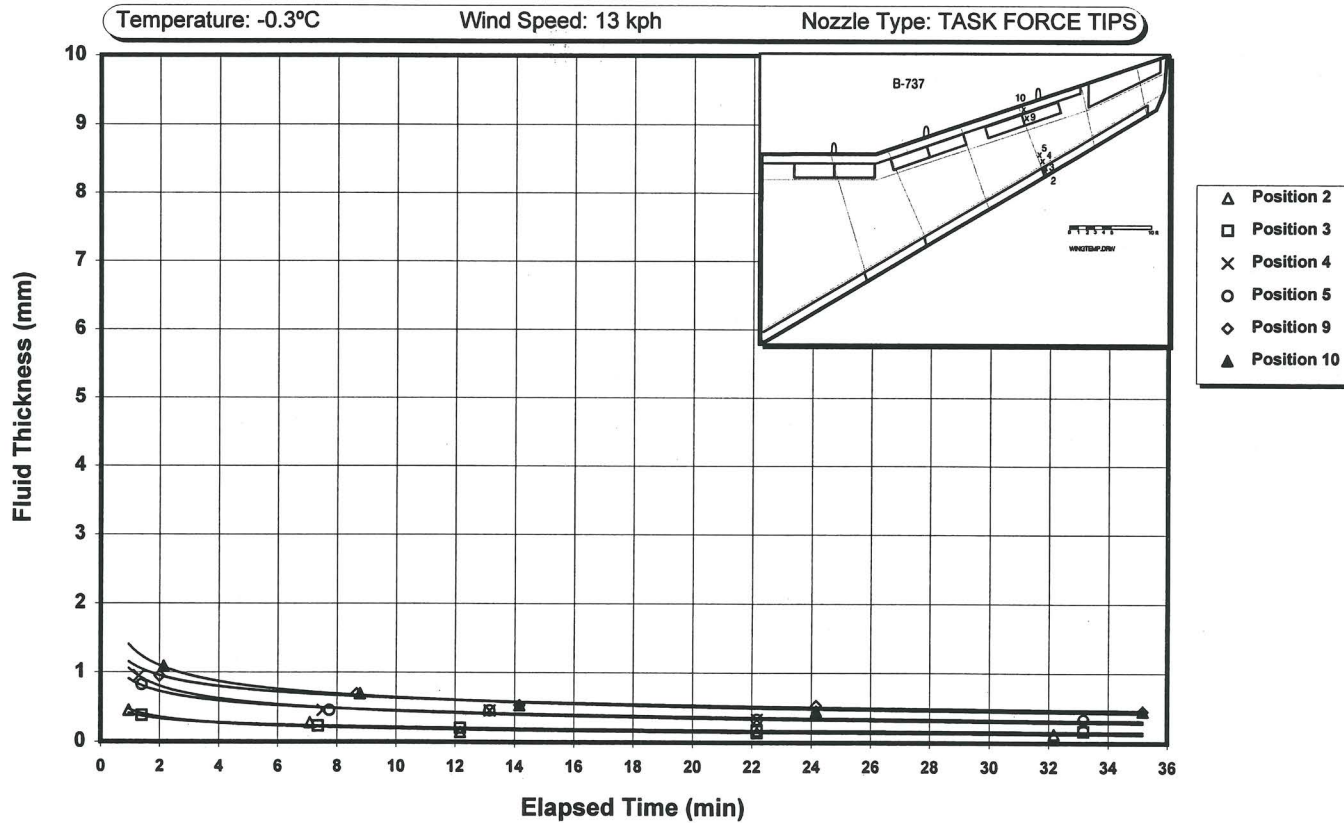
APPENDIX D

FLUID THICKNESS TRIALS ON JET AIRCRAFT

List of Figures in Appendix D

- Figure D.1 Type IV Fluid Thickness Decay at Various Wing Locations; ID # T3
- Figure D.2 Type IV Fluid Thickness Profile on Wing Chord; ID # T3
- Figure D.3 Type IV Fluid Thickness on Wing Plan; ID # T3
- Figure D.4 Type IV Fluid Thickness Decay at Various Wing Locations; ID # T4
- Figure D.5 Type IV Fluid Thickness Profile on Wing Chord; ID # T4
- Figure D.6 Type IV Fluid Thickness on Wing Plan; ID # T4
- Figure D.7 Type IV Fluid Thickness Decay at Various Wing Locations; ID # T5
- Figure D.8 Type IV Fluid Thickness Profile on Wing Chord; ID # T5
- Figure D.9 Type IV Fluid Thickness on Wing Plan; ID # T5
- Figure D.10 Type IV Fluid Thickness Decay at Various Wing Locations; ID # T6
- Figure D.11 Type IV Fluid Thickness Profile on Wing Chord; ID # T6
- Figure D.12 Type IV Fluid Thickness on Wing Plan; ID # T6
- Figure D.13 Type IV Fluid Thickness Decay at Various Wing Locations; ID # T11
- Figure D.14 Type IV Fluid Thickness Profile on Wing Chord; ID # T11
- Figure D.15 Type IV Fluid Thickness on Wing Plan; ID # T11

FIGURE D.1
FLUID THICKNESS DECAY OF VARIOUS WING POSITIONS
B-737, ID# T3 - JANUARY 16, 1997
 1st FLUID: XL54 TYPE I / 25 LITRES
 2nd FLUID: ULTRA TYPE IV / 50 LITRES



D-2

File:g:\cm1338\analysis\thickness\T3_THPRF.XLS
 At: Run 3
 Pfi: 1/14/12/97, 07:14:24

FIGURE D.2
TYPE IV FLUID THICKNESS (STABILIZED) PROFILE - NO PRECIPITATION
 ULTRA+ OVER XL54 ON B-737 WING, ULTRA ON PLATES
 ID# T3 - January 16, 1997

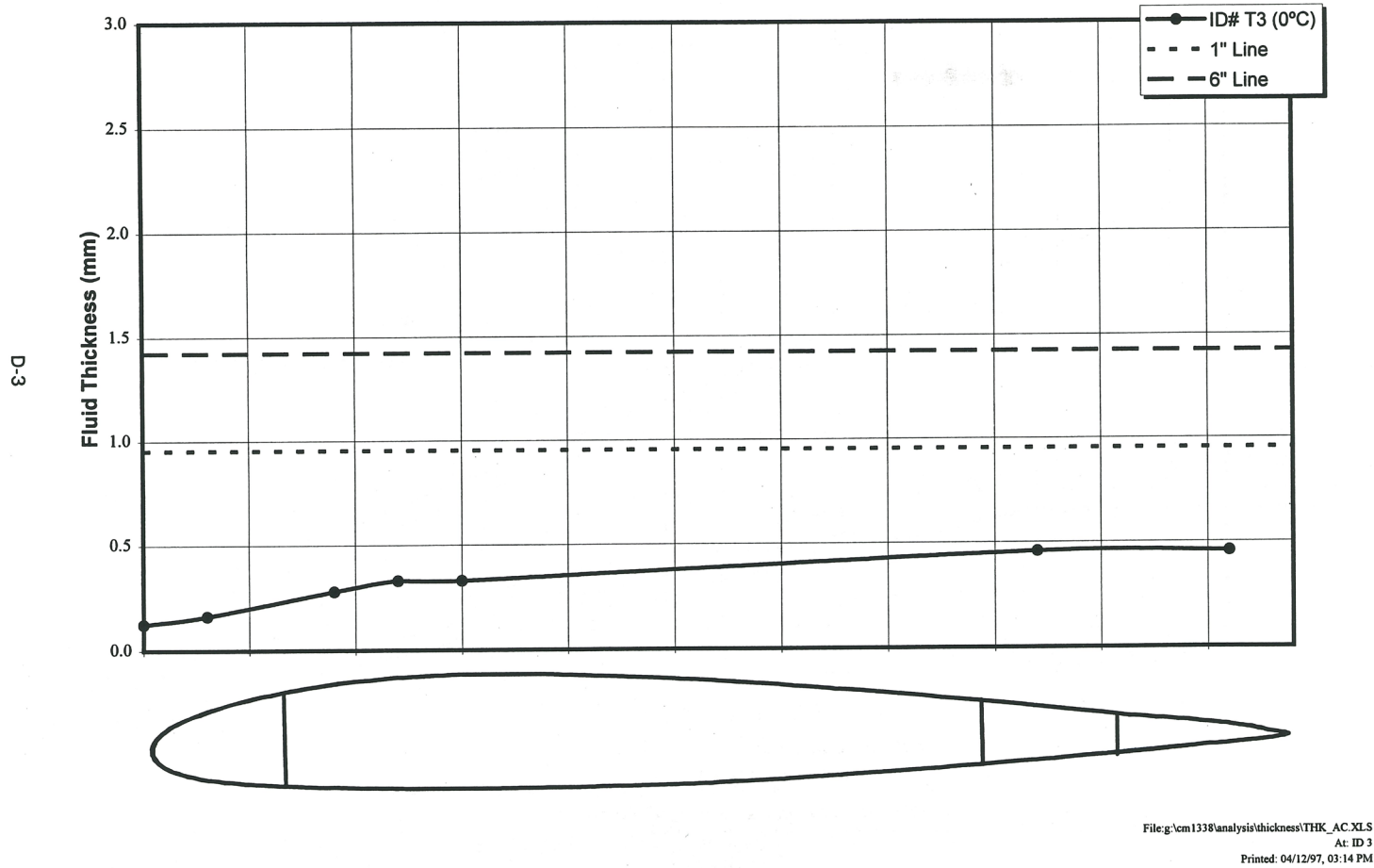


FIGURE D.3
B-737 STABILIZED THICKNESS ON WING PLAN
 ID# T3 - January 16, 1997, Ultra/XL54
 (mm)

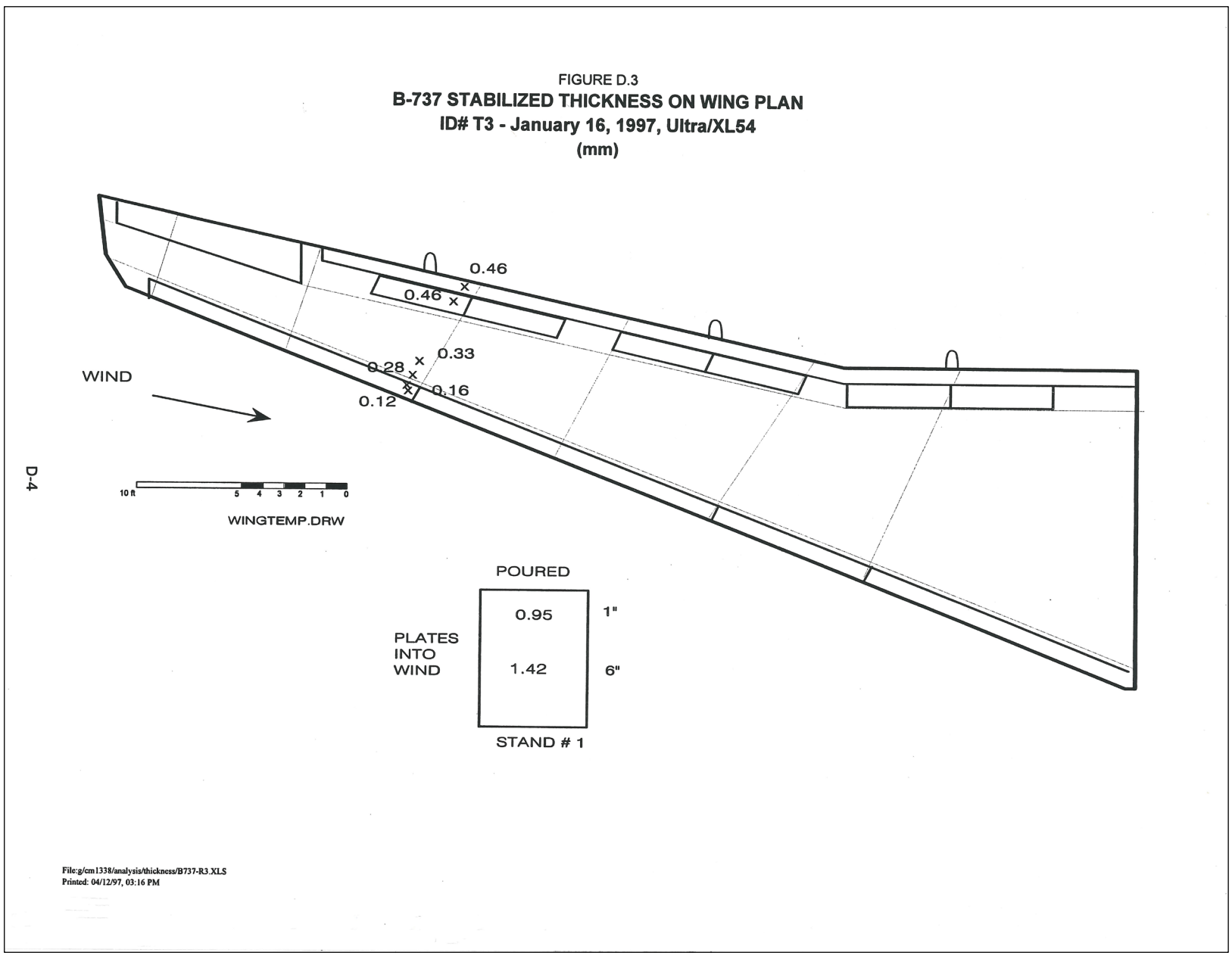
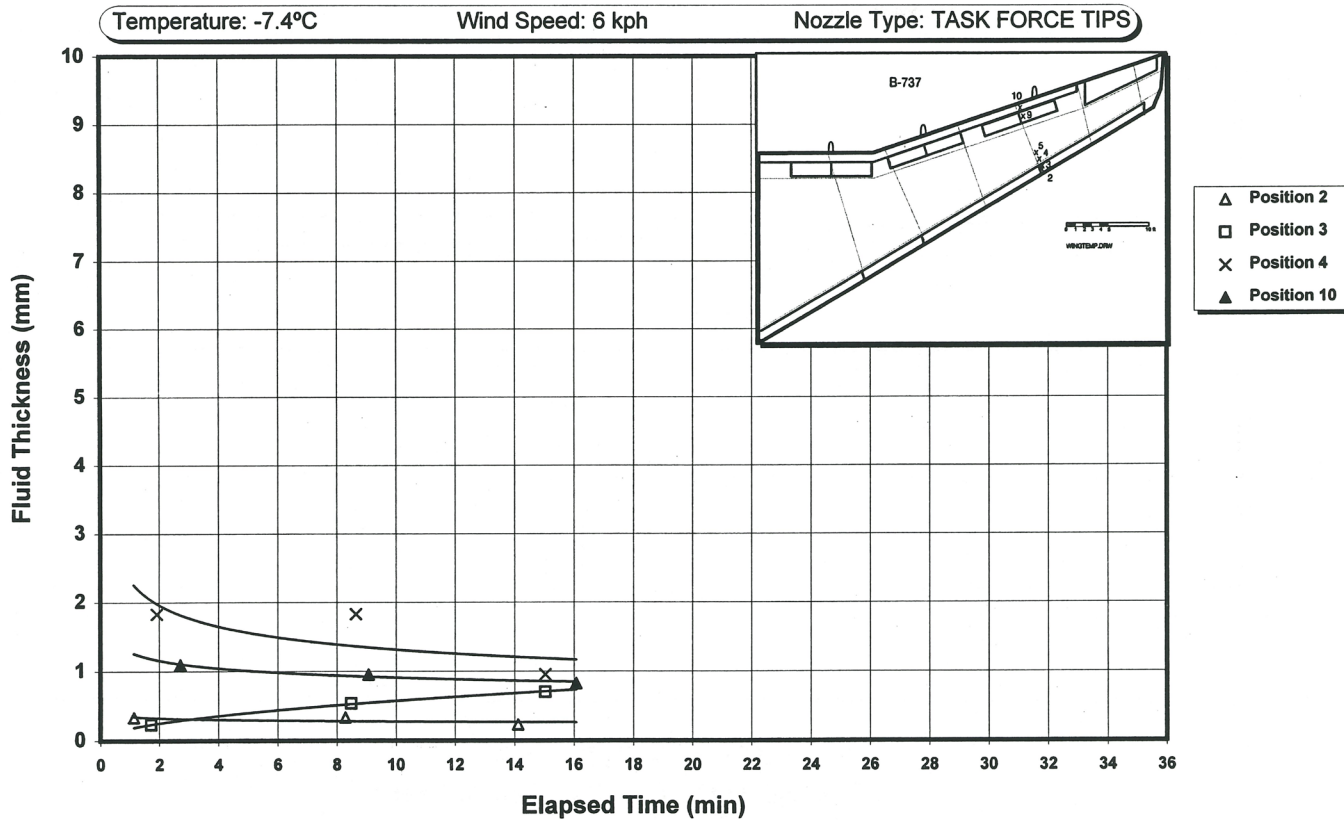


FIGURE D.4
FLUID THICKNESS DECAY OF VARIOUS WING POSITIONS
B-737, ID# T4 - JANUARY 22, 1997
 1st FLUID: ULTRA TYPE IV / 20 LITRES
 2nd FLUID: NIL



D-5

File: g:\cm1338\analysis\thickness\T4_THPRF.XLS
 At: Run 4
 Printed: 04/12/97, 03:17 PM

FIGURE D.5
 TYPE IV FLUID THICKNESS (STABILIZED) PROFILE - NO PRECIPITATION
 ULTRA ON B-737 WING, ULTRA+ ON PLATES
 ID# T4 - January 22, 1997

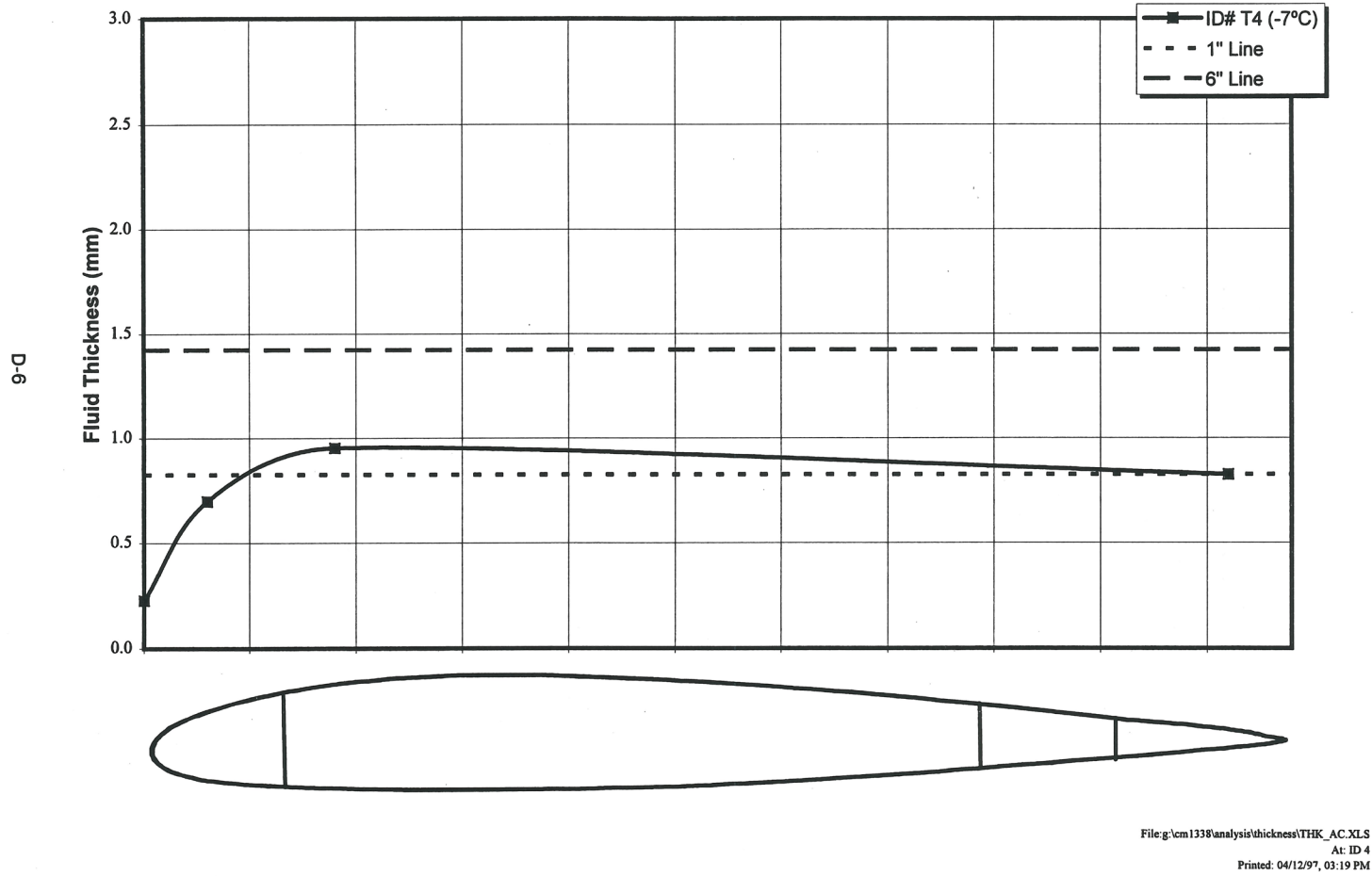


FIGURE D.6
B-737 STABILIZED THICKNESS ON WING PLAN
 ID# T4 - January 22, 1997, Ultra
 (mm)

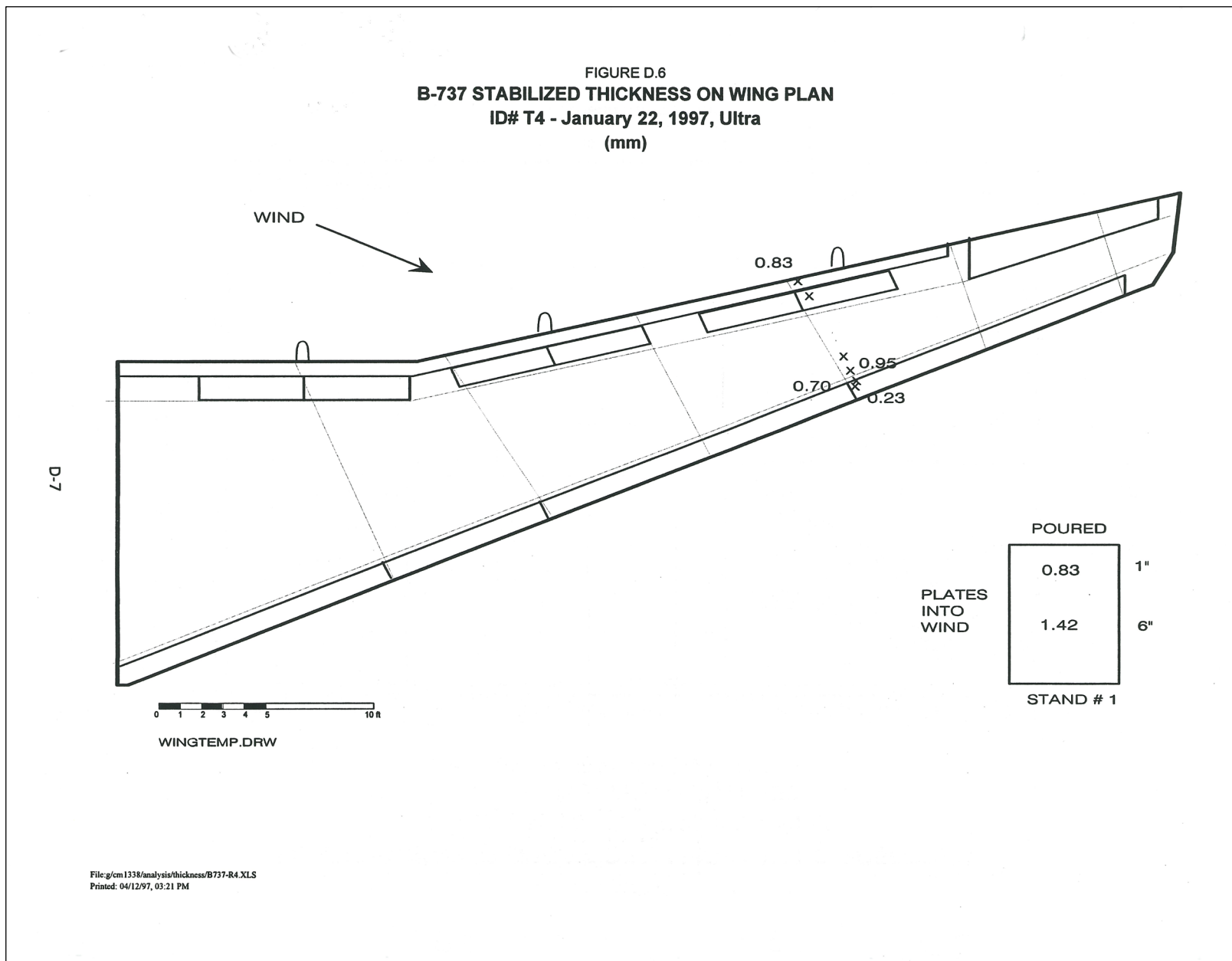
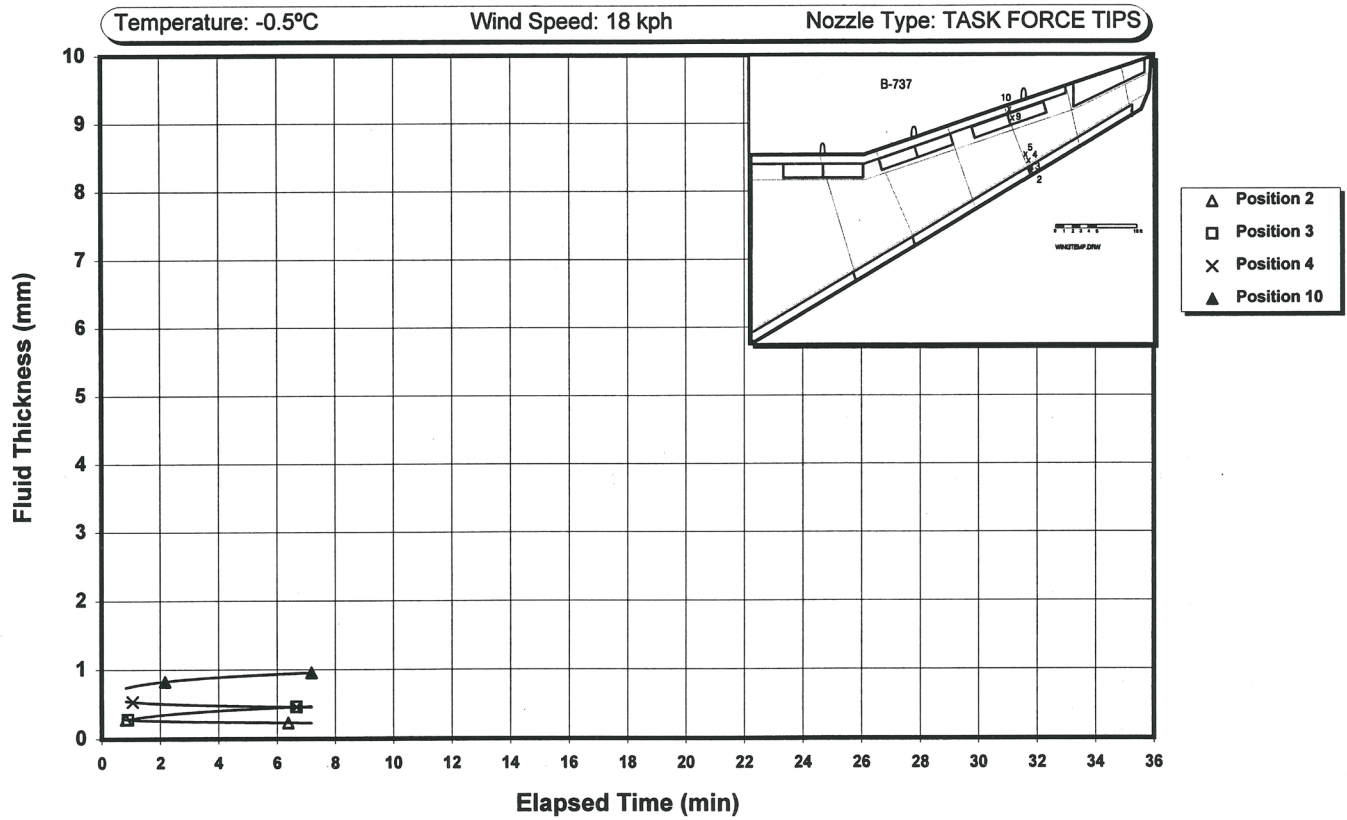


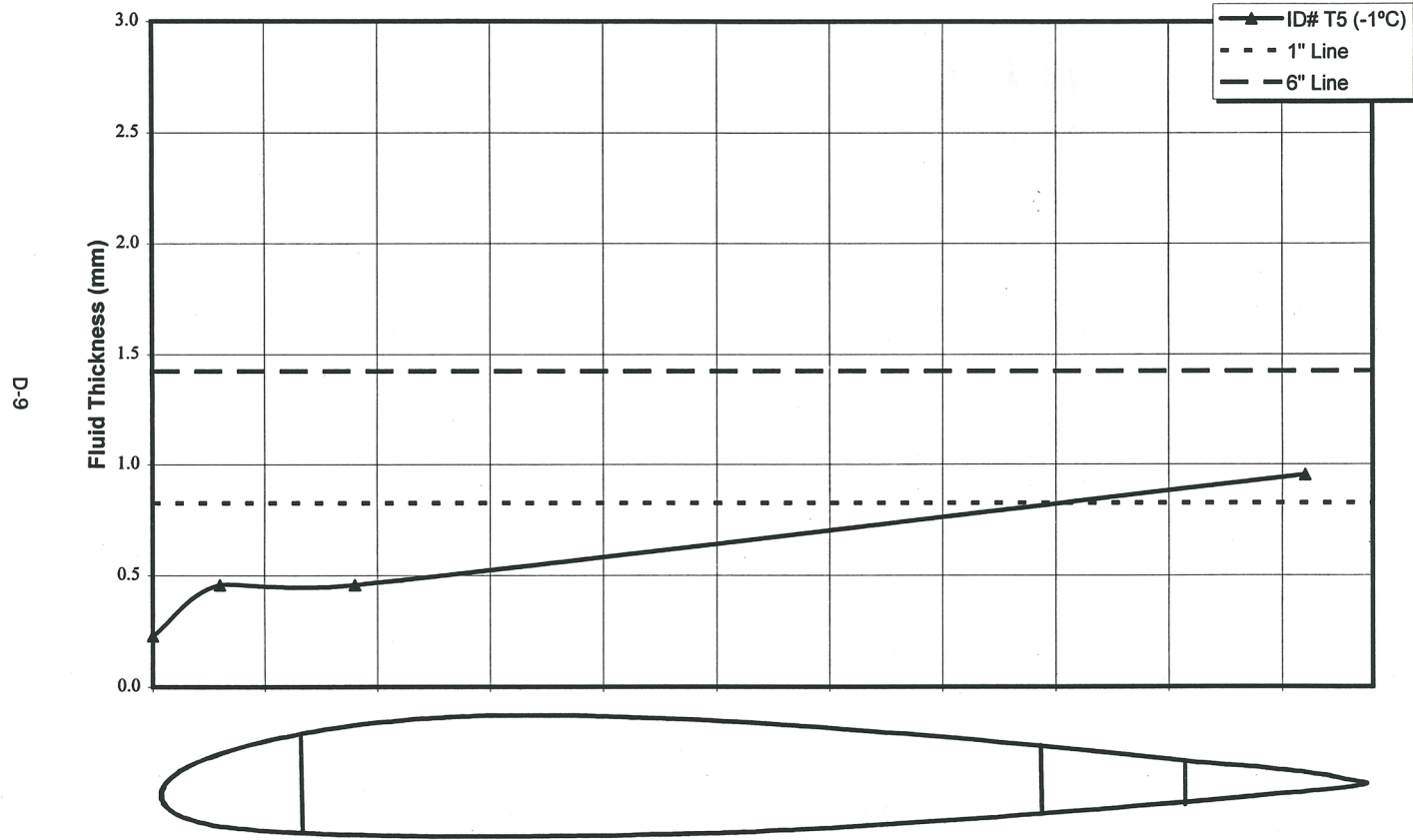
FIGURE D.7
FLUID THICKNESS DECAY OF VARIOUS WING POSITIONS
B-737, ID# T5 - JANUARY 25, 1997
 1st FLUID: XL54 TYPE I / 100 LITRES
 2nd FLUID: ULTRA+ TYPE IV / 75 LITRES



D-8

File:g:\cm1338\analysis\thickness\T5_THPRF.XLS
 At: Run 5
 Print: 04/12/97, 03:22 PM

FIGURE D.8
TYPE IV FLUID THICKNESS (STABILIZED) PROFILE - NO PRECIPITATION
 ULTRA+ OVER XL54 ON B-737 WING, ULTRA+ ON PLATES
 ID# T5 - January 25, 1997



File: g:\cm1338\analysis\thickness\THK_AC.XLS
 At: ID 5
 Printed: 04/12/97, 03:20 PM

FIGURE D.9
B-737 STABILIZED THICKNESS ON WING PLAN
 ID# T5 - January 25, 1997, Ultra+/XL54
 (mm)

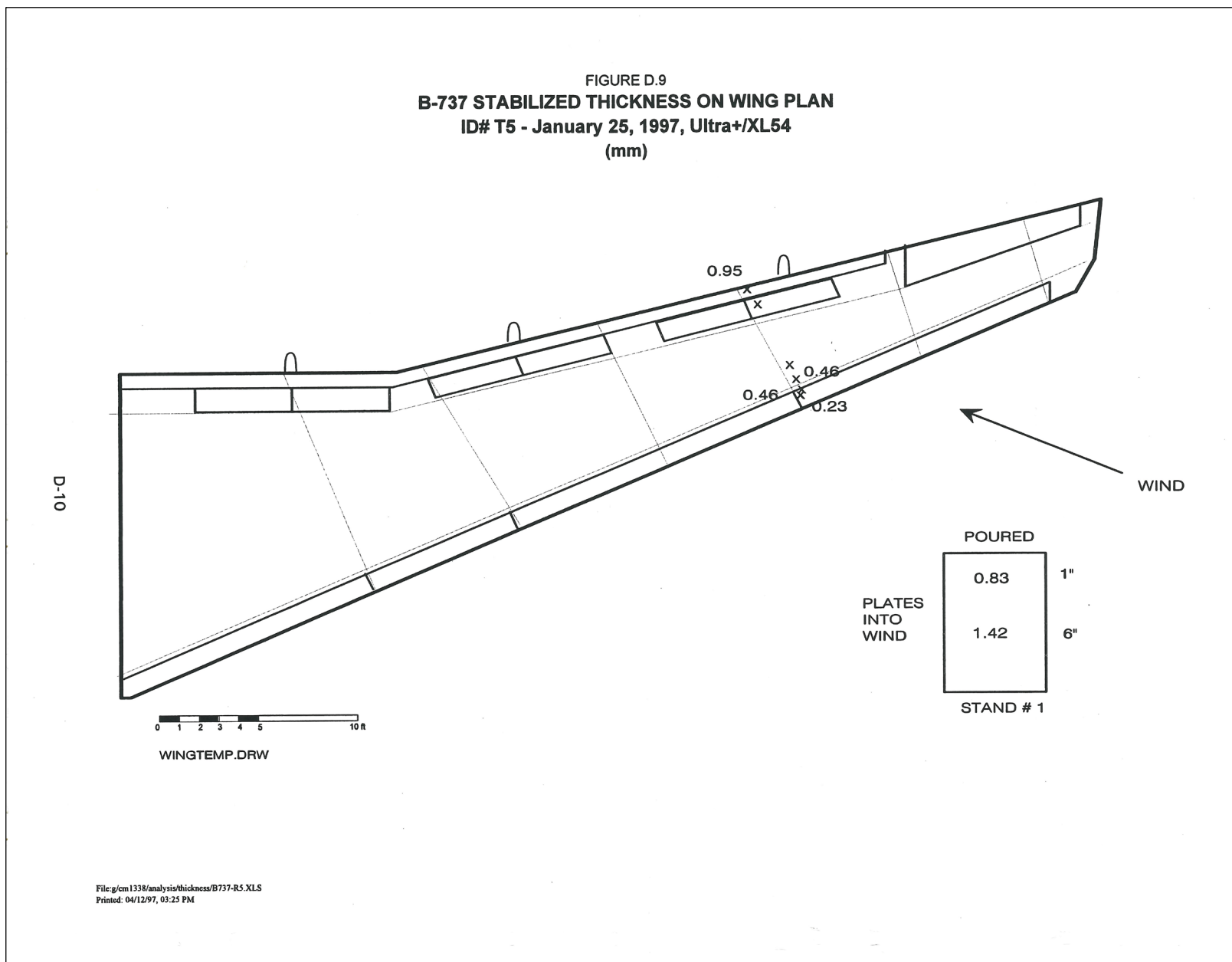
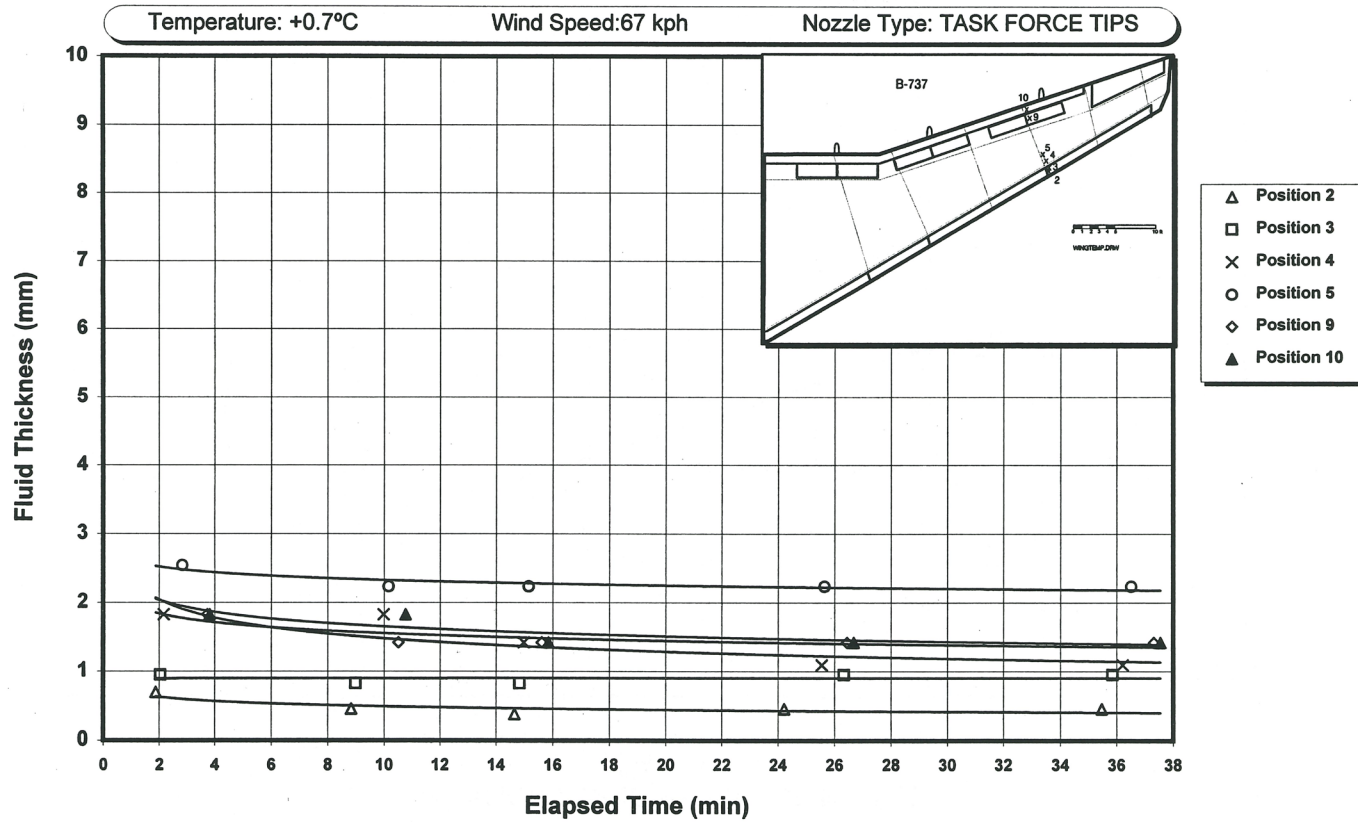


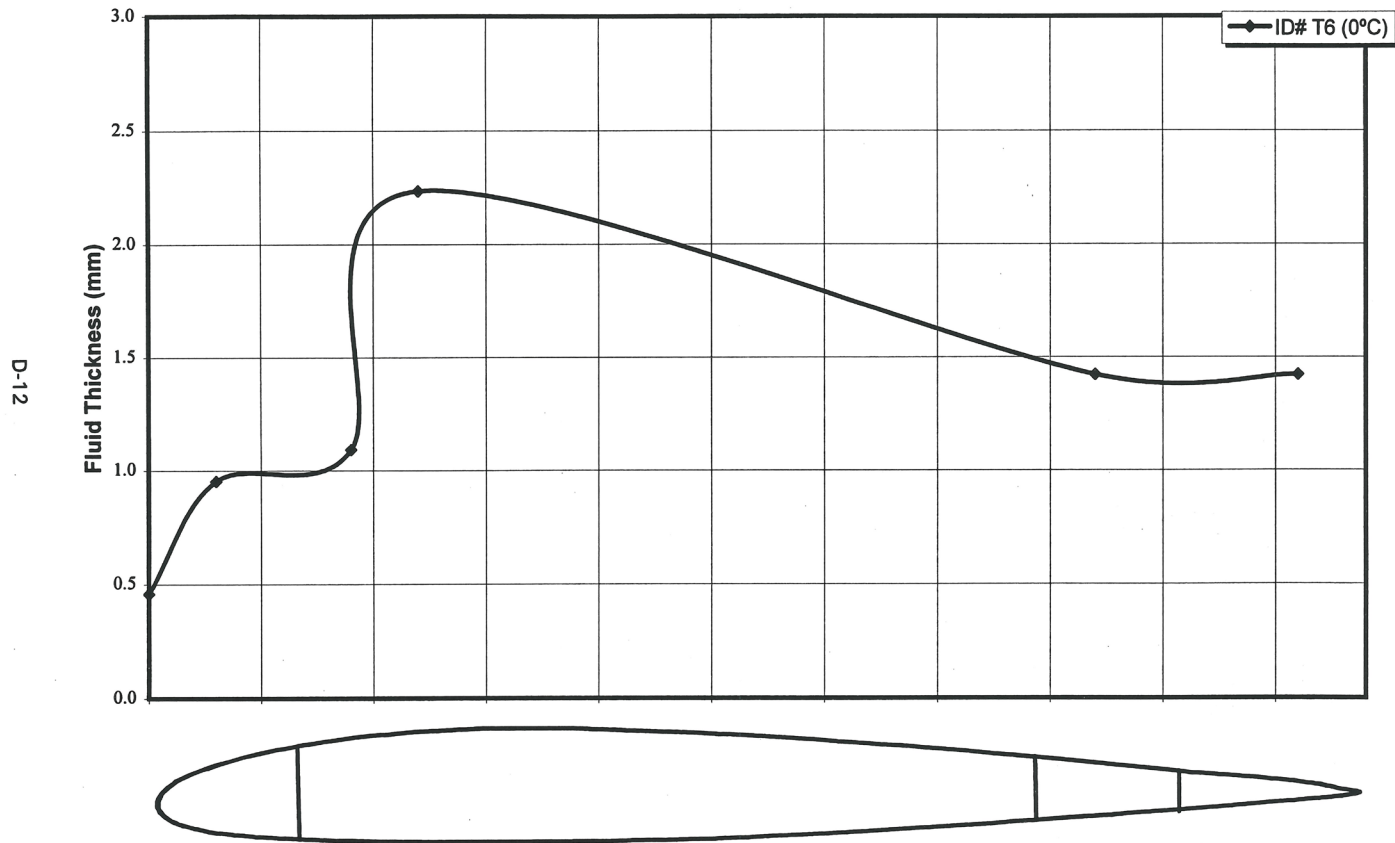
FIGURE D.10
FLUID THICKNESS DECAY OF VARIOUS WING POSITIONS
B-737, ID# T6 - JANUARY 25, 1997
 1st FLUID: ULTRA+ TYPE IV / 175 LITRES
 2nd FLUID: NIL



D-11

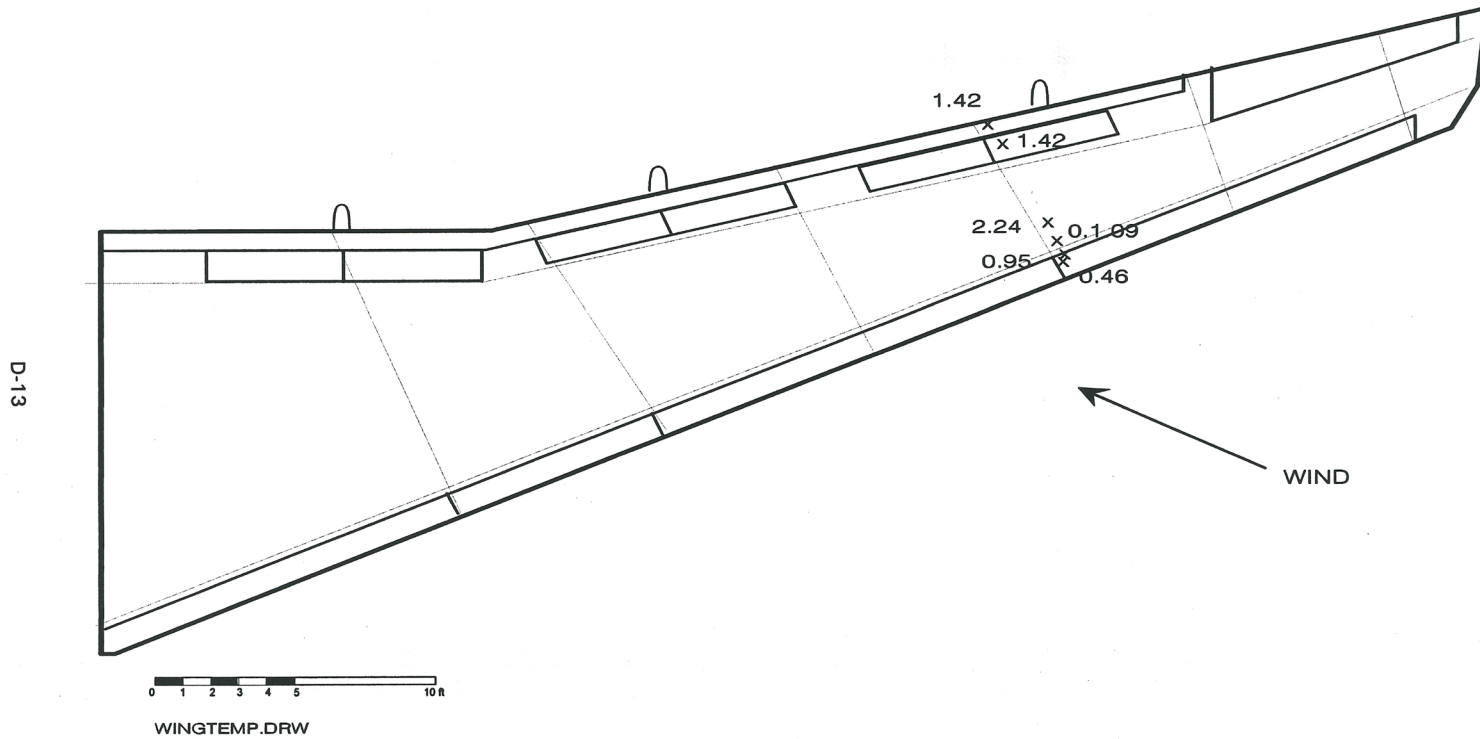
File: g:\cm1338\analysis\thickness\T6_THPRF.XLS
 At: Run 6
 Printed: 04/12/97, 03:22 PM

FIGURE D.11
TYPE IV FLUID THICKNESS (STABILIZED) PROFILE - NO PRECIPITATION
ULTRA+ ON B-737 WING, ULTRA+ ON PLATES
ID# T6 - January 25, 1997



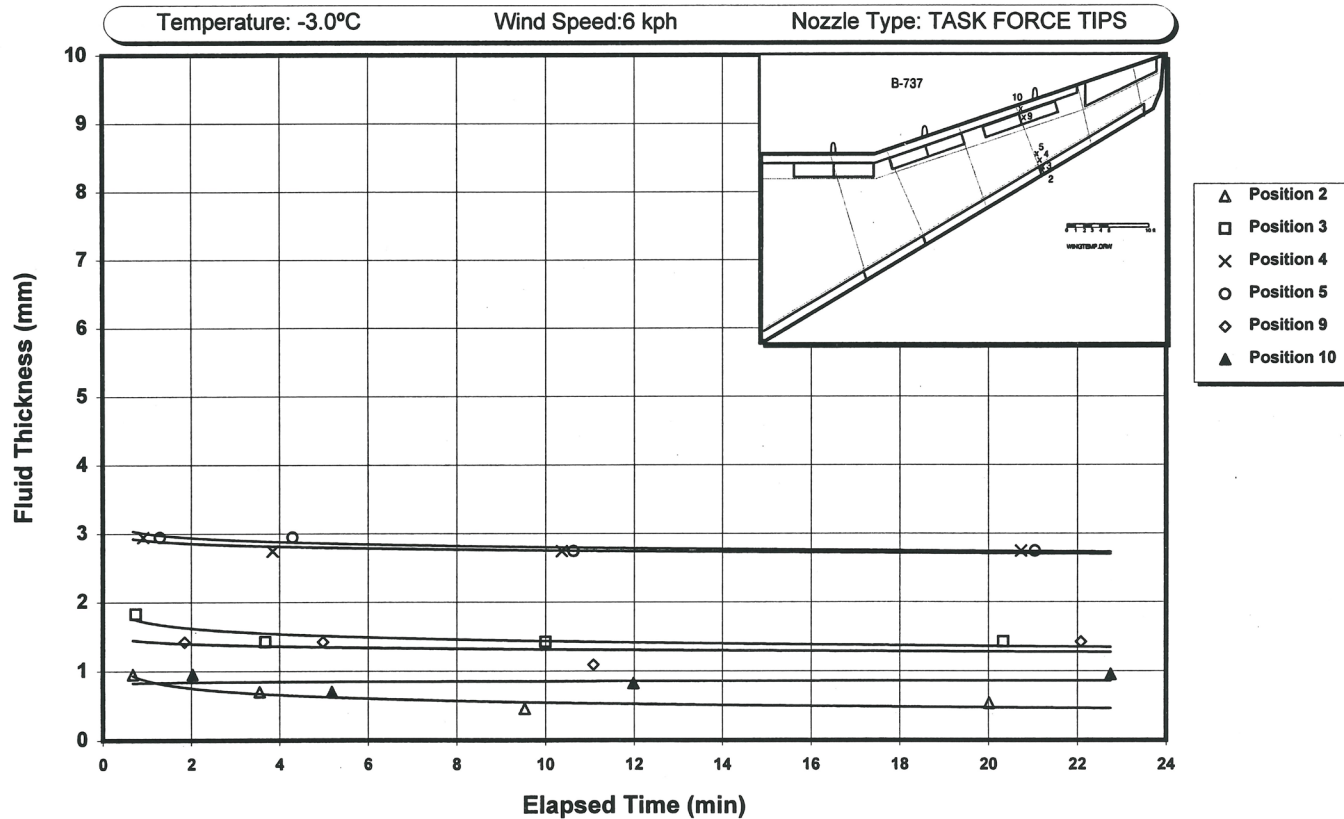
File:g:\cm1338\analysis\thickness\THK_AC.XLS
At: ID 6
Printed: 04/12/97, 03:20 PM

FIGURE D.12
B-737 STABILIZED THICKNESS ON WING PLAN
ID# T6 - January 25, 1997, Ultra+
(mm)



File:g/cm1338/analysis/thickness/B737-R6.XLS
Printed: 04/12/97, 03:24 PM

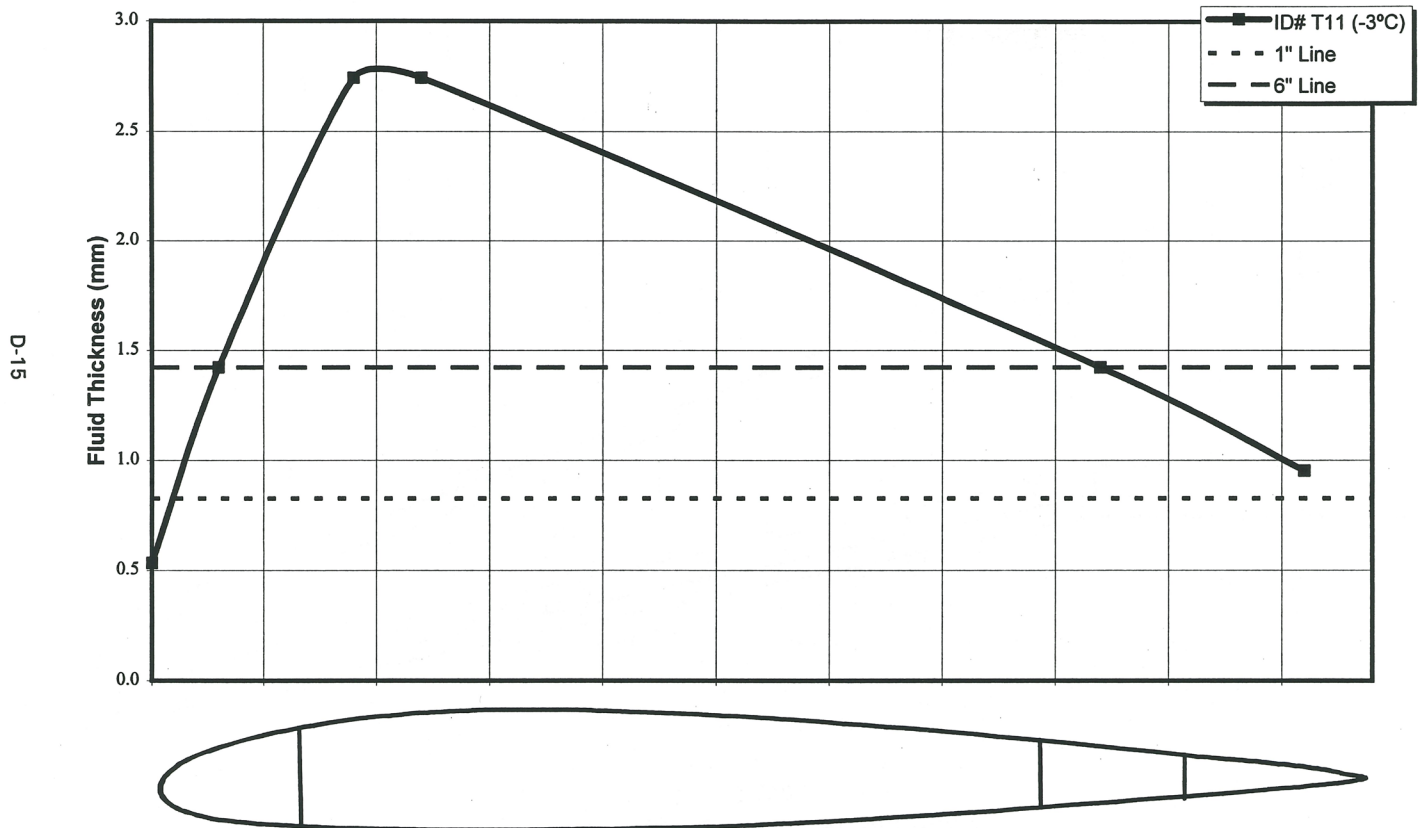
FIGURE D.13
FLUID THICKNESS DECAY OF VARIOUS WING POSITIONS
B-737, ID# T11 - FEBRUARY 21, 1997
 1st FLUID: XL54 TYPE I / 100 LITRES
 2nd FLUID: ULTRA+ TYPE IV / 50 LITRES



D-14

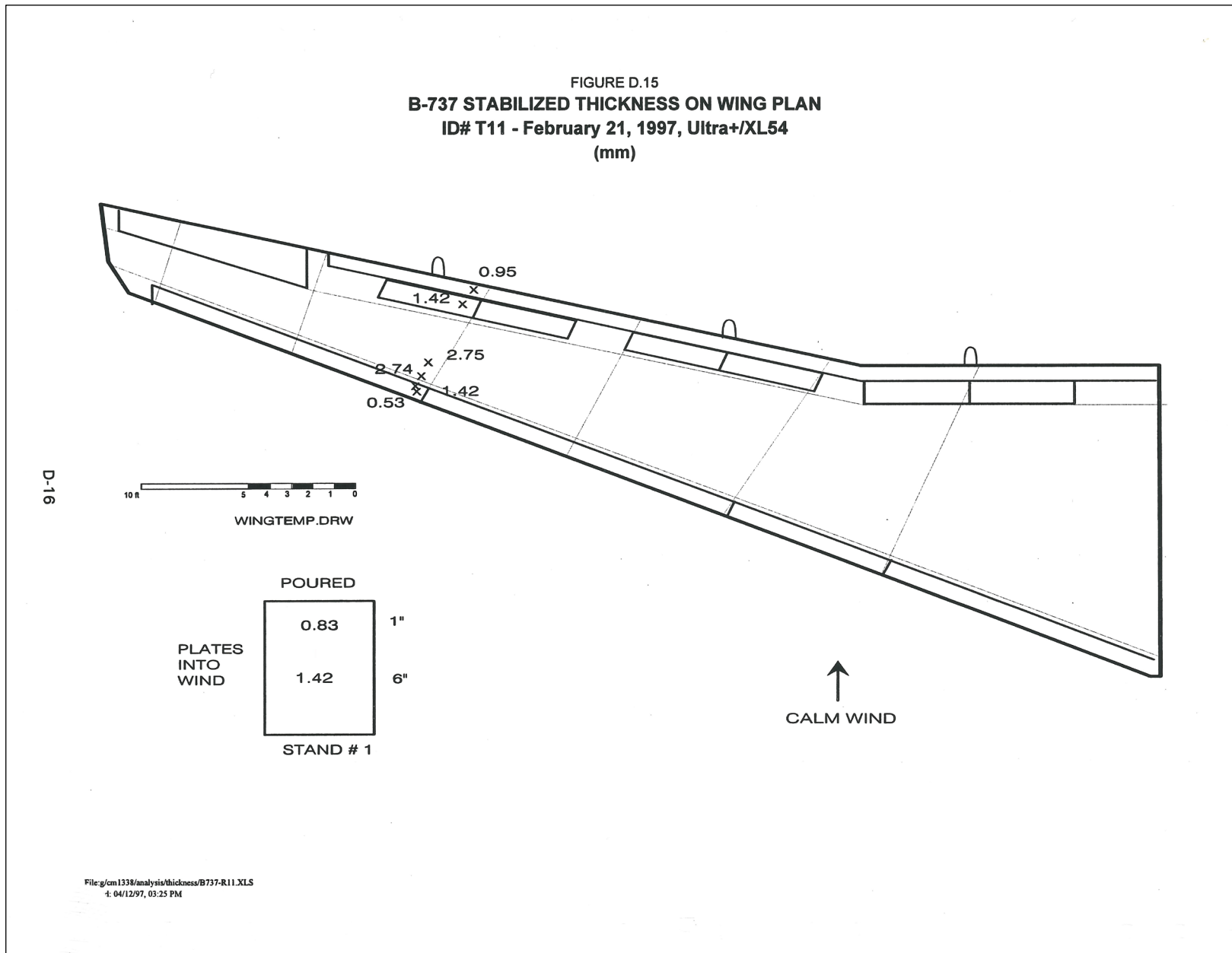
File: g:\cm1338\analysis\thickness\T11_TPRF.XLS
 At: Run 11
 Print: 04/2/97, 03:26:04

FIGURE D.14
TYPE IV FLUID THICKNESS (STABILIZED) PROFILE - NO PRECIPITATION
ULTRA+ OVER XL54 ON B-737 WING, ULTRA+ ON PLATES
ID# T11 - February 21, 1997



File:g:\cm1338\analysis\thickness\THK_AC.XLS
At: ID 11
Printed: 04/12/97, 03:21 PM

FIGURE D.15
B-737 STABILIZED THICKNESS ON WING PLAN
 ID# T11 - February 21, 1997, Ultra+/XL54
 (mm)



APPENDIX E

FLUID THICKNESS TRIALS ON TURBOPROP AIRCRAFT

APPENDIX E - FLUID THICKNESS TRIALS ON TURBOPROP AIRCRAFT

LIST OF FIGURES IN APPENDIX E

- Figure E.1 Location of Fluid Thickness Measuring Points on ATR 42 Wing
- Figure E.2 Type I Fluid Thickness Along Top of Wing; with and without Prop; Run ID # T7 & T8
- Figure E.3 Type IV Fluid Thickness Along Top of Wing; with and without Prop; Run ID # T9
- Figure E.4 Type IV Fluid Thickness Profile on Wing Chord; Run ID # T9
- Figure E.5 Type IV Stabilized Thickness on Wing Plan; Run ID # T9
- Figure E.6 Type IV Fluid Thickness along Top of Wing; with and without Prop; Run ID # T10
- Figure E.7 Type IV Fluid Thickness Profile on Wing Chord; Run ID # T10
- Figure E.8 Type IV Stabilized Thickness on Wing Plan; Run ID # T9

FIGURE E.1
ATR-42 THICKNESS LOCATIONS ON WING PLAN

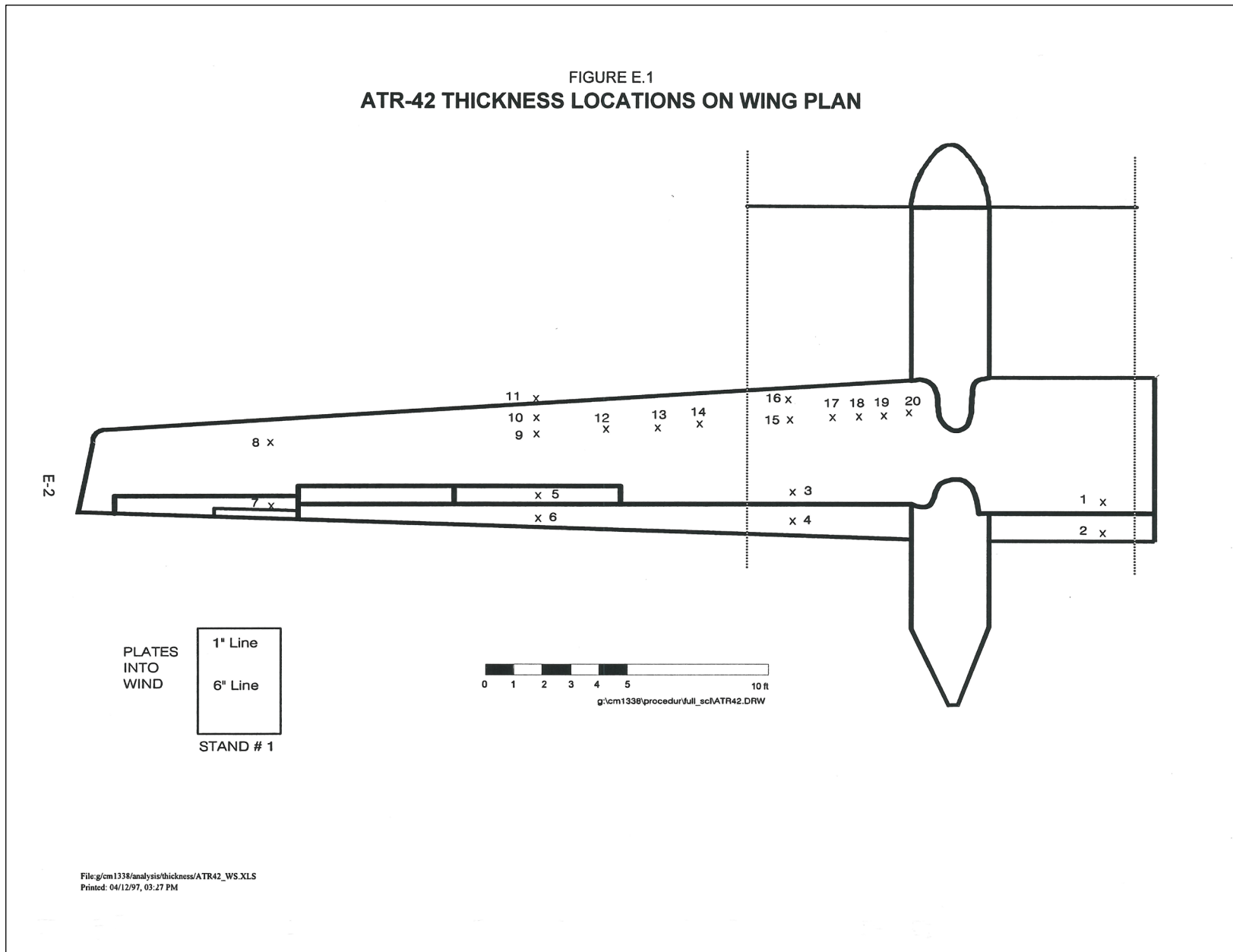
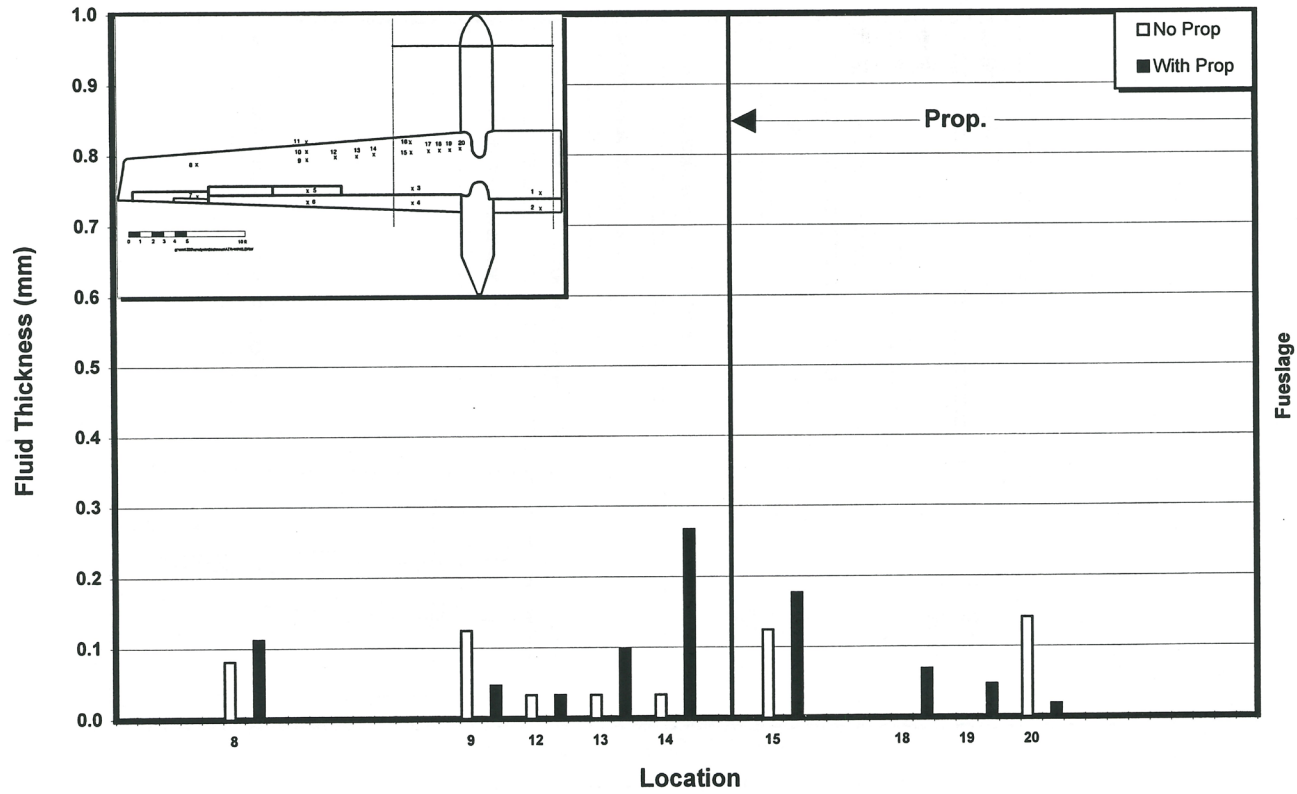
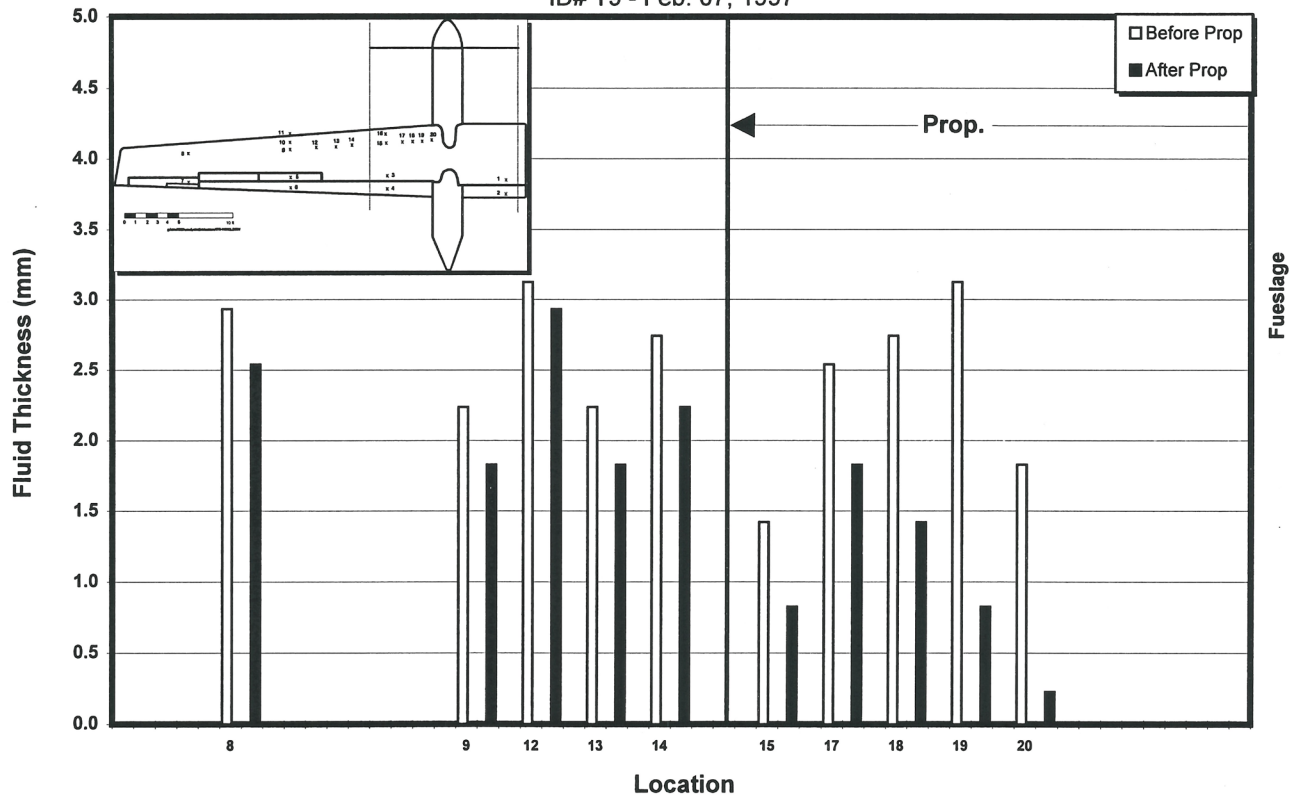


FIGURE E.2
ATR-42 TURBOPROP FLUID STABILIZED THICKNESS
 TYPE I FLUID
 ID# T7 and T8 - Feb. 04, 1997



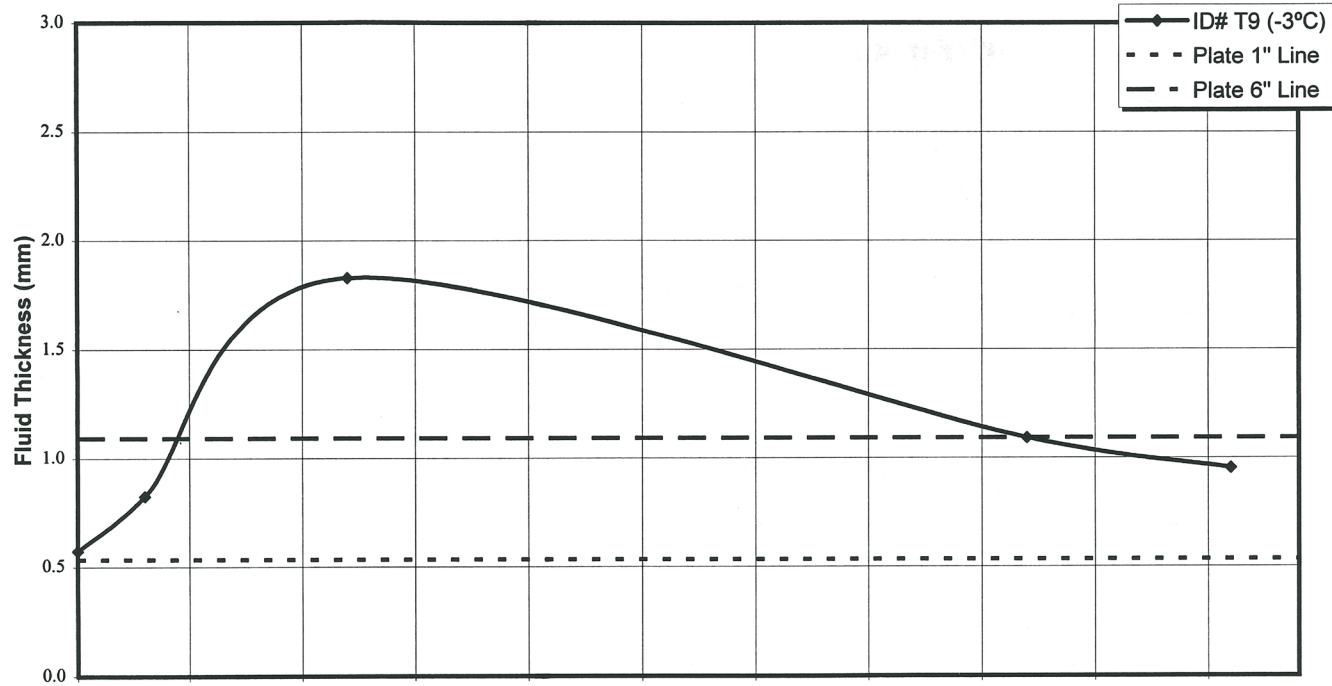
File:g:\cm1338\analysis\thickness\ATR_THK.XLS
 At: 1&2_Feb04
 Printed: 04/12/97 , 03:32 PM

FIGURE E.3
ATR-42 TURBOPROP FLUID STABILIZED THICKNESS
 TYPE IV FLUID
 ID# T9 - Feb. 07, 1997

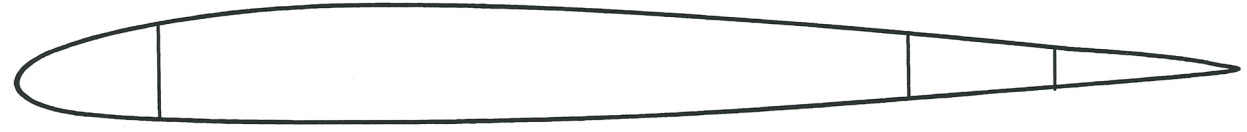


File:g:\cm1338\analysis\thickness\ATR_THK.XLS
 At: 1_Feb07
 Printed: 04/12/97 . 03:30 PM

FIGURE E.4
TYPE IV FLUID THICKNESS (STABILIZED) PROFILE - NO PRECIPITATION
 ULTRA+ OVER XL54 ON ATR-42 WING, ULTRA+ ON PLATES
 ID# T9 - February 07, 1997



E-5



Wing profile is generic as ATR-42 profile was unavailable

File:g:\cm1338\analysis\thickness\THK_FB07.XLS
 At: ID 9
 Printed: 04/12/97, 03:33 PM

FIGURE E.5
ATR-42 STABILIZED THICKNESS ON WING PLAN
 ID# T9 - February 07, 1997, Ultra+
 (mm)

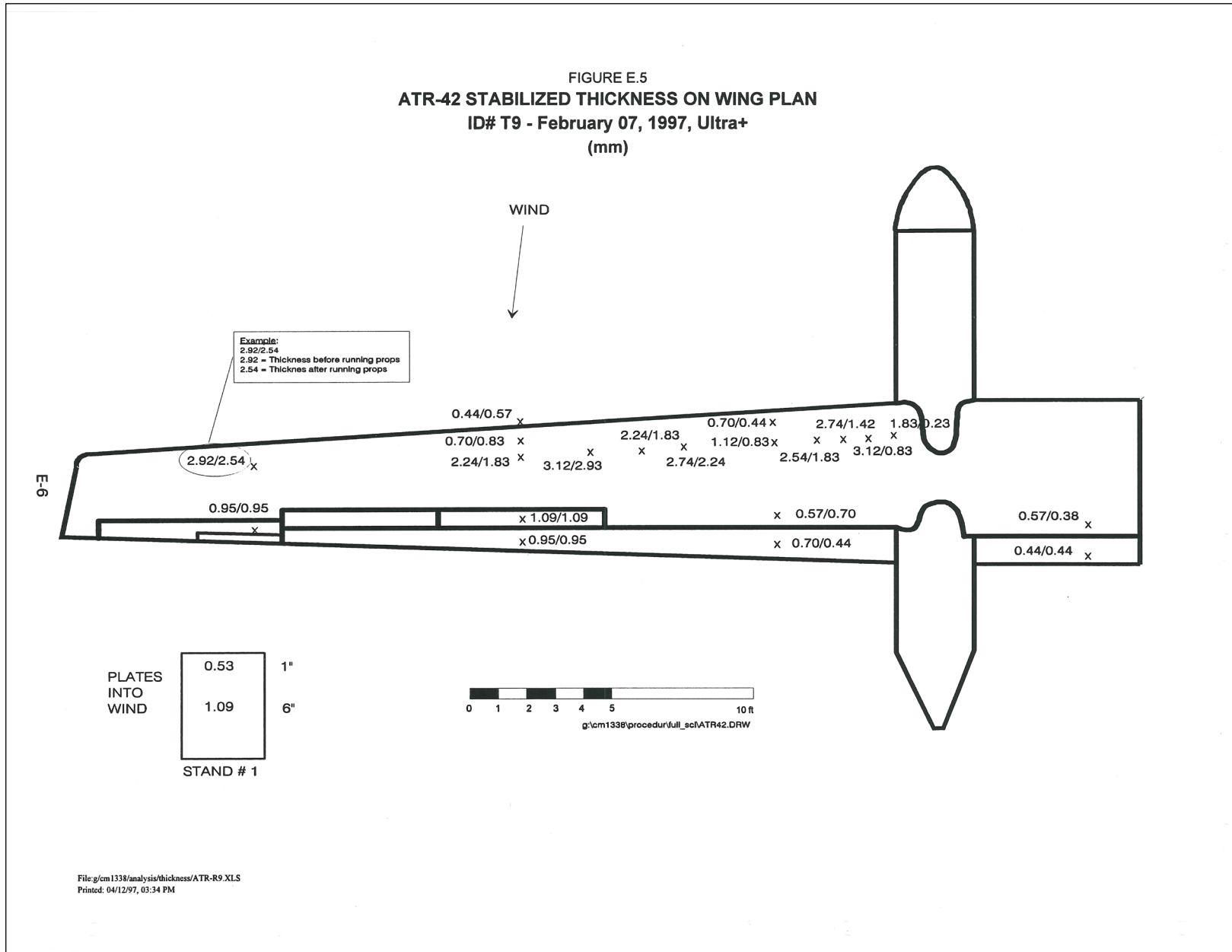
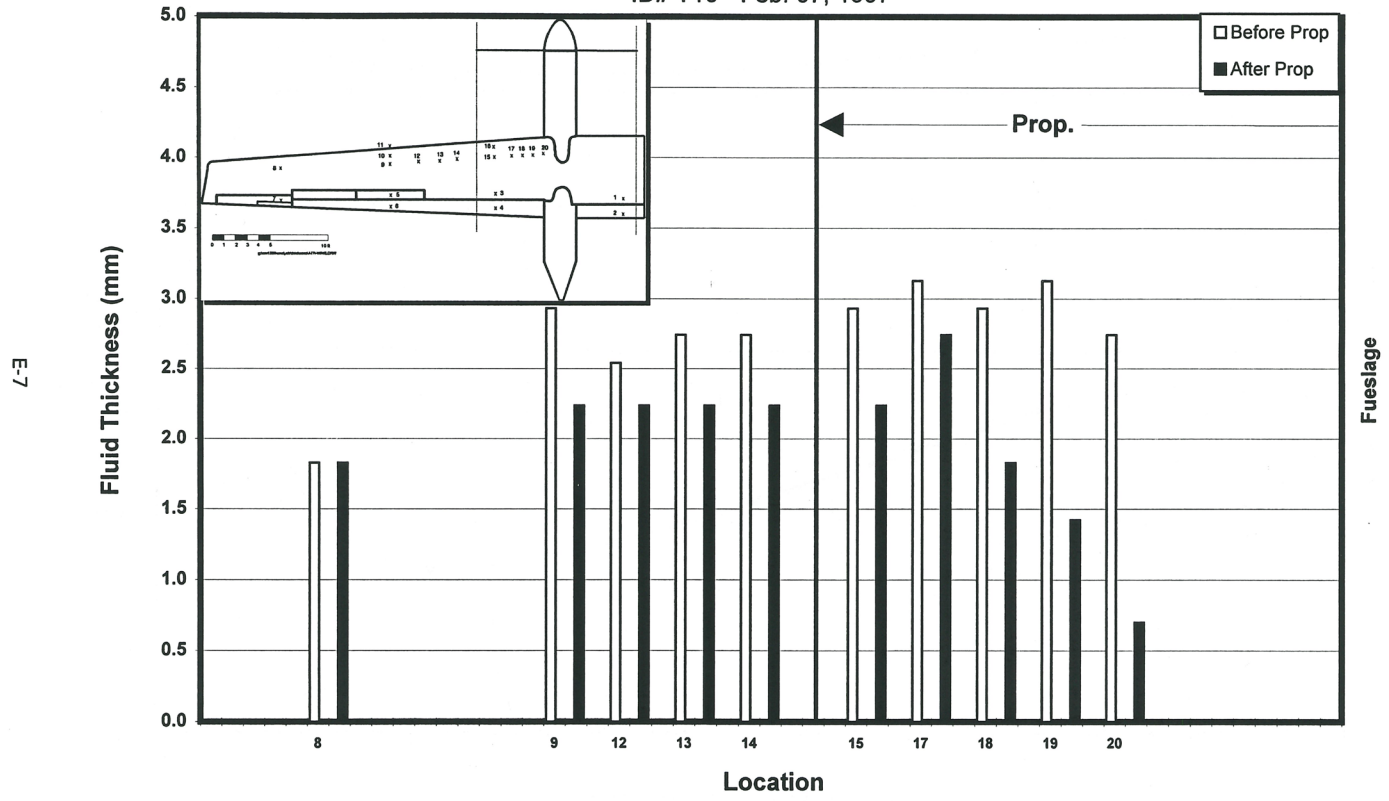
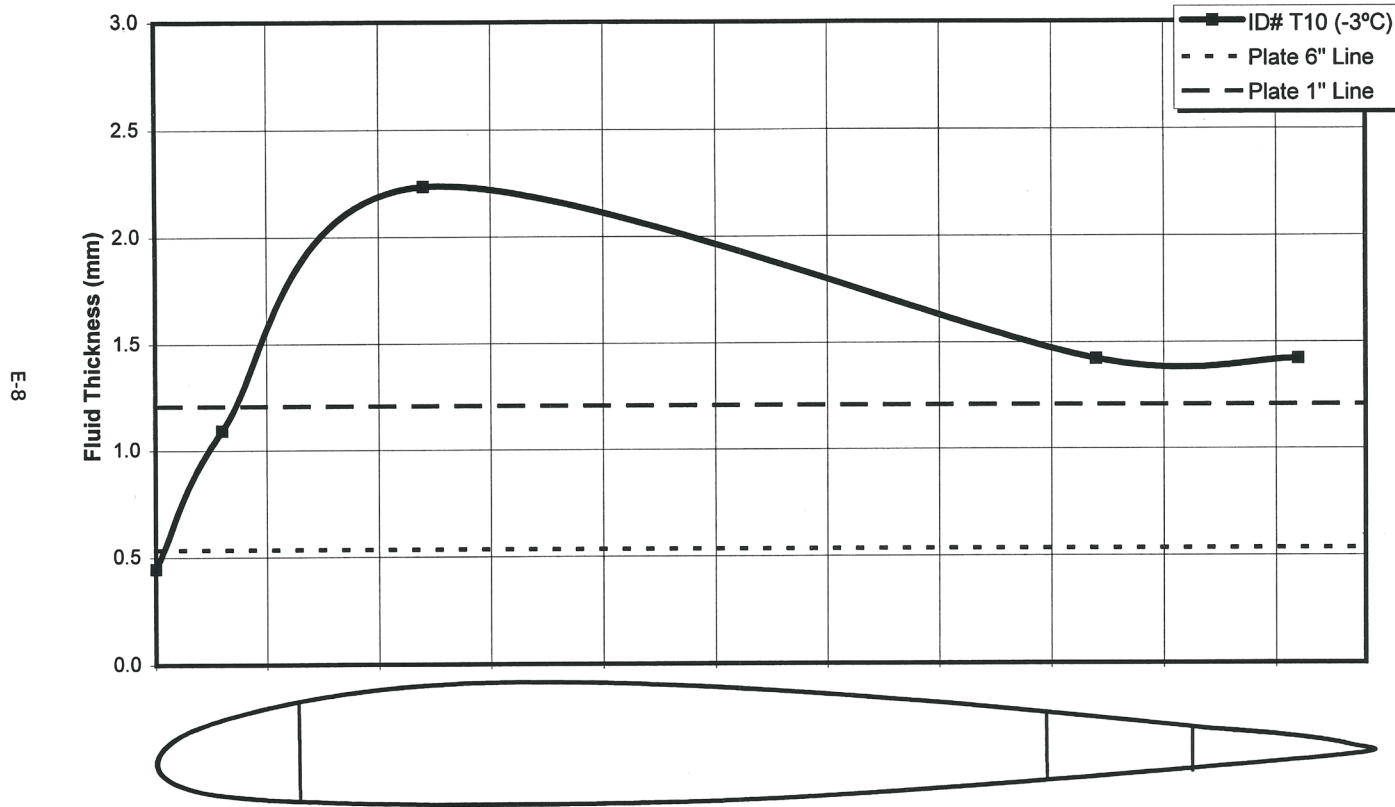


FIGURE E.6
ATR-42 TURBOPROP FLUID STABILIZED THICKNESS
 TYPE IV FLUID
 ID# T10 - Feb. 07, 1997



File:g:\cm1338\analysis\thickness\ATR_THK.XLS
 At: 2_Feb07
 Printed: 04/12/97, 03:31 PM

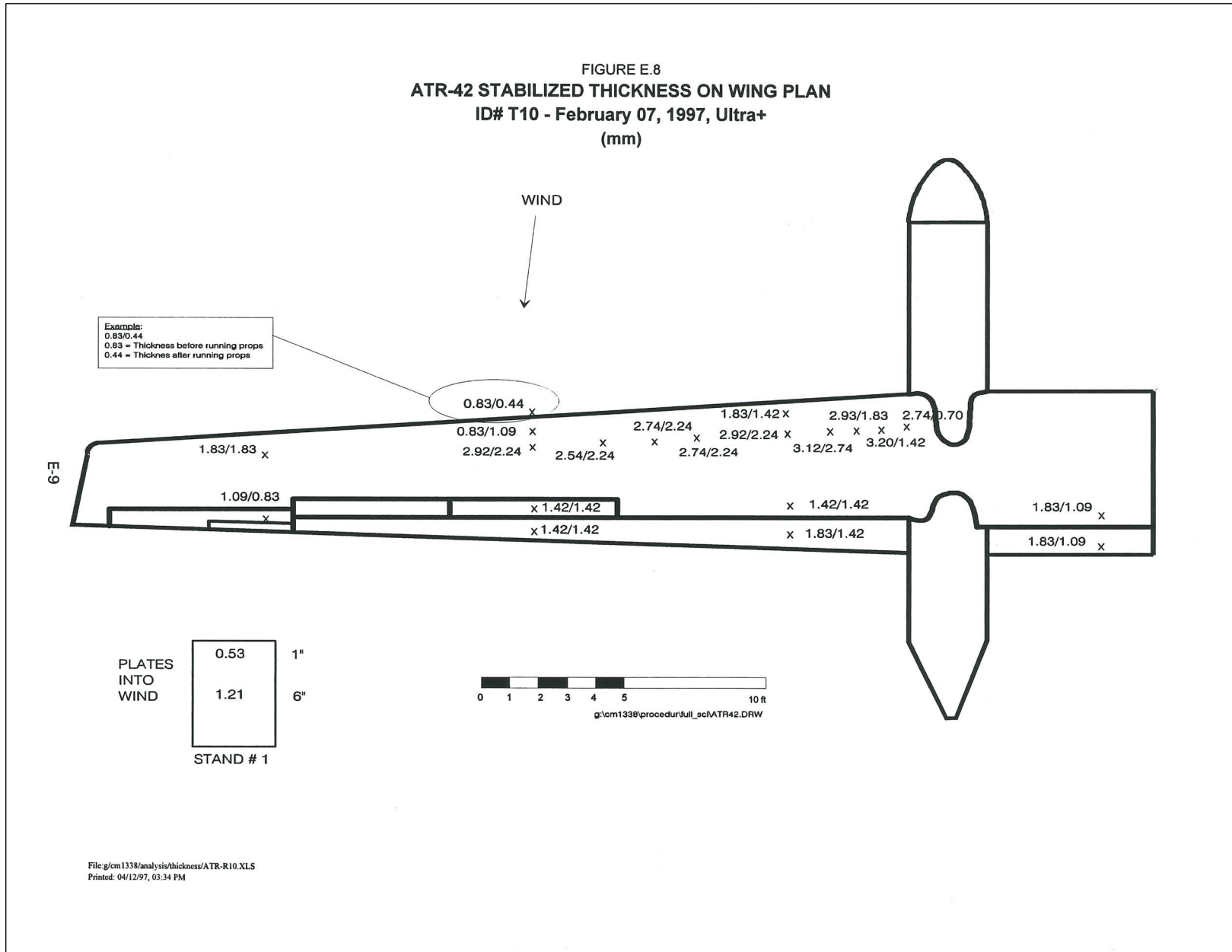
FIGURE E.7
TYPE IV FLUID THICKNESS (STABILIZED) PROFILE - NO PRECIPITATION
 ULTRA+ OVER XL54 ON ATR-42 WING, ULTRA+ ON PLATES
 ID# T10 - February 07, 1997

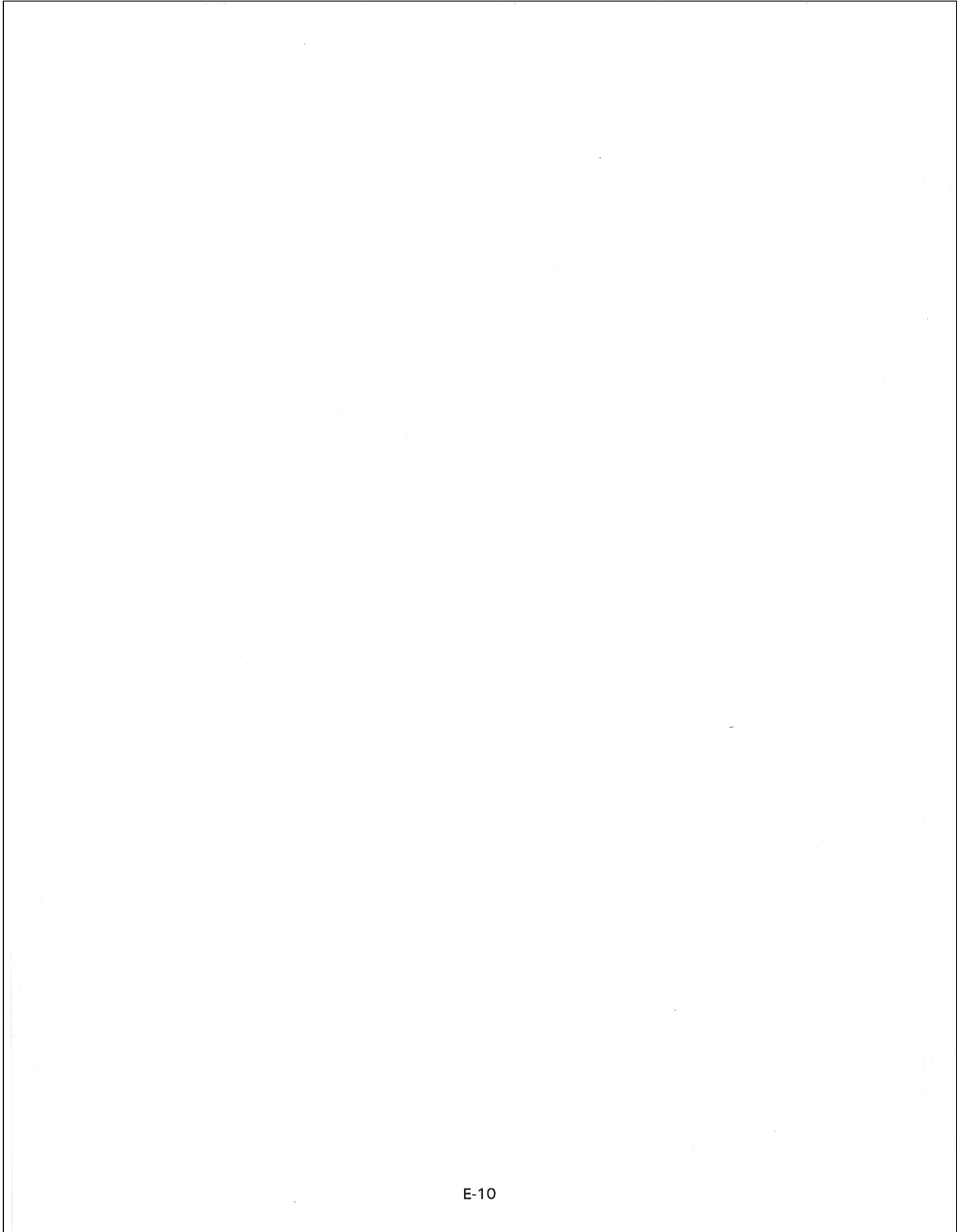


Wing profile is generic as ATR-42 profile was unavailable

File: g:\cm1338\report\full_scl\THK_FB07.XLS
 At: ID 10
 Printed: 04/12/97, 03:32 PM

FIGURE E.8
 ATR-42 STABILIZED THICKNESS ON WING PLAN
 ID# T10 - February 07, 1997, Ultra+
 (mm)





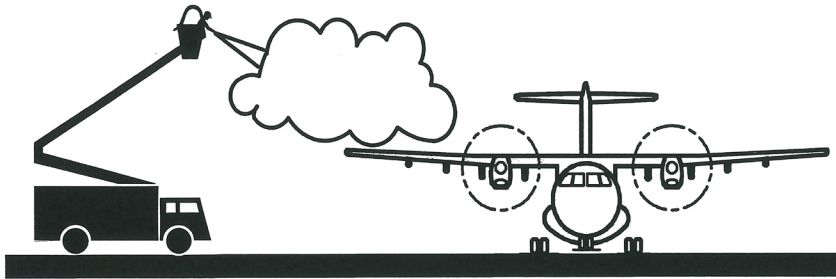
E-10

APPENDIX F

DOCUMENTATION OF WING AREA VISIBLE TO FLIGHT CREW

Appendix F

Documentation of Wing Area Visible to Flight Crew



Prepared for

Transportation Development Centre

on behalf of

Civil Aviation

Safety and Security

Transport Canada

and

The Federal Aviation Administration

William J. Hughes Technical Centre

by

APS AVIATION INC. **APS**

December 1997

g:\cm1338\report\full-scl\appx_f.drw

1. BACKGROUND

At the request of Transportation Development Centre of Transport Canada, APS Aviation Inc. undertook a study to document, through a series of photographs, the area of the aircraft wing that is visible to the flight crew. This activity was intended to include each of the major aircraft types operating in Canada, and was to include a representation of visibility during night-time and precipitation.

To date, photographic documentation has been conducted on four different aircraft types, and results are included in this report.

2. OBJECTIVE

The objective of this activity was to document and demonstrate through a series of photographs, and videotape, the area of the wing that is visible to a viewer from the interior of the aircraft cabin. Viewing positions from the flight deck as well as from various suitable windows in the passenger cabin were to be included, as well as a representation of the ability to view the wing during night-time and during precipitation.

3. PROCEDURE

Arrangements were made with operators at Dorval International Airport to gain access to aircraft between flights. Coordination with carrier operations staff and reference to airport flight schedule displays enabled photo sessions to take place during the short period between flights when the cabin was free of passengers.

A record was maintained of the operator, aircraft type, tail number and date.

From the flight deck side windows, photos were taken of the wing as it appeared to the observer. As many photos as necessary to capture the visible portion of the wing were taken. When possible, photos were taken leaning out the open side window, as well as through the closed window.

From the passenger cabin, photos were taken from several positions, including windows at the wing leading edge, at the trailing edge and at the overwing emergency exit. Windows further back in the cabin were also used in some aircraft types. Seat row numbers were recorded for each position used.

The series of photos was repeated for the opposite side of the cabin if it appeared that visibility was different.

For high wing aircraft, photos were taken from cabin windows that offered a view of the wing leading edge. Additional perspectives, such as from the open rear passenger door on the ATR 42, were photographed, when possible.

During the photographic sessions, the wings were observed with the naked eye, and with the assistance of a pair of field binoculars (7X magnification) to assess the value of an optical aid of this type.

4. RESULTS

Visibility of wing area was documented for four aircraft types; Boeing 737, Airbus A320, ATR 42 and Fokker F28. A series of documentation photographs for each aircraft type is included at the end of this section. Tables 5.1 to 5.5 describe the observers location for each image.

The Boeing 737 aircraft was photographed on two separate sessions, one of which was during a snow storm. On that occasion the aircraft had returned to the gate following deicing due to an unserviceability, and the passengers had been taken off. This unique opportunity presented views of a wing as it appeared when the anti-icing fluid had failed, and snow had begun to accumulate on wing surfaces. As well, cabin windows located in the vicinity of the wing illustrated the reduced visibility caused by snow sticking on the window due to fluid overspray. Windows further back in the cabin remained clear and offered a good view of the wing surface, as did windows located ahead of the wing leading edge.

It was found that the binoculars offered a much enhanced view of the wing surface. Visibility of fine detail such as rivets at the outer end of the wing surface was made possible. Although not discernable with the naked eye, frost was able to be seen on the wing of the Boeing 737 with the use of the binoculars.

5. FURTHER ACTIVITIES

To date, four aircraft types have been documented in this activity, including one aircraft which was photographed during a snow storm.

Documentation of other aircraft types, and during different conditions of precipitation and night-time, is outstanding and requires approval for completion.

Table 5.1: Visibility of A320 Wing

Photo	Number	Title
5.1	A320-1	Aircraft Tail Number
5.2	A320-2	View of Wing from Flight Deck Closed Window
5.3	A320-3	Over Wing Exit Window - Row 10
5.4	A320-4	Inner Wing - Row 10
5.5	A320-5	Wing - Row 10
5.6	A320-6	Rear of Wing - Row 10
5.7	A320-7	Window at Wing Trailing Edge - Row 15
5.8	A320-8	Wing Trailing Edge - Row 15
5.9	A320-9	Inner Wing - Row 15
5.10	A320-10	Outer Wing - Row 15
5.11	A320-11	Window at Wing Leading Edge - Row 6
5.12	A320-12	Wing Leading Edge - Row 6
5.13	A320-13	Wing - Row 6

Table 5.2: Visibility of B737 Wing

Photo	Number	Title
5.14	B737-1	Flight Deck Placard - Tail Number
5.15	B737-2	View of Wing from Flight Deck - Closed Window
5.16	B737-3	Over Wing Exit Window - Row 9
5.17	B737-4	Inner Wing - Row 9
5.18	B737-5	Full Wing - Row 9
5.19	B737-6	Rear of Wing - Row 9
5.20	B737-7	Window at Wing Trailing Edge - Row 15
5.21	B737-8	Inner Wing - Row 15
5.22	B737-9	Full Wing - Row 15
5.23	B737-10	Window at Wing Leading Edge - Row 5
5.24	B737-11	Inner Wing Leading Edge - Row 5
5.25	B737-12	Full Wing - Row 5

Table 5.3: Visibility of B737 Wing During Snowstorm

Photo	Number	Title
5.26	B737-1A	View of Wing from Flight Deck - Window Open
5.27	B737-2A	View of Wing from Flight Deck - Window Closed
5.28	B737-3A	Wing from Over Wing Exit - Fluid and Snow on Window
5.29	B737-4A	Wing from Behind Trailing Edge - Dirty Window
5.30	B737-5A	Inner Wing from Over Wing Exit - Dirty Window
5.31	B737-6A	Wing from Window Forward of Leading Edge

Table 5.4: Visibility of ATR-42 Wing

Photo	Number	Title
5.32	ATR-42-1	Aircraft Tail Number
5.33	ATR-42-2	Forward Window in Passenger Cabin - Row 1
5.34	ATR-42-3	View of Inner Wing - Row 1
5.35	ATR-42-4	View of Outer Wing - Row 1
5.36	ATR-42-5	Port Wing From Open Passenger Door
5.37	ATR-42-6	Inner Port Wing from Open Door

Table 5.5: Visibility of F28 Wing

Photo	Number	Title
5.38	F28-1	Aircraft Tail Number
5.39	F28-2	Over Wing Exit Window - Row 8
5.40	F28-3	Wing Leading Edge - Row 8
5.41	F28-4	Full Wing - Row 8
5.42	F28-5	Window at Wing Trailing Edge - Row 12
5.43	F28-6	Inner Wing - Row 12
5.44	F28-7	Full Wing - Row 12
5.45	F28-8	Full Wing - Row 12
5.46	F28-9	Window at Wing Leading Edge - Row 5
5.47	F28-10	Wing Leading Edge - Row 5
5.48	F28-11	Flight Deck Placard - Tail Number
5.49	F28-12	View of Wing from Flight Deck - Closed Window
5.50	F28-13	Wing from Flight Deck - Open Window

Photo 5.1: Aircraft Tail Number (A320-1)



Photo 5.2: View of Wing from Flight Deck Closed Window (A320-2)



Photo 5.3: Over Wing Exit Window - Row 10 (A320-3)



Photo 5.4: Inner Wing - Row 10 (A320-4)



Photo 5.5: Wing - Row 10 (A320-5)



Photo 5.6: Rear of Wing - Row 10 (A320-6)



Photo 5.7: Window at Wing Trailing Edge - Row 15 (A320-7)



Photo 5.8: Wing Trailing Edge - Row 15 (A320-8)



Photo 5.9: Inner Wing - Row 15 (A320-9)



Photo 5.10: Outer Wing - Row 15 (A320-10)



Photo 5.11: Window at Wing Leading Edge - Row 6 (A320-11)



Photo 5.12: Wing Leading Edge - Row 6 (A320-12)



Photo 5.13: Wing - Row 6 (A320-13)



Photo 5.14: Flight Deck Placard - Tail Number (B737-1)



Photo 5.15: View of Wing from Flight Deck - Closed Window (B737-2)



Photo 5.16: Over Wing Exit Window - Row 9 (B737-3)



Photo 5.17: Inner Wing - Row 9 (B737-4)



Photo 5.18: Full Wing - Row 9 (B737-5)



Photo 5.19: Rear of Wing - Row 9 (B737-6)



Photo 5.20: Window at Wing Trailing Edge - Row 15 (B737-7)



Photo 5.21: Inner Wing - Row 15 (B737-8)



Photo 5.22: Full Wing - Row 15 (B737-9)



Photo 5.23: Window at Wing Leading Edge - Row 5 (B737-10)



Photo 5.24: Inner Wing Leading Edge - Row 5 (B737-11)



Photo 5.25: Full Wing - Row 5 (B737-12)



Photo 5.26: View of Wing from Flight Deck - Window Open (B737-1A)



Photo 5.27: View of Wing from Flight Deck - Window Closed (B737-2A)

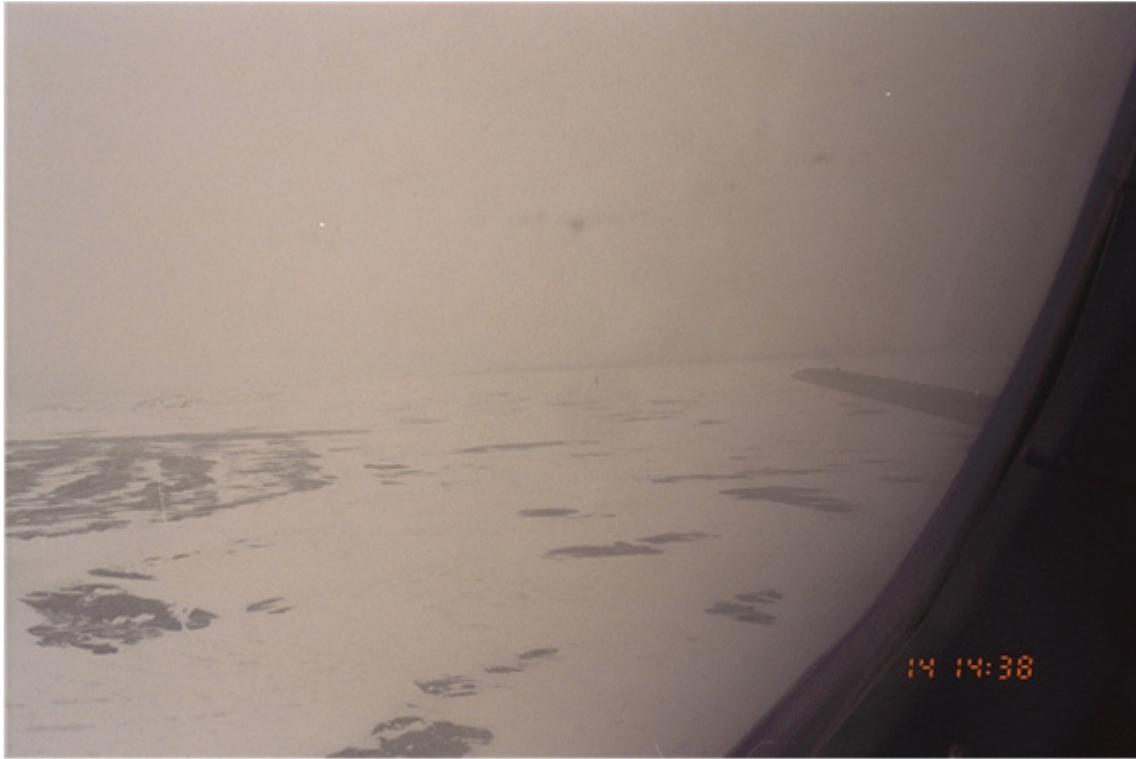


Photo 5.28: Wing from Over Wing Exit - Fluid and Snow on Window (B737-3A)



Photo 5.29: Wing from Behind Trailing Edge - Dirty Window (B737-4A)



Photo 5.30: Inner Wing from Over Wing Exit - Dirty Window (B737-5A)



Photo 5.31: Wing from Window Forward of Leading Edge (B737-6A)



Photo 5.32: Aircraft Tail Number (ATR-42-1)



Photo 5.33: Forward Window in Passenger Cabin - Row 1 (ATR-42-2)



Photo 5.34: View of Inner Wing - Row 1 (ATR-42-3)



Photo 5.35: View of Outer Wing - Row 1 (ATR-42-4)



Photo 5.36: Port Wing from Open Passenger Door (ATR-42-5)



Photo 5.37: Inner Port Wing from Open Door (ATR-42-6)



Photo 5.38: Aircraft Tail Number (F28-1)



Photo 5.39: Over Wing Exit Window - Row 8 (F28-2)



Photo 5.40: Wing Leading Edge - Row 8 (F28-3)



Photo 5.41: Full Wing - Row 8 (F28-4)



Photo 5.42: Window at Wing Trailing Edge - Row 12 (F28-5)



Photo 5.43: Inner Wing - Row 12 (F28-6)



Photo 5.44: Full Wing - Row 12 (F28-7)



Photo 5.45: Full Wing - Row 12 (F28-8)



Photo 5.46: Window at Wing Leading Edge - Row 5 (F28-9)



Photo 5.47: Wing Leading Edge - Row 5 (F28-10)



Photo 5.48: Flight Deck Placard - Tail Number (F28-11)



Photo 5.49: View of Wing from Flight Deck - Closed Window (F28-12)



Photo 5.50: Wing from Flight Deck - Open Window (F28-13)



APPENDIX G

**NARRATIVE REPORTS ON AIRCRAFT TESTS
1996/97 WINTER**

Narrative Reports on Aircraft Tests - 1996/97 Winter

Dry Run - December 12/13, 1996

A training session for the APS team was held at the APS test site from 19:00 to 21:30.

A test run was planned with American Airlines using a Fokker 100 aircraft at the west pad.

The set up at the pad was satisfactory, with four truck trips required to transport all equipment. Four portable generators were used.

The aircraft was sprayed in its initial position (nose into wind) and then turned tail into wind and equipment relocated.

Rain started late during the test.

The test was terminated at 4:30.

Overnight Test - January 9/10, 1997

Tests were planned with American Airlines Fokker 100 using the west pad. The test crew assembled at 22:00, joined by two representatives from AlliedSignal Aerospace Canada, Toronto.

Snowfall was heavier than forecast, and significant amounts of snow had accumulated on the ramp.

The ramp between the American Airlines gate and the west deicing pad was not cleared of snow and American Airlines was unable to tow the aircraft due to heavy drifts. After repeated calls to arrange clearing of snow failed to produce results, the test was cancelled at 2:30, January 10, 1997. Note that the RVSI unit was initially working, then stopped functioning part way through the evening (faulty power supply). The unit was sent out for repairs and returned in time for testing on February 25, 1997.

APPENDIX G - NARRATIVE REPORTS ON AIRCRAFT TESTS - 1996/97 WINTER

Overnight Test, January 15/16, 1997

Tests were planned with a Canadian Airlines International Boeing 737 aircraft at the Air Canada deicing centre.

Snow only started after about 4:00 and less than 2 cm was measured. The forecast had called for 5 to 10 cm between midnight and 5:00. One thickness test was conducted prior to 4:00 (Type IV over Type I).

The aircraft was placed in a crosswind position. Type I fluid was sprayed on both wings prior to the start of the snowfall. Soon thereafter, snow started and intensified and failures were observed. Type I fluid was again sprayed on both wings. Time constraints did not permit the completion of these tests, however first failures were observed on both wings.

The Type IV fluid used in the thickness test was unusually pale and thin. Samples were collected from the truck and sent to Union Carbide for analysis.

Overnight Test, January 21/22, 1997

Tests were planned with a Canadian Airlines International Boeing 737 aircraft at the Air Canada deicing centre.

Poor weather in Toronto resulted in disruptions to the Canadian Airlines International operation and the aircraft arrived at the centre at 00:50, January 22.

The aircraft was initially placed in a tailwind position, but with a wind shift ended in a crosswind position. The weather forecast indicated snow until 2:00, then freezing rain until 7:00. The freezing rain never occurred and only light ice pellets and light snow were seen.

The Type IV fluid in the truck was the same as seen in the January 16 test.

New high intensity flood lights were tried. Two 2,500w mast lights, each driven by a generator, were positioned to light one wing. The other wing was illuminated as in the past with lights mounted on mobile stairs. The new lighting was an improvement.

APPENDIX G - NARRATIVE REPORTS ON AIRCRAFT TESTS - 1996/97 WINTER

Overnight Test, January 24/25, 1997

Tests were planned with a Canadian Airlines International Boeing 737 aircraft at the Air Canada deicing centre.

During the day of January 24, Union Carbide advised APS that the Type IV fluid in the Canadian Airlines International trucks was Ultra, and that the fluid viscosity was severely compromised due to numerous heating/cooling cycles. Union Carbide arranged for new fluid to be delivered (Ultra +) in time for testing. The late delivery of the fluid resulted in truck readiness and aircraft delivery at 1:00.

The aircraft was situated in a crosswind orientation, parallel to the building, and much closer to the building than previous tests. This interfered with normal truck movement (parallel to the leading edge) and the truck approached the wing head on. Application of Type IV fluid was improved after several trials.

Each wing was illuminated with its own mast light and generator, located outboard from the wing tip.

Overnight Test, January 27/28, 1997

Tests were planned with a Canadian Airlines International Boeing 737 aircraft at the Air Canada deicing centre.

The weather forecast called for snow starting in the evening and continuing until noon the following day. By 22:00 a considerable amount of snow had fallen. The rented van was late arriving with lighting equipment as it slid off the road.

Although the aircraft was promised for 23:30, it arrived late at the centre at 1:15.

The aircraft was initially placed with its tail into the wind. During this test the wind shifted resulting in some crosswind from the port side.

Two flood lights were used (one per wing). Testing continued until 5:00; two tests were performed on the port wing with Ultra + (one was incomplete). Three tests were done with Type I on the starboard wing. Snow continued all night.

APPENDIX G - NARRATIVE REPORTS ON AIRCRAFT TESTS - 1996/97 WINTER

Test - February 4, 1997

Inter-Canadian ATR 42

Weather - wind about 30 kph; temperature -6°C; clear skies

Inter-Canadian was prepared for test, with instructor, two pilots and deicing crew on hand at 10:30. The aircraft was taxied to the Air Canada deicing centre and parked leading edge into the wind.

Two tall ladders were used to reach the wing. Speed tape was used to mark measurement locations on the wing. This aircraft has a rubber deicing boot which has slight ridges making it impossible to measure thickness over the boot. Leading edge fluid thickness measuring positions were relocated to an area with a continuous metal surface.

A single plate test was run; the wind kept the fluid on the upper portion of the plate resulting in unusually high thickness readings.

Markings put on with grease pencil ran when fluid was applied, and were replaced with tape and a marking pen.

Two aircraft tests were run; one without and one with propeller running. The propeller was run for five minutes.

In test with propeller running, it could be seen that fluid was blowing off in propeller wash; fluid thickness measurements on top of wing behind the propeller showed the wing was still wet although measurements were very thin; more fluid remained at the rear of the wing on the control surface area.

APPENDIX G - NARRATIVE REPORTS ON AIRCRAFT TESTS - 1996/97 WINTER

Overnight Test - February 4/5, 1997

American Airlines Fokker 100

Tests were planned with an American Airlines Fokker 100 aircraft with tests to be conducted at the back of the ramp area off Gate 16.

Snowfall was forecast for the full overnight period to noon the following day, and proved to be the case.

The test site was set up with equipment prior to the aircraft becoming available. Ladders were brought from the Air Canada site, and the two mast lights with support equipment were assembled. Two vans were used for moving equipment which sped up the process. During the test, one van was used for the lab (meteo), and the other as a shelter for the team members.

The site was cleared of snow by Aéroports de Montréal at about 00:30.

The aircraft arrived at 00:03 and was towed to the pad at 00:50, and parked tail into wind.

Set up of aircraft and equipment for the test went quickly.

Guest observers included two researchers from Université du Québec à Chicoutimi (UQAC) and one from AlliedSignal. A representative from the National Research Council was present taking wind measurements during the entire test duration at the request of the Transportation Development Centre. The Transport Canada team were not present.

The light on the port wing became unserviceable early in the test when the ballast burned out, and a spare had not been provided. Standard illumination as used in tests in previous years were employed (attached to ladders). This provided a minimum of light, and this wing was used for Type IV tests.

Fluid was applied by AMR. First application of Type IV was very rushed and inconsistent. The second wing was somewhat improved but still short of full coverage.

At test end, Hudson General cleaned up the glycol that had pooled; snow with glycol was left for the snow removal crew. Hudson General were difficult to contact.

APPENDIX G - NARRATIVE REPORTS ON AIRCRAFT TESTS - 1996/97 WINTER

Test - February 7, 1997

Inter-Canadian ATR 42, Test # 2

Weather - wind about 15 kph; temperature -3°C; partly cloudy and then clear

The aircraft was towed to the Air Canada deicing pad at 10:00 and positioned with the nose into the wind.

Fluid thickness measurement locations were marked on the wing. These positions differed slightly from the initial plan because of the rubber deicing boots. The *P* locations were placed at the high point on the chord. This was close to the leading edge. To get a better understanding of propeller wash, additional *P* points were placed on the wing aft of the propeller.

Tests on this day were with Type IV fluid, and tests on February 4, 1997 were with Type I fluid. The Type IV fluid was applied over Type I XL54 fluid. Two tests were conducted on February 7, 1997. For each test, measurements were taken after application. Measurements of film thickness were taken again following a five-minute period with the propeller running.

Results similar to the Type I fluid tests were observed.

Overnight Test - February 20/21, 1997

Tests were planned with American Airlines, however they were unable to cooperate. As a result, tests were performed on a Canadian Airlines International Boeing 737 aircraft at the Air Canada deicing centre.

Thickness tests were started, but at about 1:45 freezing rain started and the tests became full-scale tests. Five tests were run before the freezing rain turned to rain at about 4:00 (three Type I, two Type IV).

Intense freezing rain was encountered during the two hours of testing. Rates as high as 30 g/dm²/hr were recorded.

Note that this was the best Type IV application observed to date.

Note also that the RVSI unit stopped functioning soon after arrival at the airport.

APPENDIX G - NARRATIVE REPORTS ON AIRCRAFT TESTS - 1996/97 WINTER

Test - February 26, 1997

A Turboprop test was planned with Inter-Canadian but was cancelled since there was no precipitation.

Costs were incurred for a truck rental, airport escort, and preparation time.

Test - February 27, 1997

A Turboprop test was planned with Inter-Canadian but was cancelled since the expected cold front moved in late and the precipitation was rain.

Costs were incurred for a truck rental, airport escort, and preparation time.

Test - March 4, 1997

A Turboprop test was planned with Inter-Canadian but cancelled because precipitation started at 13:00, five hours later than expected.

Overnight Test - March 6, 1997

Tests were planned with American Airlines on a Fokker 100 aircraft. 75 gallons of Type IV fluid were obtained from Air Canada since American Airlines had run out and could not get more on time. The Transportation Development Centre was also present for the occasion.

Snow and blowing snow conditions starting at 12:00 and continued for the entire evening. The storm brought 15-20 cm of snow in total. 5 cm of snow was forecast.

The aircraft was delivered between 1:00 and 1:30. The application of fluid to the aircraft was better than other occasions but still was not at the level of quality desired. At about 3:00 the plane was shifted into a crosswind position.

It should be noted that the RVSI unit was not available since it still had not been repaired from when it broke down on February 21, 1997. This was due to delayed action on the part of RVSI.

APPENDIX G - NARRATIVE REPORTS ON AIRCRAFT TESTS - 1996/97 WINTER

DeHavilland Dash 8 Tests: DND Winnipeg, March 8, 1997

These tests were planned with a Dash 8 aircraft at the Military Base at the Winnipeg airport.

Weather forecasts issued on Friday March 7 indicated that light snow, up to 2 cm could be expected on March 8. Time of snow was unclear with one source indicating possibility of early morning snow and another indicating snow in the afternoon. It was decided to send the test crew on Friday evening to take advantage of morning snow if it occurred. The Department of National Defence was advised, as well as a local manpower office where arrangements were made for three personnel to serve as assistants. The contracted photographer was also advised.

Saturday morning, the local weather office still indicated some possibility of snow in the morning, along with winds. The test crew proceeded to the Base for 8:00 at which time a trace of snow pellets could be seen. This snow stopped by 8:15. One member remained at the hotel to meet the local staff and to brief them.

Sergent Whelan met the test crew and arranged to have the aircraft positioned nose into the wind, and to place two tests stands. A pick-up truck was made available for the meteo scale. The truck also served as a warm-up shelter between runs.

As there was no snow it was decided to perform thickness tests and both wings of the aircraft were marked. The wing shape was considerably different from the ATR 42, with the high point of the chord well back on the wing. Measurement gauges with extensions would have been useful for these points. The portable flat plate stand was set up using the truck spare tire as a stabilizing weight which worked very well. The wing temperature was measured, showing upper skin temperature of 0 to -6°C. The aircraft had been parked in the hangar overnight, and only moved out in the morning, despite the plan to cold-soak it.

The local personnel arrived at the base about 10:15. Only two of the planned three staff showed up, sufficient for the thickness tests. These two were not adequately dressed for the exercise and needed considerable warm-up recovery time. The photographer appeared to perform well enough and took direction willingly.

Discussions with the pilot, Captain King, concluded that he would be able to run the propeller with engine and propeller settings giving a strong propeller wash over the wing, and avoiding the need to taxi the aircraft. Fuel was boarded to enable the ground run (about 2 500 lbs in the main tank and 250 in each wing). Pre-flight checks performed by the pilot are extensive and take about 20 minutes before the engine can be started. These were performed during the initial fluid test.

APPENDIX G - NARRATIVE REPORTS ON AIRCRAFT TESTS - 1996/97 WINTER

Fluid thickness tests performed included;

- Nose into wind, without propellers;
- Nose into wind, with propeller running; and
- Crosswind with propeller running (one wing then the other).

Flat plate tests were performed using Military Type I and Union Carbide XL54 Type I.

The wind at start of test had shifted and strengthened and the aircraft was repositioned into the wind. Wind strength was between 16 to 36 knots averaging 24 knots (30 to 67 kph average 45 kph). Temperature at start was -6°C.

When the first test was initiated it was found that the fluid in the truck was cold, and a delay was encountered while it was heated.

During the tests, it was seen that the fluid run off the wing very quickly, leaving very little to measure and giving an appearance of fluid on a waxed surface where drops of fluid form. When this was discussed with local staff, they reported that they use a water repellent fluid *Ice EX* on the leading edge, and that this fluid may have migrated back over the main wing. The only difference for the area in the propeller wash was that the drops of fluid were even smaller than elsewhere. The nose of the leading edge showed film thickness.

Dr. Norman Ellis of DeHavilland Toronto arrived about 14:00, having been invited by the Transportation Development Centre. He observed the last of the crosswind fluid thickness trials.

No snow fell, the sun came out about 14:00, and no snow was forecast. Tests terminated following the thickness tests.

As the Transportation Development Centre indicated that a second test event might be conducted if a positive forecast of a good snowfall occurred, some equipment was left with the Department of National Defence at Winnipeg. As well, the Transportation Development Centre discussed with the Department of National Defence the possibility of flying the aircraft to Dorval for tests.

All the Military staff at Winnipeg were very cooperative, and Sergeant Larry Whelan who served as our contact was most helpful.

APPENDIX G - NARRATIVE REPORTS ON AIRCRAFT TESTS - 1996/97 WINTER

Turboprop Test, March 14, 1997

A Turboprop test was planned on an Inter-Canadian ATR 42. The Transportation Development Centre was also present for the test.

There was snow and blowing snow conditions starting at approximately 11:00. The tests did not start until approximately 11:30 due to the fact that the plane needed to be taxied out to the test location.

Failure occurred first in the propeller wash area on the wing. While the plane was positioned with the nose into the wind, the wing failed along the leading edge and trailing edge. The centre of the wing did not fail before the plane was turned into a crosswind position. This could partly be due to the aerodynamics of the wing. Once the plane was in the crosswind position, the fluid failed very quickly. This was probably mostly due to the increased rates of precipitation but may also be partly attributed of the swirling of snow over the wing due to the crosswind orientation of the plane. Both wings failed in approximately the same amount of time.

A minimum of two stairs are needed per wing to avoid conflicting interests between samples, camera and contours.